



INSTRUCTIONS

J03436

2013-11-01



CHROME AUXILIARY LAMP KIT

GENERAL

Kit Number

69284-05

Models

For model fitment information, see the P&A retail catalog or the Parts and Accessories section of www.harley-davidson.com (English only).

NOTE

Auxiliary / fog lamps are not included in this kit. The desired style of lamp must be purchased separately. HDI (International) motorcycles should only use approved fog lamps.

Kit Contents

See Figure 11 and Table 1.

Models with turn signals mounted on the upper or lower triple clamp will also require Front Directional Relocation Kit (Part No. 68603-01), available separately at your Harley-Davidson Dealer.

NOTICE

It is possible to overload the vehicle's charging system by adding too many electrical accessories. If the combined electrical accessories operating at any one time consume more electrical current than the vehicle's charging system can produce, the electrical consumption can discharge the battery and cause damage to the vehicle's electrical system. (00211d)

NOTE

These lamps require 2.9 amps of available current from the motorcycle's electrical system.

⚠ WARNING

Rider and passenger safety depend upon the correct installation of this kit. Use the appropriate service manual procedures. If the procedure is not within your capabilities or you do not have the correct tools, have a Harley-Davidson dealer perform the installation. Improper installation of this kit could result in death or serious injury. (00333b)

NOTE

This instruction sheet references Service Manual information. A Service Manual for your model motorcycle is required for this installation and is available from a Harley-Davidson Dealer.

INSTALLATION

⚠ WARNING

To prevent accidental vehicle start-up, which could cause death or serious injury, disconnect negative (-) battery cable before proceeding. (00048a)

⚠ WARNING

Disconnect negative (-) battery cable first. If positive (+) cable should contact ground with negative (-) cable connected, the resulting sparks can cause a battery explosion, which could result in death or serious injury. (00049a)

1. See the Service Manual. Remove the seat and disconnect the battery cables, negative cable first.

⚠ WARNING

Stop the engine when refueling or servicing the fuel system. Do not smoke or allow open flame or sparks near gasoline. Gasoline is extremely flammable and highly explosive, which could result in death or serious injury. (00002a)

2. See the Service Manual. Remove the fuel tank.
3. See Figure 1. The mounting brackets (1) and clamps (2) are side-specific. Select the right-hand or left-hand bracket and clamp, and install on the fork tube using two button-head screws (3) from the kit.

NOTE

Tighten the outer screw first.



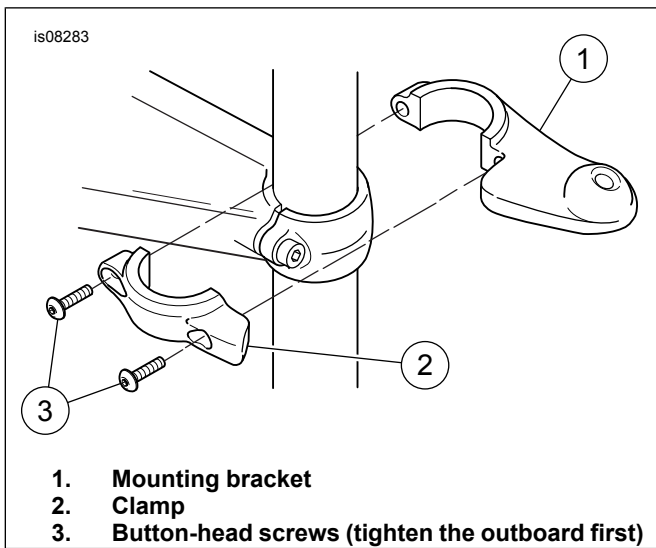

Figure 1. Install the Mounting Bracket on the Fork Tube (Right-Hand Side Shown)

4. Tighten the screws to 70-80 in-lbs (8-9 Nm).
5. See Figure 2. Route the lamp wire (1) through the hole in the mounting bracket (2), and secure the lamp (3) to the bracket using a clamp block (4), lockwasher (5) and retainer (6) from the kit. Tighten the retainer to 16-18 ft-lbs (22-24 Nm).
6. See Figure 11. Locate the outer trim ring (24), inner nesting ring (27), screw (25), and nut (26).
7. See Figure 3. Place the inner nesting ring on the bulb. Connect the black wire to the bulb spade terminal next to the bulb indexing tab (1) on the bulb. Install the gray wire on the remaining spade terminal.
8. Attached the bulb and nesting ring using the trim ring, screw and nut identified in step 6.
9. Slide the conduit (7) from the kit over the lamp wire.
10. Repeat Steps 3 through 9 for the opposite side.

NOTE

See Figure 4 for wiring harness component identification.

NOTICE

When routing wires and harnesses, verify that they are clear of moving parts, heat sources and pinch points to avoid wire damage or a short circuit, which could result in electrical system damage. (00579b)

11. See Figure 5. Install the wiring harness. Place the relay (1) in the opening in the seat pan, and route the long leg of the harness (3) along the frame backbone. **2004 and later XL models:** See Figure 6. Remove the nuts retaining the ignition module (1) and temporarily reposition the module as shown. Place the relay in the recessed area (2) of the oil reservoir. Install the ignition module. Route the long leg of the harness along the frame backbone. **All 2003 and earlier models:** See Figure 4. Cut the connector from the white power lead, and replace it with the ring terminal supplied in the kit. Connect the white wire with the ring terminal to the copper stud (BAT) terminal of the main circuit breaker. **All 2004 and later models:** Connect the white wire with connector to the B+ connector on the motorcycle's harness.

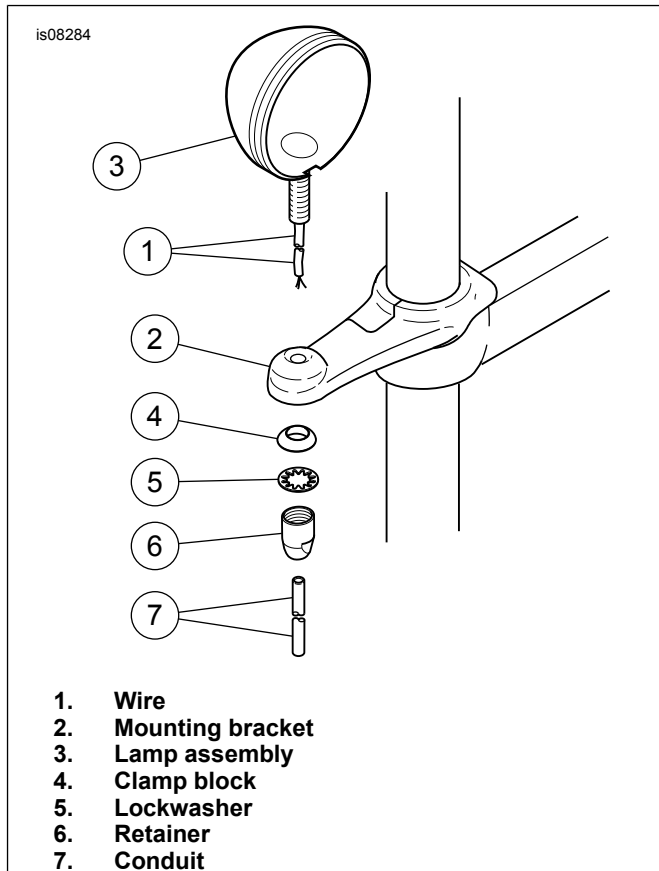

Figure 2. Install the Lamps (Right-Hand Side Shown)

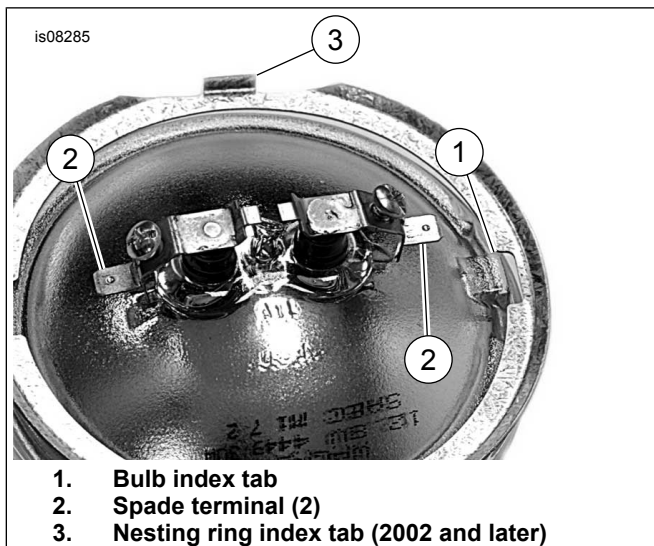

Figure 3. Auxiliary Lamp Bulb Terminals

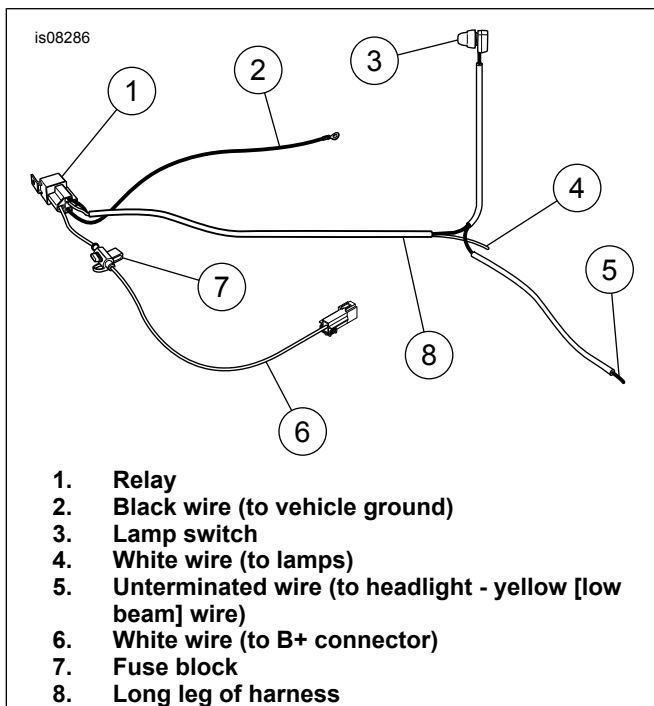

Figure 4. Wiring Harness Component Identification

12. See Figure 4. Connect the black ground wire (2) with the ring terminal to the ground stud under the seat, or at any good electrical ground point. Secure the kit harness to the adjacent harnesses with cable straps (Item 16) from the kit.

NOTICE

When routing wires and harnesses, verify that they are clear of moving parts, heat sources and pinch points to avoid wire damage or a short circuit, which could result in electrical system damage. (00579b)

13. See Figure 4. Route the harness past the steering head, and route the lamp switch (3) leg of the harness along the left side of the handlebar to the clutch control.

14. See Figure 11. Obtain the switch mounting bracket (Item 19) from the kit. Unscrew the boot from the lamp switch, and install the switch into the bracket. Replace the boot on the switch.

NOTE

If the boot becomes worn or damaged, or is lost, replace the boot to prevent moisture from entering the switch. See the Service Parts illustration (Item 11).

15. See Figure 7. Remove the lower screw (1) and washer from the clutch control clamp, and install the lamp switch and bracket assembly (2). Install the screw and washer and tighten to 60-80 in-lbs (7-9 Nm). **For International Applications:** Place the fog lamp switch label (3) on the clutch control clamp.

16. See Figure 11. Secure the lamp switch leg of the harness to the handlebar using the wire harness retainers (Item 18) as needed. Snap the retainers into the holes in the handlebar.

17. See the Service Manual. Remove the headlamp assembly.

NOTE

When wired as follows, the auxiliary lamps can only be operated while the main headlamp is on low beam. This conforms to many state and local laws.

18. See Figure 8. Route the unterminated wire (1) from the switch through the grommet into the headlight housing. Splice it to the yellow (low beam) wire (2) using the Scotchlok® electrical connector (Item 14) from the kit.

NOTE

To route the wire through the grommet, push a hooked piece of wire through the grommet from the inside of the headlamp housing. Soap the toggle switch wire and pull it back through the grommet with the hooked wire.

In some applications the wire from the kit harness may not fit through the headlight housing grommet. If this is the case, splice the black wire to the yellow wire outside the headlight housing, then tape the connector to shield it from moisture.

19. See the Service Manual. Install the headlamp assembly.

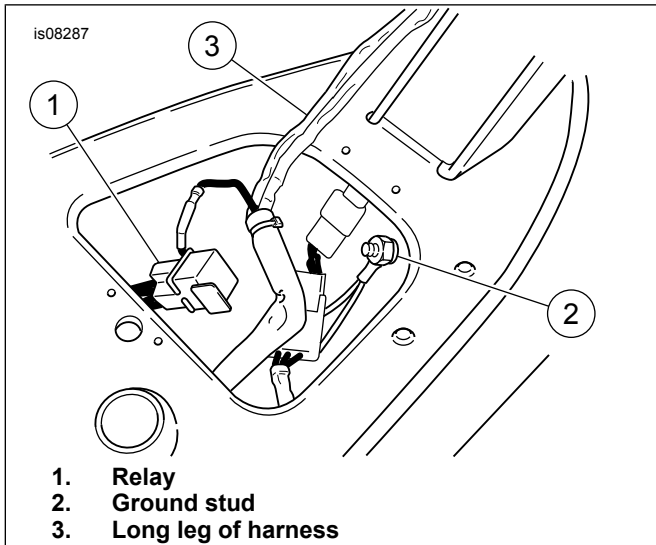

Figure 5. Install the Wiring Harness (Dyna Model Shown)

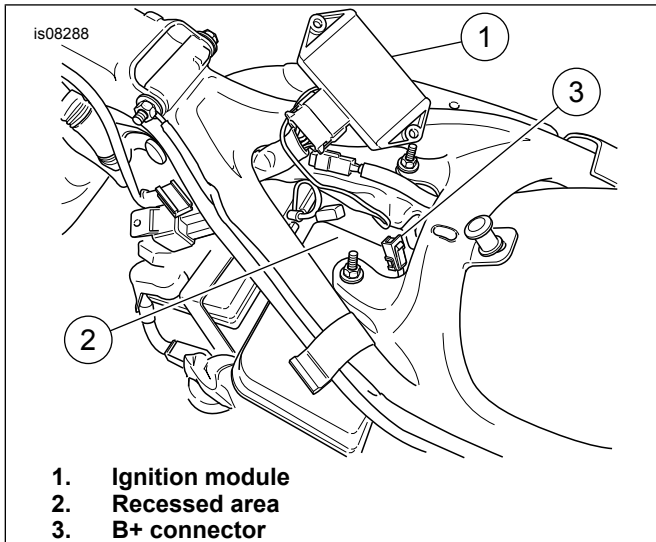

Figure 6. Install the Wiring Harness (2004 and Later Models)

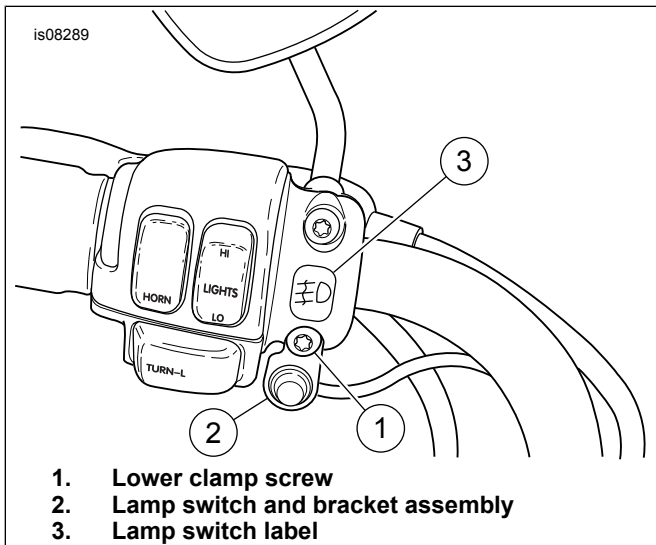

Figure 7. Install the Lamp Switch on the Clutch Control Clamp (1996 and Later Shown)

20. See Figure 9 and Service Manual. Slide the heat-shrink tubing (1) over the white wire (2) from the kit harness, and crimp the electrical connector (3) to the wire with a Crimp Tool (H-D 38125-8).

21. Bring both lamp wires (4) to the connector. Trim the wires, allowing approximately 1 inch (25 mm) of the wire to extend past the butt splice connector. Trim the conduit (5) approximately 1-1/2 in. (38 mm) back from the end of the wire.

22. Remove approximately 3/8 in. (10 mm) of insulation from the end of the lamp wires.

23. Insert the ends of both lamp wires (4) into the electrical connector (3) and crimp the wires to the connector with the crimp tool.

NOTE

Avoid directing heat toward any fuel system component.

Extreme heat can cause fuel ignition/explosion resulting in death or serious injury.

Avoid directing heat toward any electrical system component other than the connectors on which heat shrink work is being performed.

Always keep hands away from tool tip area and heat shrink attachment

NOTE

Protect the heat-shrink tubing from the heat source while applying heat to the electrical connector.

▲ WARNING

Be sure to follow manufacturer's instructions when using the UltraTorch UT-100 or any other radiant heating device. Failure to follow manufacturer's instructions can cause a fire, which could result in death or serious injury. (00335a)

24. Slide the heat-shrink tubing (1) away from the splice and using the UltraTorch UT-100 (H-D 39969), Robinair Heat Gun (H-D 25070) with Heatshrink Attachment (H-D 41183), or other suitable radiant heating device, heat the crimped splice to encapsulate the butt splice connection. Apply heat from the center of the crimp out to each end until the meltable sealant exudes out of both ends of the connector. Let the connector cool.

25. Slide the heat-shrink tubing back over the splice and using the same radiant heating device, heat the tubing to encapsulate the butt splice connection. Apply heat from the center of the tubing out to each end.

NOTICE

When routing wires and harnesses, verify that they are clear of moving parts, heat sources and pinch points to avoid wire damage or a short circuit, which could result in electrical system damage. (00579b)

26. Secure the wires to the lower fork steering bracket using the adhesive backed clips (Item 15) from the kit.

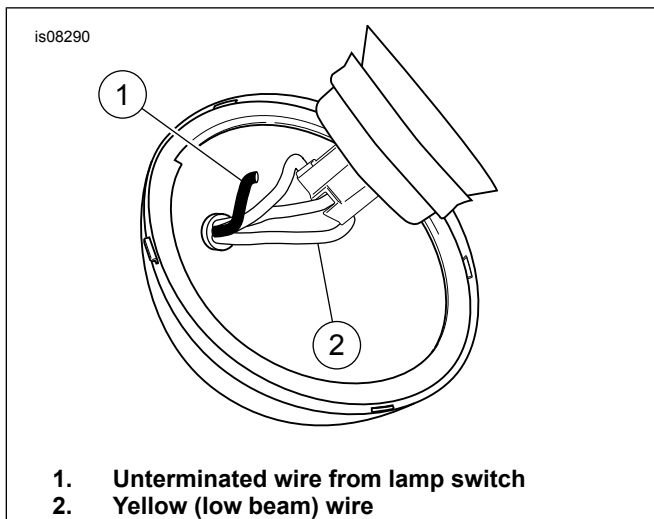

Figure 8. Splice the Unterminated Wire from the Switch to the Headlight Yellow (Low Beam) Wire

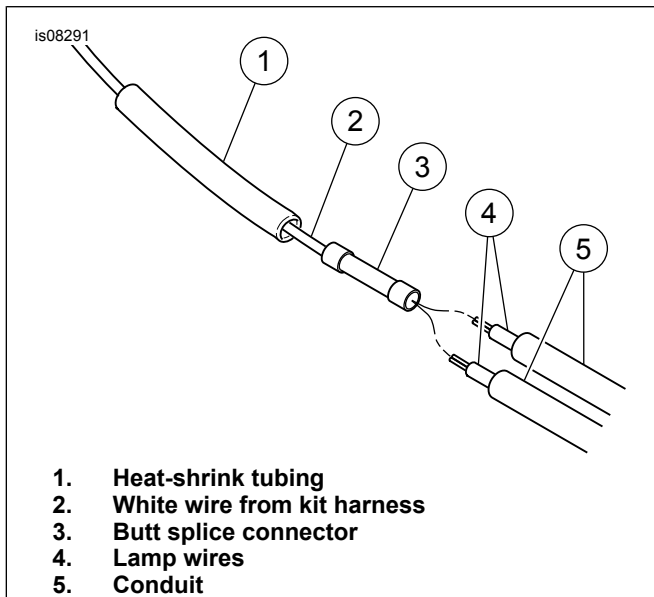

Figure 9. Connect the Lamp Wires to the Kit Harness

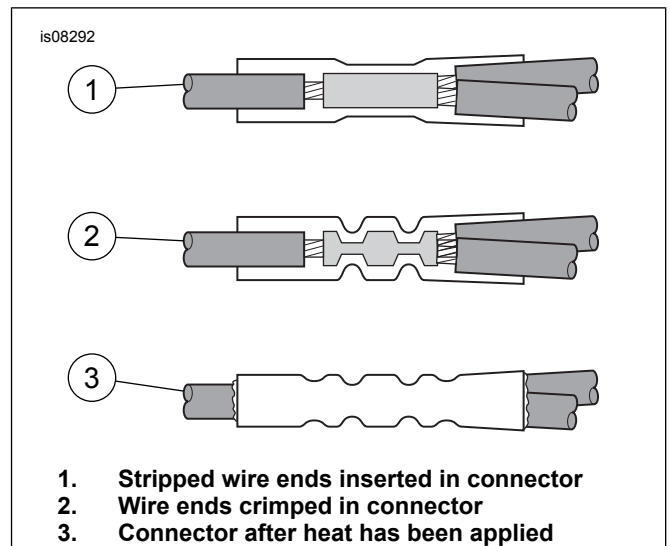

Figure 10. Installing Sealed Butt Splice Connectors

⚠ WARNING

Stop the engine when refueling or servicing the fuel system. Do not smoke or allow open flame or sparks near gasoline. Gasoline is extremely flammable and highly explosive, which could result in death or serious injury. (00002a)

27. See the Service Manual. Install the fuel tank.

⚠ WARNING

Connect positive (+) battery cable first. If positive (+) cable should contact ground with negative (-) cable connected, the resulting sparks can cause a battery explosion, which could result in death or serious injury. (00068a)

28. Connect the battery cables, positive cable first.

⚠ WARNING

After installing seat, pull upward on seat to be sure it is locked in position. While riding, a loose seat can shift causing loss of control, which could result in death or serious injury. (00070b)

29. See the Service Manual. Install the seat.

⚠ WARNING

Be sure headlamp, tail and stop lamp and turn signals are operating properly before riding. Poor visibility of rider to other motorists can result in death or serious injury. (00478b)

30. Test headlamp high and low beams, and the auxiliary lamps for proper operation. Aim the auxiliary lamps and tighten the lamp mounting nuts.

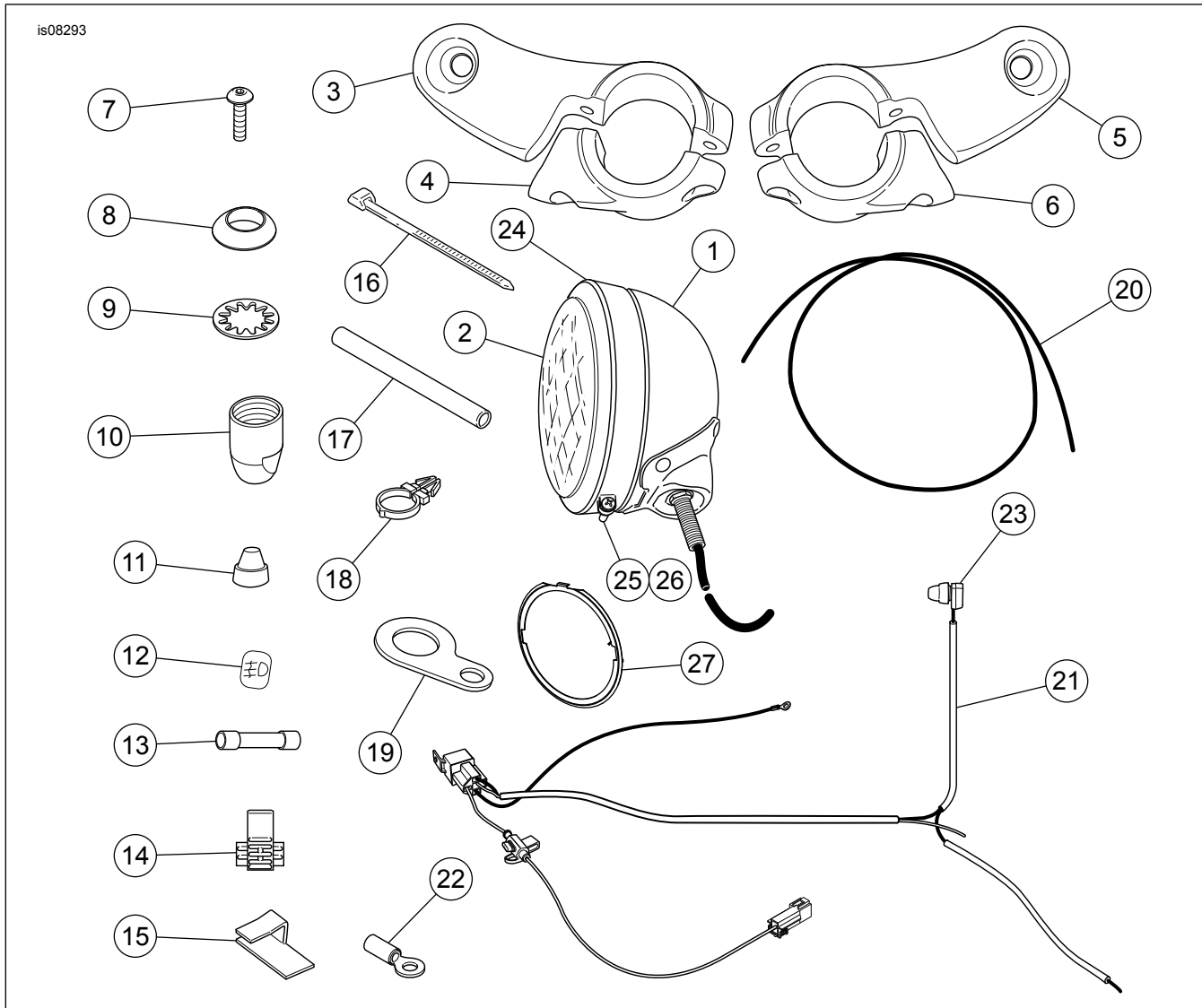

Figure 11. Service Parts

Table 1. Service Parts

Item	Description (Quantity)	Part Number
1	Passing lamp housing (2)	68276-02
2	Sealed unit (purchased separately)	reference only
3	Bracket, lamp mounting (right)	Not sold
4	Clamp, lamp mounting (right)	Not sold
5	Bracket, lamp mounting (left)	Not sold
6	Clamp, lamp mounting (left)	Not sold
7	Screw, socket head, 1/4-20 x 3/4 in., locking (4)	927A
8	Clamp block, auxiliary lamp (2)	68720-62
9	Lockwasher, internal tooth, 3/8 in. (2)	7130W
10	Retainer, lamp mounting (2)	Not sold
11	Boot, switch	67880-94
12	Label, lamp switch, HDI (international only)	68604-01
13	Connector, pre-insulated, sealed, butt splice	70586-93
14	Connector, electrical (Scotchlok®, blue)	70576-68
15	Clip, adhesive-backed (4)	10102
16	Cable strap, 7.8 in. (19.8 cm) (12)	10181
17	Shrink tube	72266-94
18	Harness retainer (4)	70345-84
19	Bracket, switch mounting	Not sold
20	Conduit, vinyl, 15 in. (38.1 cm) (2)	Not sold
21	Wiring harness assembly	Not sold

Table 1. Service Parts

Item	Description (Quantity)	Part Number
22	Ring terminal	9858
23	Switch	70370-00
24	Trim ring	68725-62A
25	Screw	3514
26	Nut	7606
27	Inner nesting ring	68331-02