



INSTRUCTIONS

J02069

2013-11-01



DIRECTIONAL RELOCATION KIT FOR MODELS WITH PASSING LAMPS

GENERAL

Kit Number

68603-01

Models

For model fitment information, see the P&A retail catalog or the Parts and Accessories section of www.harley-davidson.com (English only).

NOTE

This instruction sheet references Service Manual information. A Service Manual for your model motorcycle is required for this installation and is available from a Harley-Davidson Dealer.

Kit Contents

See Figure 15 and Table 1.

⚠ WARNING

Rider and passenger safety depend upon the correct installation of this kit. Use the appropriate service manual procedures. If the procedure is not within your capabilities or you do not have the correct tools, have a Harley-Davidson dealer perform the installation. Improper installation of this kit could result in death or serious injury. (00333b)

INSTALLATION

⚠ WARNING

To prevent accidental vehicle start-up, which could cause death or serious injury, disconnect battery cables (negative (-) cable first) before proceeding. (00307a)

⚠ WARNING

Disconnect negative (-) battery cable first. If positive (+) cable should contact ground with negative (-) cable connected, the resulting sparks can cause a battery explosion, which could result in death or serious injury. (00049a)

1. Disconnect the negative battery cable.

2. On models in which the directional lights are mounted on the upper fork brackets, perform the following: On models in which the directional light is mounted to the mirror, perform the following:

- a. See Figure 1. Remove the fork tube pinch screw securing the right directional light assembly to the upper fork. Discard screw.
- b. Obtain a new pinch screw (part number 4351) from kit and install to upper fork bracket replacing screw removed in Step a. Tighten screw to 25-30 ft-lbs (33.9-40.7 Nm).
- c. Remove screw and lockwasher securing directional light to bracket. Discard screw, lockwasher and bracket.
- d. Repeat for the left side.
- e. Remove right directional light and discard all mounting hardware except internal toothed lockwasher.
- f. See Figure 2. Install acorn nut from kit to retain right mirror. If acorn nut "bottoms" without tightening, add the second spacer from kit in the location shown.
- g. Remove left directional light and discard hardware. Leave bracket which joined mirror and directional mount in place. Tighten mirror acorn nut, if necessary.

NOTE

On motorcycles with directional lights consisting of three wires, the third black wire is a ground wire. Check the style (either Standard or Bullet Style) of the directional lights and note how many wires are connected, then perform the Steps under one of the following applicable procedures.

- Relocating Standard Two-Wire Directionals.
- Relocating Standard Three-Wire Directionals.
- Relocating Bullet Style Three-Wire Directionals.



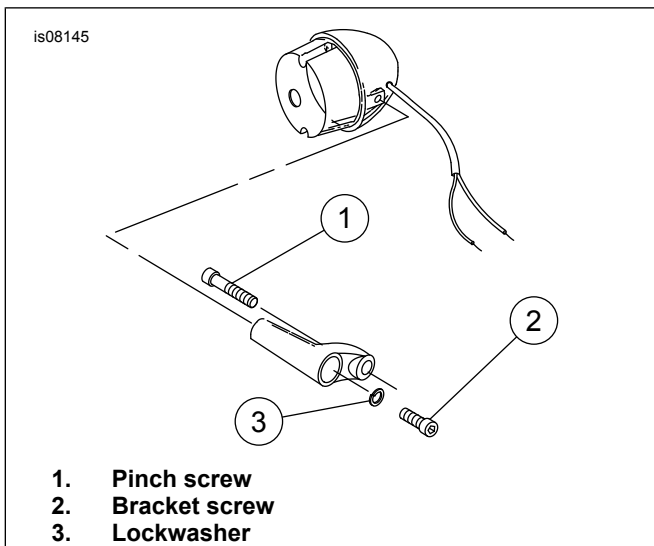

Figure 1. Directional Light Upper Fork Mounting

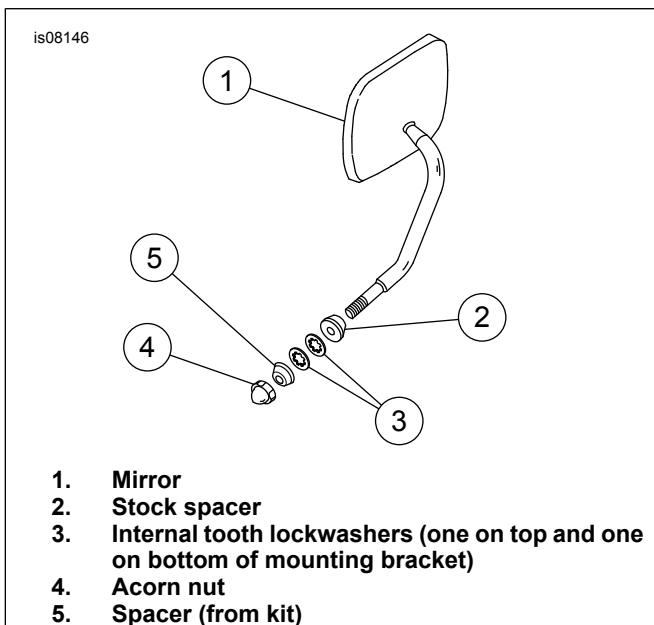

Figure 2. Installing Right Mirror

A. Relocating Standard Two-Wire Directionals:

NOTE

Before cutting wires at directional light, cut cable straps holding wires and determine if wires are long enough to reach bottom of passing lamp bracket. If wires are too short, perform Steps 1 through 10. If wire length is sufficient, proceed to Step 12.

1. Cut wires connected to right directional light about 2 in. (50.8 mm) away from directional light body.
2. Strip approximately 5/16 in. (9.5 mm) insulation from each of the wires.
3. Crimp butt-splice connectors from kit on two wires coming from motorcycle.
4. Split one end of the 2-conductor polarized wire from kit back about 2 in. (50.8 mm) and strip 5/16 in. (9.5 mm) of insulation from wire ends.

5. Slide a piece of shrink tubing from kit over each of the wire ends stripped in Step 4 and crimp the wires into the butt-splice connectors installed in Step 3. **Make sure you connect the silver and copper colored wires to like colored wires.**

NOTE

Polarized wire is used in this application to verify correct wiring. One wire is silver, one is copper colored. Wire colors of spliced wire must match wire color of original directional wire leads.

6. Cut polarized wires to the length required for connection to the wires at the relocated directional light. **Make certain you leave enough slack in wires to allow routing the harness along the fork tube.**
7. Split remaining end of the 2-conductor polarized wire from kit back about 2 in. (50.8 mm) and strip 5/16 in. (9.5 mm) of insulation from wire ends.
8. Slide a piece of heat shrink tubing over each of the two wire ends.
9. Connect like colored wires from jumper (polarized wires) to directional light wires using butt splice connectors from kit.

▲ WARNING

Be sure to follow manufacturer's instructions when using the UltraTorch UT-100 or any other radiant heating device. Failure to follow manufacturer's instructions can cause a fire, which could result in death or serious injury. (00335a)

- Avoid directing heat toward any fuel system component. Extreme heat can cause fuel ignition/explosion resulting in death or serious injury.
- Avoid directing heat toward any electrical system component other than the connectors on which heat shrink work is being performed.
- Always keep hands away from tool tip area and heat shrink attachment.

▲ WARNING

Be sure to follow manufacturer's instructions when using propane torches. Failure to follow manufacturer's instructions can cause a fire, which could result in death or serious injury. (00465c)

- Avoid directing heat toward any fuel system component.
 - Extreme heat can cause fuel ignition/explosion resulting in death or serious injury.
 - Avoid directing heat toward any electrical system component other than the connectors on which heat shrink work is being performed.
 - Always keep hands away from tool tip area and heat shrink attachment.
10. Slide heat shrink tubing over butt-splice connectors installed in steps 5 and 9. Activate shrink tubing with UltraTorch UT-100, heat gun or hair dryer, noting the following:
 11. Repeat steps 1 through 10 the opposite directional light.

12. If passing lamp kit is already installed and wired on the vehicle, cut the lead wire from the passing lamp kit at the handlebar clamp area as close to the joining butt splice as possible. Cut off the butt splice, as this will be replaced with a new splice from kit. Cut cable straps securing lead wire to fork tubes. See Figure 3. Remove retaining nut from passing lamp as shown and discard.

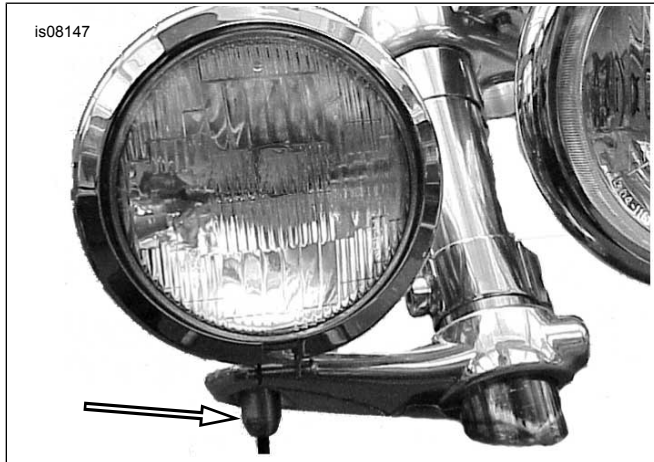
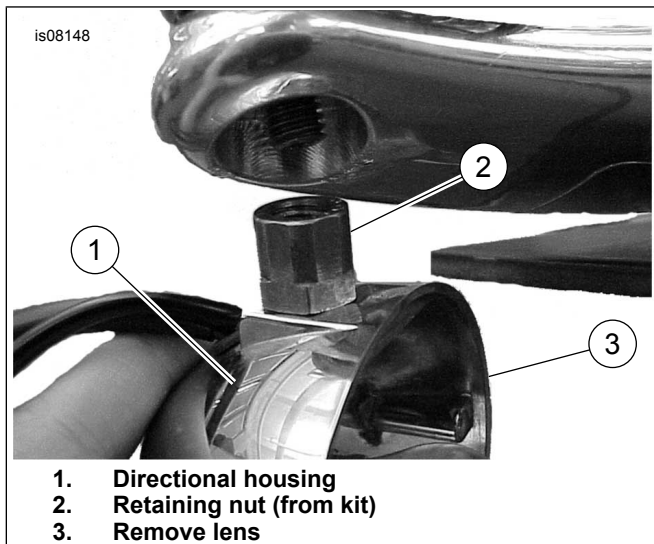

Figure 3. Remove Retaining Nut

13. See Figure 4. Install retaining nut (P/N 68323-01) from kit to directional housing and snug into place. Remove lens from directional housing.



1. Directional housing
2. Retaining nut (from kit)
3. Remove lens

Figure 4. Install Retaining Nut from Kit

14. See Figure 5. Route passing lamp lead wire through new retaining nut and into directional. Screw passing lamp onto directional. It may be necessary to loosen passing lamp bracket and pivot the lamp forward to allow clearance to rotate.

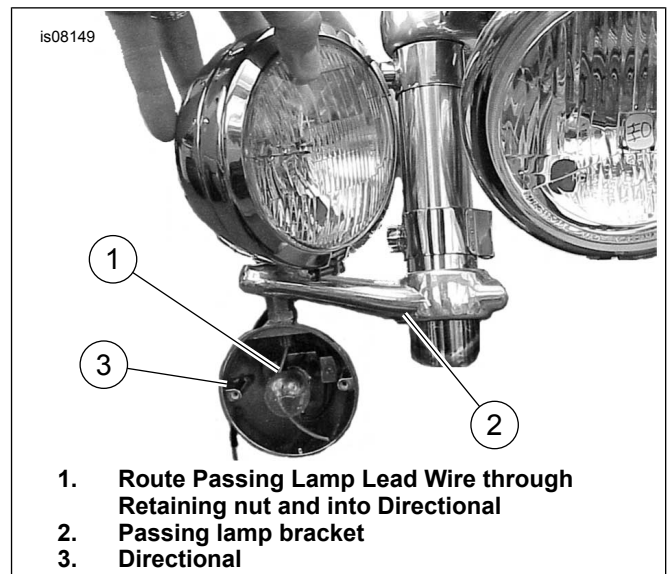

1. Route Passing Lamp Lead Wire through Retaining nut and into Directional
2. Passing lamp bracket
3. Directional

Figure 5. Install Passing Lamp To Directional

15. See Figure 6. Once directional is snug, back it off slightly to align the entire assembly. Install passing lamp wire through jam nut (P/N 7912) and snug nut into place.

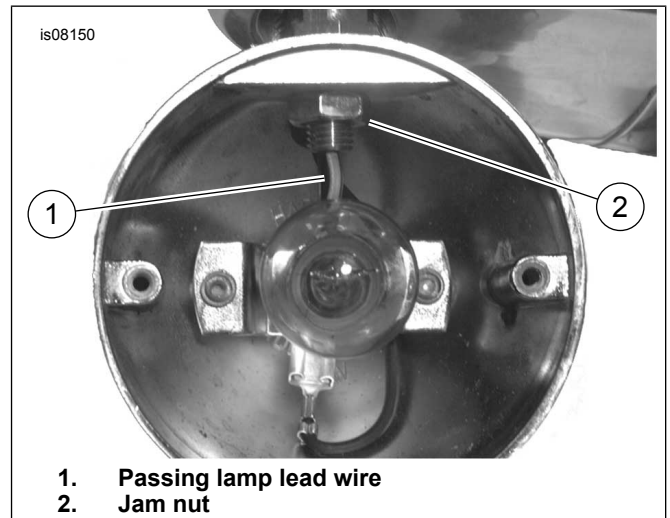

1. Passing lamp lead wire
2. Jam nut

Figure 6. Install Jam Nut

16. Continue to route passing lamp lead wire out through directional housing grommet (same path as directional wiring).

17. See Figure 7. Bring both passing lamp wires to the connector. Trim the wires, allowing approximately 1 in (25.4 mm) of wire to extend past the butt splice connector. Trim the conduit approximately 1-1/2 in (38.1 mm) back from the end of the wire.

18. Remove approximately 3/8 in (9.5 mm) of insulation from the end of the passing lamp wires.

19. Insert the ends of both passing lamp wires into the electrical connector and crimp the wires to the connector using a H-D 38125-8 Crimping Tool.

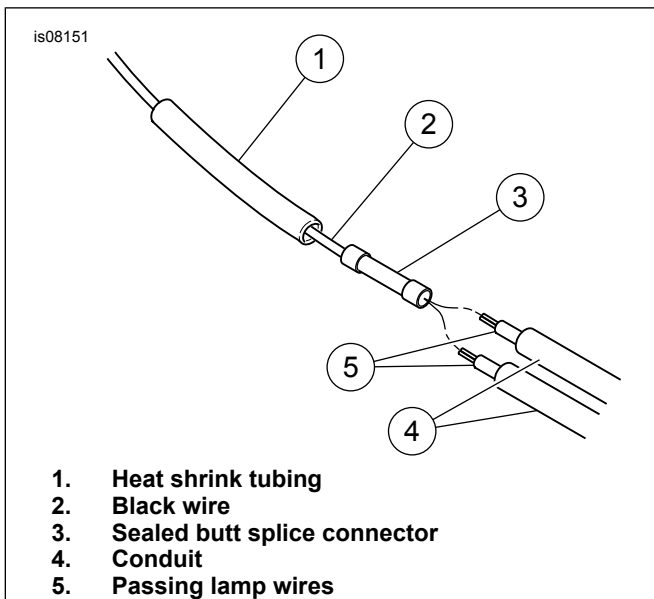

Figure 7. Connect Passing Lamp Wiring

⚠ WARNING

Be sure to follow manufacturer's instructions when using the UltraTorch UT-100 or any other radiant heating device. Failure to follow manufacturer's instructions can cause a fire, which could result in death or serious injury. (00335a)

- Avoid directing heat toward any fuel system component. Extreme heat can cause fuel ignition/explosion resulting in death or serious injury.
- Avoid directing heat toward any electrical system component other than the connectors on which heat shrink work is being performed.
- Always keep hands away from tool tip area and heat shrink attachment.

⚠ WARNING

Be sure to follow manufacturer's instructions when using the Robinair Heat Gun or any other radiant heating device. Failure to follow manufacturer's instructions can cause a fire, which could result in death or serious injury. (00379a)

- Avoid directing heat toward any fuel system component.
- Extreme heat can cause fuel ignition/explosion resulting in death or serious injury.
- Avoid directing heat toward any electrical system component other than the connectors on which heat shrink work is being performed.
- Always keep hands away from tool tip area and heat shrink attachment.

NOTE

Protect the heat shrink tubing from the heat source while applying heat to the electrical connector.

20. Slide the heat shrink tubing (1) away from the splice and using the UltraTorch UT-100 (H-D 39969), Robinair Heat Gun (H-D 25070) with Heatshrink Attachment (H-D 41183), or radiant heating device, heat the crimped butt splice connector. Apply heat from the center of the crimp out to each end until the meltable sealant exudes out of both ends of the connector. Let the connector cool.
21. Slide the heat shrink tubing over the splice and using the UltraTorch UT-100 (H-D 39969), Robinair Heat Gun (H-D 25070) with Heatshrink Attachment (H-D 41183), or radiant heating device, heat the heat shrink tubing to encapsulate the butt splice connection. Apply heat from the center of the crimp out to each end.

NOTICE

When routing wires and harnesses, verify that they are clear of moving parts, heat sources and pinch points to avoid wire damage or a short circuit, which could result in electrical system damage. (00579b)

22. Position harness along fork tube and secure with cable straps.
23. Test operation of directional lights and running lights. If operation is not correct, verify that the wire splices were made properly.
24. Align entire assembly and tighten all mounting hardware. Replace lens onto directional housing using Loctite 243 (blue).

B. Relocating Standard Three-Wire Directionals:

NOTE

Before cutting wires at directional light, cut cable straps holding wires and determine if wires are long enough to reach bottom of passing lamp bracket. If wires are too short perform Steps 1 through 14. If wire length is sufficient, proceed to Step 16.

1. Carefully cut 4 in. (101.6 mm) from conduit covering the wires connected to right directional light.
2. Cut the directional light wires at the following lengths from the directional light:
 - a. Blue wire- 1-1/4 in. (31.7 mm) from directional light
 - b. Violet wire- 2-1/4 in. (57.7 mm) from directional light
 - c. Black wire- 3-1/4 in. (82.5 mm) from directional light

NOTE

The wires are cut at different lengths to stagger the butt connectors and prevent a large bulge in the harness.

3. Strip 5/16 in. (9.5 mm) of insulation from the cut ends of the three wires cut in Step 2.
4. Crimp butt-splice connectors from kit on three wires coming from motorcycle.
5. Cut a 6 in. (152.4 mm) length of wire from the black, blue and violet wires in the kit.

6. Strip 5/16 in. (9.5 mm) of insulation from one end on each of the jumper wires then connect like colored wires and crimp into butt-splice connectors (from motorcycle) installed in step 4.
7. Slide shrink tubing from kit over crimped terminals. Activate shrink tubing with heat gun or hair dryer.
8. Cut an appropriate length of 5/16 in. (9.5 mm) ID vinyl tubing supplied with kit.
9. Slide appropriate length section of tubing onto three wires connected in Step 6 and over existing conduit.
10. Cut the three spliced-on wires to lengths required for connection to wires coming from the directional light. Make certain to leave enough slack to allow routing harness along fork tube.
11. Slide heat shrink tubes over the three wire ends.
12. Strip 5/16 in. (9.5 mm) of insulation from remaining wire ends and connect like colored wires at directional light with butt-splice connectors from kit.
13. Activate shrink tubing with UltraTorch UT-100, heat gun or hair dryer noting the following:

▲ WARNING

Be sure to follow manufacturer's instructions when using the UltraTorch UT-100 or any other radiant heating device. Failure to follow manufacturer's instructions can cause a fire, which could result in death or serious injury. (00335a)

- **Avoid directing heat toward any fuel system component. Extreme heat can cause fuel ignition/explosion resulting in death or serious injury.**
- **Avoid directing heat toward any electrical system component other than the connectors on which heat shrink work is being performed.**
- **Always keep hands away from tool tip area and heat shrink attachment.**

▲ WARNING

Be sure to follow manufacturer's instructions when using the Robinair Heat Gun or any other radiant heating device. Failure to follow manufacturer's instructions can cause a fire, which could result in death or serious injury. (00379a)

- **Avoid directing heat toward any fuel system component.**
- **Extreme heat can cause fuel ignition/explosion resulting in death or serious injury.**
- **Avoid directing heat toward any electrical system component other than the connectors on which heat shrink work is being performed.**
- **Always keep hands away from tool tip area and heat shrink attachment.**

14. Slide the 5/16 in. (9.5 mm) vinyl tubing, installed in Step 9, over all new connections.
15. Repeat Steps 1 through 14 for opposite directional light.

16. If passing lamp kit is already installed and wired on the vehicle, cut the lead wire from the passing lamp kit at the handlebar clamp area as close to the joining butt splice as possible. Cut off the butt splice, as this will be replaced with a new splice from kit. Cut tie straps securing lead wire to fork tubes. See Figure 3. Remove retaining nut from passing lamp as shown and discard.
17. See Figure 4. Install retaining nut (P/N 68323-01) from kit to directional housing and snug into place. Remove lens from directional housing.
18. See Figure 5. Route passing lamp lead wire through new retaining nut and into directional. Screw passing lamp onto directional. It may be necessary to loosen passing lamp bracket and pivot the lamp forward to allow clearance to rotate.
19. See Figure 6. Once directional is snug, back it off slightly to align the entire assembly. Install passing lamp wire through jam nut (P/N 7912) and snug nut into place.
20. Continue to route passing lamp lead wire out through directional housing grommet (same path as directional wiring).
21. Install a cable strap to secure passing lamp lead wire to 5/16 in. (9.5mm) directional wire conduit.
22. Refer to Figure 7. Bring both passing lamp wires to the connector. Trim the wires, allowing approximately 1 inch (25.4 mm) of wire to extend past the sealed butt connector. Trim the conduit approximately 1-1/2 in. (38.1 mm) back from the end of the wire.
23. Remove approximately 3/8 inch (9.5 mm) of insulation from the end of the passing lamp wires.
24. Insert the ends of both passing lamp wires into the electrical connector and crimp the wires to the connector using a H-D 38125-8 Crimping Tool.

▲ WARNING

Be sure to follow manufacturer's instructions when using the UltraTorch UT-100 or any other radiant heating device. Failure to follow manufacturer's instructions can cause a fire, which could result in death or serious injury. (00335a)

- **Avoid directing heat toward any fuel system component. Extreme heat can cause fuel ignition/explosion resulting in death or serious injury.**
- **Avoid directing heat toward any electrical system component other than the connectors on which heat shrink work is being performed.**
- **Always keep hands away from tool tip area and heat shrink attachment.**

▲ WARNING

Be sure to follow manufacturer's instructions when using propane torches. Failure to follow manufacturer's instructions can cause a fire, which could result in death or serious injury. (00465c)

- **Avoid directing heat toward any fuel system component.**
- **Extreme heat can cause fuel ignition/explosion resulting in death or serious injury.**
- **Avoid directing heat toward any electrical system component other than the connectors on which heat shrink work is being performed.**

- **Always keep hands away from tool tip area and heat shrink attachment.**

NOTE

Protect the heat shrink tubing from the heat source while applying heat to the electrical connector.

25. Slide the heat shrink tubing (1) away from the splice and using the UltraTorch UT-100 (H-D 39969), Robinair Heat Gun (H-D 25070) with Heatshrink Attachment (H-D 41183), or radiant heating device, heat the crimped butt splice connector. Apply heat from the center of the crimp out to each end until the meltable sealant exudes out of both ends of the connector. Let the connector cool.

26. Slide the heat shrink tubing over the splice and using the UltraTorch UT-100 (H-D 39969), Robinair Heat Gun (HD 25070) with Heatshrink Attachment (H-D 41183), or radiant heating device, heat the heat shrink tubing to encapsulate the butt splice connection. Apply heat from the center of the crimp out to each end.

▲ WARNING

When routing wires and harnesses, ensure that they are clear of moving parts, heat sources and pinch points to avoid wire damage or a short circuit, which could cause loss of control resulting in death or serious injury. (00554b)

27. Position harness along fork tube and secure with cable straps.
28. Test operation of directional lights and running lights. If operation is not correct, verify that the wire splices were made properly.
29. Align entire assembly and tighten all mounting hardware. Replace lens on directional housing using Loctite 243 (Blue).

C. Relocating Bullet Style Three-Wire Directionals:

NOTE

On 2001 FXDX and all other models equipped with Bullet Style Directionals, it will be necessary to disassemble directional light and install grommets included in kit.

1. Follow instructions in applicable Service Manual and remove fuel tank.

NOTE

Before removing directional wires, carefully note wire routing. In particular, pay close attention to cable straps, which must be replaced. Also, when performing the next Step, before removing pin terminals from connector, carefully note terminal locations.

2. Locate front directional connector (pull from inside frame backbone) and separate connector halves. Cut cable straps around directional harness conduit. Refer to Appendix covering Amp Multilock Electrical Connectors in Service Manual and remove pin terminals from connector (from directionals) to free wiring harness. Leave conduit in place.

3. Unplug existing molded grommet from directional housing and carefully cut and remove grommet from wire harness.
4. See Figure 8. Thread new grommet (P/N 11443) from kit onto directional wire harness and move into position shown. Install grommet into directional housing. It may be helpful to apply water to ease installation.

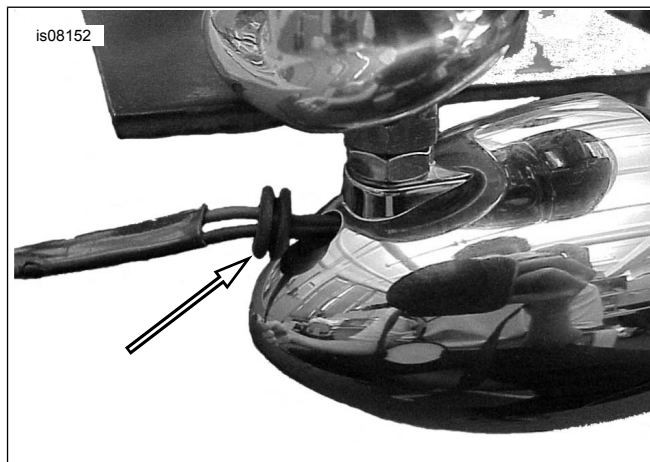

Figure 8. Install Grommet From Kit

5. If passing lamp kit is already installed and wired to vehicle, cut the lead wire from the passing lamp kit at the handlebar clamp as close to the joining butt splice as possible. Cut off the butt splice as this will be replaced with new splice from kit. See Figure 3. Remove retaining nut from passing lamp and discard.
6. Remove directional lens from housing.
7. See Figure 9. Route passing lamp lead wire through new retaining nut and install new retaining nut (P/N 68323- 01) to passing lamp threads. Snug retaining nut into place.
8. Install jam nut to threads on retaining nut as shown.

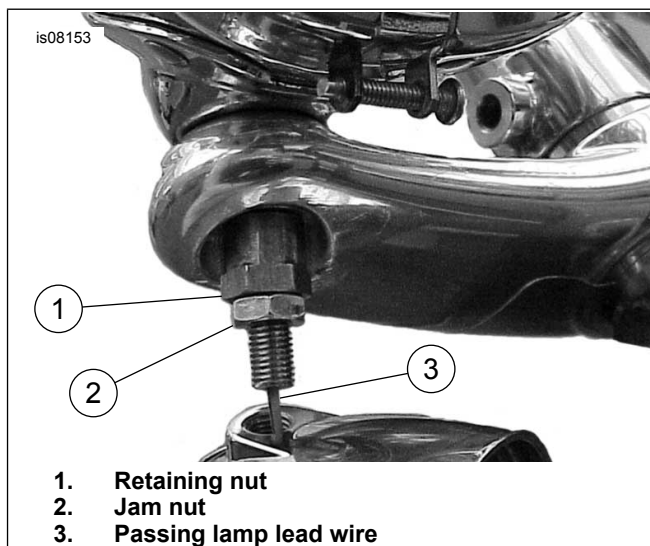

Figure 9. Install Retaining Nut and Jam Nut

9. Loosen directional inner housing with a small screwdriver and disassemble to allow access for wire routing.

NOTE

When performing the next Step, It will be necessary to use an open-end wrench to gain complete access to jam nut.

10. See Figure 10. Thread directional onto retaining nut until snug, then back off the minimum amount to allow forward alignment of lamp housings. Snug jam nut against directional housing to lock in place.

NOTE

The grommet included in this kit does not form a watertight seal. A path must be provided to allow any water to exit from the directional housing. To provide for water drainage, carefully follow Steps a and b.

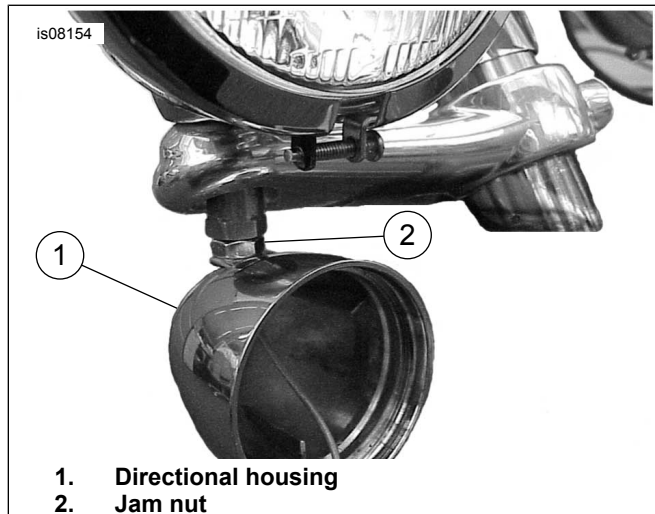

Figure 10. Install Directional

11. See Figure 11. Route passing lamp lead wire through directional housing grommet.

- a. Refer to Figure 12. Locate the 3 slots that align the o-ring gasket to the directional housing. Cut a 3/8 in. (9.5 mm) (approximate) section out of the O-ring at the bottom, center slot, position.
- b. See Figure 13. Install the O-ring and inner housing into the directional housing with the cutout oriented at the bottom as shown.
- c. See Figure 14. Install the directional lens with slots oriented down and in line with the O-ring slot as shown.

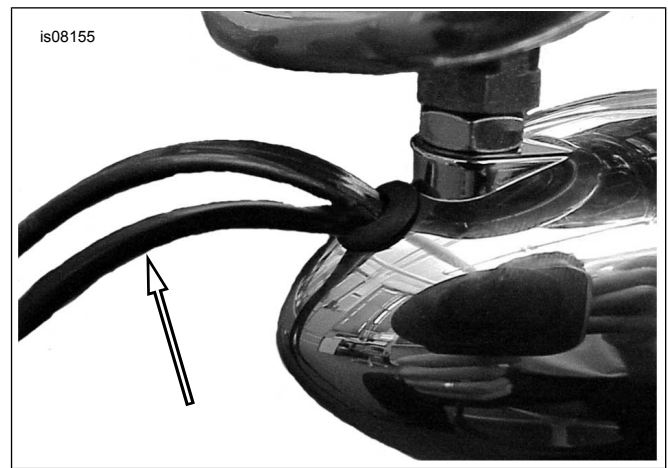

Figure 11. Route Passing Lamp Lead Wire

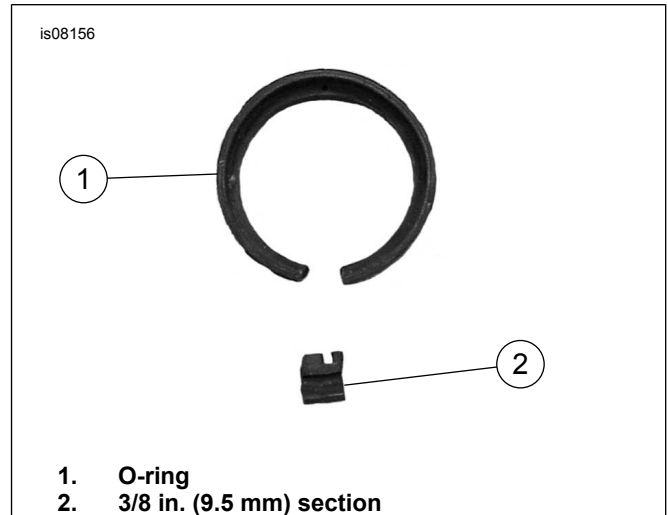

Figure 12. Modify O-ring

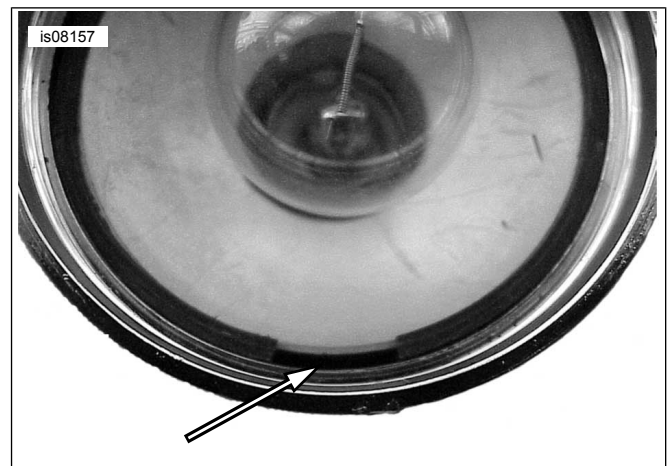

Figure 13. Install O-Ring



Figure 14. Install Directional Lens (Bottom View)

12. Route the directional wires back to connector (at frame backbone) and secure with tie straps as needed.

NOTE

In some cases, after routing, the wires may be too short to reach the connector. If this is the case, perform Steps 11 through 24. If wires are of adequate length, proceed to Step 24.

13. Cut the directional light wires (at the terminal ends) to the following lengths:
 - a. Blue Wire-1-1/4 in. (31.7 mm) from terminal.
 - b. Violet Wire-2-1/4 in. (57.1mm) from terminal.
 - c. Black Wire-3-1/4 in. (82.5 mm) from terminal.

NOTE

The wires are cut at different lengths to stagger the butt connectors preventing a large bulge in the harness.

14. Strip 5/16 in. (7.9 mm) of insulation from the cut ends of the three wires.
15. Crimp butt-splice connectors from kit on the three short terminal ends of the wires.
16. Measure and cut three 6 inch lengths of blue, violet and black wire from kit that will enable wires to reach connector.
17. Strip 5/16 inch of insulation from one end of each wire. Connect the like colored wires and crimp onto butt-splice connectors installed in Step 13.
18. Slide shrink tubing from kit over crimped terminals.
19. Cut an appropriate length of 5/16 in. (7.9 mm). ID vinyl tubing supplied in kit.
20. Slide vinyl tubing onto three wires connected in step 15 and over existing conduit.

21. Cut the three spliced-on wires to lengths required for connection to the directional light. Make certain to leave enough slack to allow routing harness along fork tube.
22. Slide heat shrink tubes over the three wire ends.
23. Strip 5/16 in. (7.9 mm) of insulation from remaining wire ends and connect like colored wires at directional light with sealed butt connectors from kit.
24. Slide heat shrink tubing over connectors installed in Steps 15 and 21. Activate shrink tubing with UltraTorch UT-100, heat gun or hair dryer, noting the following:

▲ WARNING

Be sure to follow manufacturer's instructions when using the UltraTorch UT-100 or any other radiant heating device. Failure to follow manufacturer's instructions can cause a fire, which could result in death or serious injury. (00335a)

- **Avoid directing heat toward any fuel system component. Extreme heat can cause fuel ignition/explosion resulting in death or serious injury.**
- **Avoid directing heat toward any electrical system component other than the connectors on which heat shrink work is being performed.**
- **Always keep hands away from tool tip area and heat shrink attachment.**

▲ WARNING

Be sure to follow manufacturer's instructions when using propane torches. Failure to follow manufacturer's instructions can cause a fire, which could result in death or serious injury. (00465c)

- **Avoid directing heat toward any fuel system component.**
 - **Extreme heat can cause fuel ignition/explosion resulting in death or serious injury.**
 - **Avoid directing heat toward any electrical system component other than the connectors on which heat shrink work is being performed.**
 - **Always keep hands away from tool tip area and heat shrink attachment.**
25. Slide the 5/16 inch vinyl tubing, installed in Step 18 over all new connections.
 26. Following instructions in appendix covering Amp MultiLock Electrical Connectors in Service Manual, reconnect turn signal.
 27. Install a cable strap to secure the wiring to the 5/16 in. (7.9 mm) tubing next to directional light.
 28. Repeat Steps 1 through 25 to connect opposite directional light.
 29. Refer to Figure 7. Bring both passing lamp wires to the connector. Trim the wires, allowing approximately 1 inch (25 mm) of wire to extend past the butt splice connector. Trim the conduit approximately 1-1/2 inch (38 mm) back from the end of the wire.
 30. Remove approximately 3/8 inch (10 mm) of insulation from the end of the passing lamp wires.

31. Insert the ends of both passing lamp wires into the electrical connector and crimp the wires to the connector using a H-D 38125-8 Crimping Tool.

⚠ WARNING

Be sure to follow manufacturer's instructions when using the UltraTorch UT-100 or any other radiant heating device. Failure to follow manufacturer's instructions can cause a fire, which could result in death or serious injury. (00335a)

- **Avoid directing heat toward any fuel system component. Extreme heat can cause fuel ignition/explosion resulting in death or serious injury.**
- **Avoid directing heat toward any electrical system component other than the connectors on which heat shrink work is being performed.**
- **Always keep hands away from tool tip area and heat shrink attachment.**

⚠ WARNING

Be sure to follow manufacturer's instructions when using the Robinair Heat Gun or any other radiant heating device. Failure to follow manufacturer's instructions can cause a fire, which could result in death or serious injury. (00379a)

- **Avoid directing heat toward any fuel system component.**
- **Extreme heat can cause fuel ignition/explosion resulting in death or serious injury.**
- **Avoid directing heat toward any electrical system component other than the connectors on which heat shrink work is being performed.**
- **Always keep hands away from tool tip area and heat shrink attachment.**

NOTE

Protect the heat shrink tubing from the heat source while applying heat to the electrical connector.

32. Slide the heat shrink tubing (1) away from the splice and using the UltraTorch UT-100 (H-D 39969), Robinair Heat Gun (H-D 25070) with Heatshrink Attachment (H-D 41183), or radiant heating device, heat the crimped butt splice connector. Apply heat from the center of the crimp out to each end until the meltable sealant exudes out of both ends of the connector. Let the connector cool.

33. Slide the heat shrink tubing over the splice and using the UltraTorch UT-100 (H-D 39969), Robinair Heat Gun (HD 25070) with Heatshrink Attachment (H-D 41183), or radiant heating device, heat the heat shrink tubing to encapsulate the butt splice connection. Apply heat from the center of the crimp out to each end.

⚠ WARNING

When routing wires and harnesses, ensure that they are clear of moving parts, heat sources and pinch points to avoid wire damage or a short circuit, which could cause loss of control resulting in death or serious injury. (00554b)

34. Position harness along fork tube and secure with cable straps.

⚠ WARNING

Connect positive (+) battery cable first. If positive (+) cable should contact ground with negative (-) cable connected, the resulting sparks can cause a battery explosion, which could result in death or serious injury. (00068a)

35. Reconnect the battery cables (positive cable first). Test operation of directional lights and running lights. If operation is not correct, verify that wire splices are made correctly.

36. Align entire assembly and tighten all mounting hardware.

37. See the Service Manual. Install fuel tank.

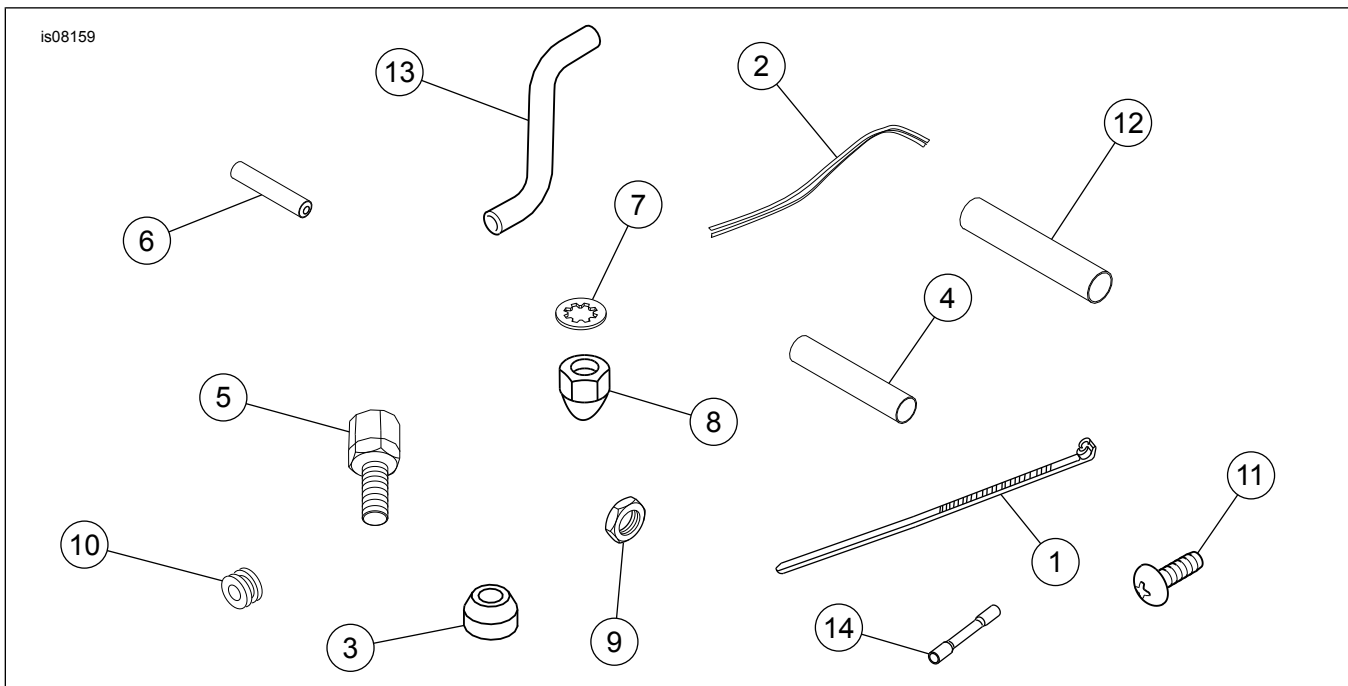

Figure 15. Service Parts

Table 1. Service Parts

Item	Description (Quantity)	Part Number
1	Strap, cable (6)	10006
2	Wire, 2 conductor (polarized)	32695-87
3	Spacer, mirror mount	5774
4	Heat shrink conduit (12)	67113-83
5	Retainer, passlamp/turn sig (2)	68323-01
6	Connector (12)	70581-73
7	Lockwasher, int tooth (3)	7127
8	Nut, acorn	7736
9	Nut, jam (2)	7912
10	Grommet (2)	11443
11	Screw, button head (2)	4351
12	Heat shrink conduit 5/16 inch	72266-94
13	Tubing, vinyl 5/16 inch	70510-95
14	Connector, sealed butt	70586-93
15	Wire, 18 gauge (Black) not shown	not sold/shown
16	Wire, 18 gauge (violet) not shown	not sold/shown
17	Wire, 18 gauge (blue)	not sold/shown