



INSTRUCTIONS

J03496

2005-03-16



DECORATIVE WHEEL WEIGHTS

GENERAL

Models

These kits are designed to fit all model motorcycles.

Additional Parts Required

▲ WARNING

Rider and passenger safety depend upon the correct installation of this kit. Use the appropriate service manual procedures. If the procedure is not within your capabilities or you do not have the correct tools, have a Harley-Davidson dealer perform the installation. Improper installation of this kit could result in death or serious injury. (00333b)

NOTE

This instruction sheet references Service Manual information. A Service Manual for your model motorcycle is required for this installation and is available from a Harley-Davidson Dealer.

Kit Contents

See Figure 1 and Table 1.

There are no Service Parts available with this kit.

NOTE

A precision balancing machine is used in the installation of wheel weights. It is recommended that a Harley-Davidson Dealer perform the installation.

INSTALLATION

NOTE

The maximum weight permissible to accomplish balance is 99 g (3.5 oz.) total weight applied on the rim. Refer to the appropriate Service Manual for Wheel Balancing procedures.

Adhesive Wheel Weight Installation

NOTE

When installing the adhesive type wheel weights, ensure that area of application is completely clean, dry and free of oil and grease.

1. Remove paper backing from weight and apply 3 drops of Loctite 420 (Superbond) to the adhesive side of the weight.
2. Place weight on the rim, press firmly in place and hold for 10 seconds. Full adhesive cure takes 8 hours.

Laced Wheel Weight Installation

NOTE

Never strike one hammer against a hardened object, such as another hammer. Laced wheels use balance weights which press over the spoke nipples.

1. Place weight onto spoke and press over spoke nipple until fully seated.

Maintenance and Cleaning

Chrome parts must be maintained regularly to ensure that they keep their original shine and luster.

1. Clean heavily-soiled wheel surfaces using Harley Wheel and Tire Cleaner, Part No. 94658-98, applied with Harley Wheel and Spoke Brush, Part No. 43078-99.
2. Thoroughly clean chrome with a good quality chrome cleaner, such as Harley Bright Chrome Cleaner, Part No. 94683-99.
3. After cleaning and polishing, seal the finish with a good quality sealer such as Harley Glaze Polish and Sealant, Part No. 99701-84.

SERVICE PARTS

See Figure 1 and Table 1.



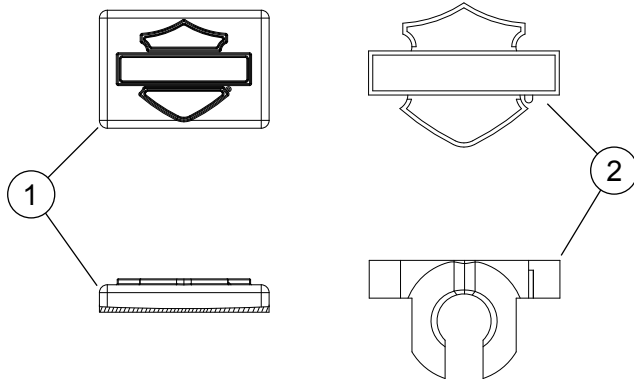

Figure 1. Service Parts: Decorative Wheel Weight Kits

Table 1. Service Parts Table

Self Adhesive Wheel Weights			Laced Wheel Weights		
Item	Description (Quantity)	Part Number	Item	Description (Quantity)	Part Number
1	Wheel weight	Not sold separately	2	Wheel weight	Not sold separately