



INSTRUCTIONS

J00325

2005-11-16



DETACHABLE WINDSHIELD AND DOCKING HARDWARE KIT

GENERAL

Kit Number

57965-97A, 58340-96, 58341-96, 58350-96, 58627-99, 58678-04, 57813-04

Models

These kits fit 1984 and later FXST, FXSTB, FXSTC, and 1993 and later FXDWG Harley-Davidson model motorcycles.

Table 1. Models

Kits	Contents
57813-04	Clear standard height windshield with flames
57965-97A	Smoked Super Sport windshield
58340-96	Clear standard height windshield
58341-96	Smoked low profile windshield
58350-96	Docking hardware
58627-99	Smoked standard height windshield
58678-04	Clear "Skull with Wings" windshield

NOTICE

Do not use windshield bags with flamed windshields. Damage to graphics will occur. (00393f)

NOTE

A Service Manual for your model motorcycle is available from your Harley-Davidson Dealer.

Kit Contents

See Figure 5, Table 2 and Figure 6, Table 3 and Figure 7, Table 4.

INSTALLATION

⚠ WARNING

Rider and passenger safety depend upon the correct installation of this kit. Use the appropriate service manual procedures. If the procedure is not within your capabilities or you do not have the correct tools, have a Harley-Davidson dealer perform the installation. Improper installation of this kit could result in death or serious injury. (00333b)

1. Cover gas tank and front fender before beginning installation.

2. **For FXSTB models:** Proceed to Step 6. **For all other models except FXSTB:** Relocate clutch cable to the inside of the handlebars as follows:
 - a. Slide rubber boot off cable adjuster. Adjuster is located approximately halfway along clutch cable by the front frame downtube.
 - b. Holding cable adjuster with 1/2 inch wrench, loosen jam nut using a 9/16 inch wrench. Back jam nut away from cable adjuster. Move adjuster toward jam nut to introduce a large amount of free play at the hand lever.
 - c. Remove small snap ring from pivot pin groove at bottom of clutch lever bracket. Remove pivot pin and clutch hand lever from bracket. Remove anchor pin and clutch cable eyelet from clutch hand lever.
 - d. See Figure 1. Reroute clutch cable to the inside of the handlebars and reconnect clutch cable to clutch lever.
 - e. See Figure 2. Turn cable adjuster away from jam nut until slack is eliminated at hand lever. Pull clutch cable ferrule away from clutch lever bracket to check free play. Turn cable adjuster as necessary to obtain 1/16-1/8 inch (1.6-3.2 mm) free play between end of cable ferrule and clutch lever bracket.
 - f. Hold adjuster with 1/2 inch wrench. Using 9/16 inch wrench, tighten jam nut against cable adjuster. Cover cable adjuster mechanism with rubber boot.

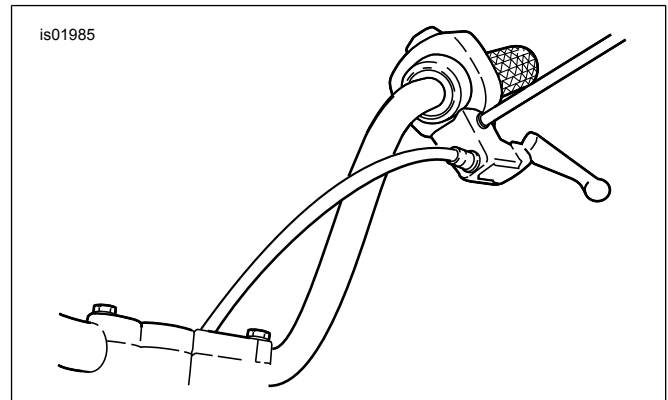

Figure 1. New Clutch Cable Routing



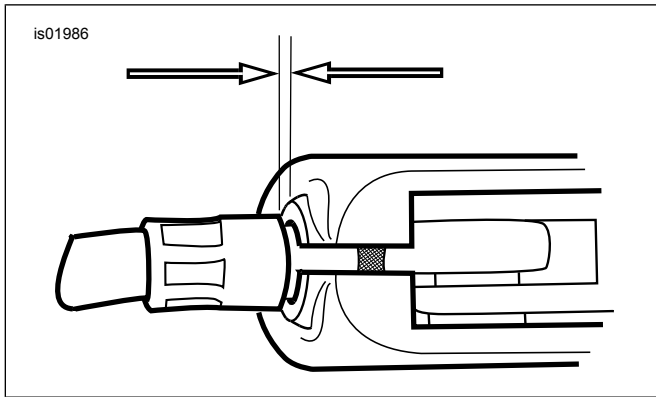

Figure 2. 1/16-1/8 inch (1.6-3.2 mm) Clutch Cable Free Play

3. **On all models except FXSTB:** Remove turn signal lamp from right side of handlebar (brake side). Remove ball receptacle from turn signal assembly. Install lockwasher (12) and chrome acorn nut (11) from kit on end of mirror stalk to hold mirror in place.
4. Remove turn signal lamp from left side of handlebar (clutch side). Remove ball receptacle mount from turn signal assembly. Replace acorn nut and lockwasher.
5. Remove brake line clamp on upper fork triple clamp to allow right turn signal lamp to pass between brake line and right handlebar riser. All models except FXSTB skip to Step 7.
6. **On FXSTB models only:** Remove existing turn signal clamps from fork tubes. Remove the original turn signal standoff from the turn signal. The original clamp and standoff will not be used during re-assembly.
7. See Figure 5. Assemble mounting hardware for lower windshield mounting as shown in illustration. Assemble in the following order, and leave assembly loose:
 - a. Locate the mounting hardware supplied in the docking hardware kit. Thread jam nut (9) from mounting kit onto the turn signal standoff end that is opposite the end with the flats (3).
 - b. Thread standoff into turn signal assembly with jam nut facing turn signal.
 - c. Place flat washer (5) and bushing (4) on standoff.
 - d. Thread the clamp (8) onto the standoff.
 - e. Install clamp assembly onto the fork tube with the clamp nut forward toward the headlamp.

NOTICE

Do not exceed recommended torque when installing mounting screws. Damage to windshield can result. (00385a)

8. See Figure 5. Assemble hardware for upper windshield mounting as shown in illustration and tighten button head screws to 20 N·m (15 ft-lbs). The spacer (1), not visible in the illustration, fits between the retainer wire bracket (6, 7) and the upper fork triple clamp.

NOTE

Check for proper clearance between upper bushing and fuel tank before installing windshield as follows:

See Figure 3. Turn the front forks to the left, allowing the fork to rest against the fork stop. Measure the clearance between the fuel tank and the upper bushing. We recommend using the shank end of the proper size drill bit as a feeler gauge between the fuel tank and the upper bushing. Before checking the clearance, place a piece of paper against the fuel tank to eliminate the possibility of scratching the fuel tank paint. Repeat this process with the front forks rotated fully to the right fork stop. If clearance is less than 5/32 inch (4 mm), contact your Harley-Davidson Dealer for additional information (reference P&A Service Bulletin P-40).

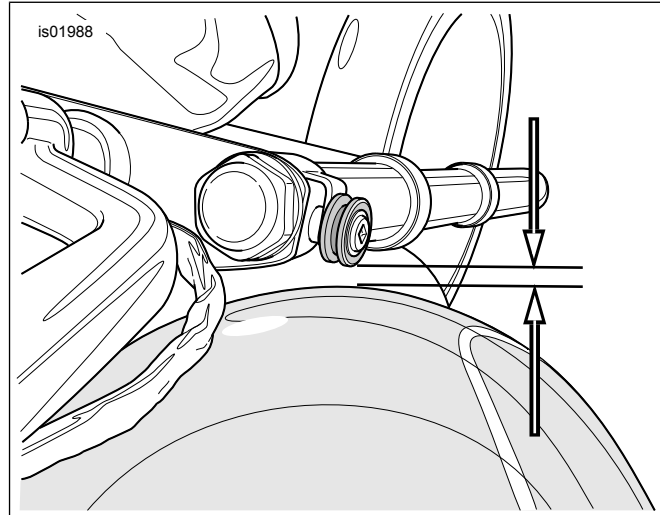

Figure 3. 5/32 inch Minimum Clearance between Fuel Tank and Upper Bushing (looking down on docking point from above)

9. Hook the two top windshield assembly "jaws" into the grooves of the top bushings (4) then slide the lower clamp assemblies up until the lower bushings firmly fit into the lower windshield "jaws".
10. With windshield in place, tighten lower clamp (8) hardware by first tightening clamp nut to 14 N·m (10 ft-lbs). Be sure the clamp does not rotate during tightening (the mounting bushing must be parallel to the windshield brackets).
11. With clamps secured to forks, tighten standoff into mounting clamp to 20 N·m (15 ft-lbs). Then, align turn signals and tighten jam nuts (9) to 14 N·m (10 ft-lbs).

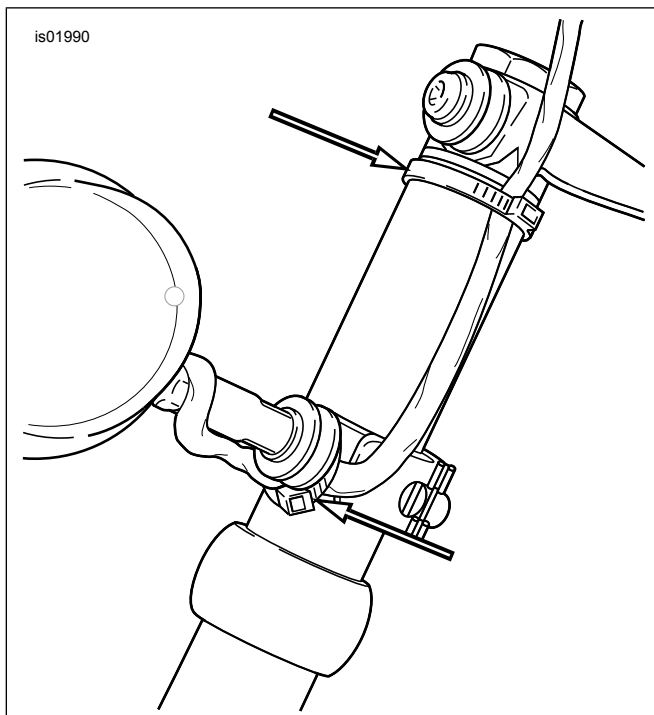

Figure 4. Cable Ties and Turn Signal Wire Routing

12. See Figure 4. Remove windshield by grabbing windshield edges parallel with center brace and firmly pulling windshield loose from upper bushing grooves. Lift windshield assembly off of lower bushings. With windshield removed, and using cable straps in kit, securely route turn signal wires. After wires are secured, check turn signal wire clearance with the windshield installed.
13. Reattach brake line clamp to upper fork triple clamp.

▲ WARNING

Improper installation of accessories or loading of cargo can affect motorcycle stability and handling, which could result in death or serious injury. (00455b)

▲ WARNING

Failure to provide adequate clearance between stationary and moving parts can cause loss of control, which could result in death or serious injury. (00378a)

NOTE

Inspect windshield upon completion of installation. Be sure windshield mounting does not restrict full left or full right movement of front fork assembly. Restricted movement could

affect handling, resulting in death or serious injury. If restriction does occur, adjust windshield as needed until proper clearance is obtained. Have experienced Harley-Davidson service personnel correct any problems before riding with this accessory installed.

NOTE

Check mounting hardware periodically. Never ride with loose mounts. A loose mounting causes extra stress on all other mounts, as well as the windshield itself, and could result in premature failure of components.

CARE AND CLEANING

NOTE

Sunlight reflections off of the inside curvature of a windshield can, at certain times of the day, cause extreme heat build-up on motorcycle instruments. Exercise care in parking. Park facing the sun, place an opaque object over the instruments, or adjust the windshield to avoid reflections.

NOTICE

Polycarbonate windshields/wind deflectors require proper attention and care to maintain. Failure to maintain polycarbonate properly can result in damage to the windshield/wind deflector. (00483e)

NOTICE

Use only Harley-Davidson recommended products on Harley-Davidson windshields. Do not use harsh chemicals or rain sheeting products, which can cause windshield surface damage, such as dulling or hazing. (00231c)

NOTICE

Use only Harley-Davidson recommended products on Harley-Davidson windshields. Do not use harsh chemicals or rain sheeting products, which can cause windshield surface damage, such as dulling or hazing. (00231c)

Do not clean Lexan[®] polycarbonate in hot sun or high temperature. Powdered, abrasive or alkaline cleanser will damage the windshield. Never scrape the windshield with a razor blade or other sharp instruments because permanent damage will result.

NOTE

Covering the windshield with a clean, wet cloth for about 15 minutes before washing will make dried bug removal easier.

Harley-Davidson Windshield Water Repellent Treatment part number 99841-01 is approved for use on Harley-Davidson Lexan[®] windshields.

SERVICE PARTS

is01992

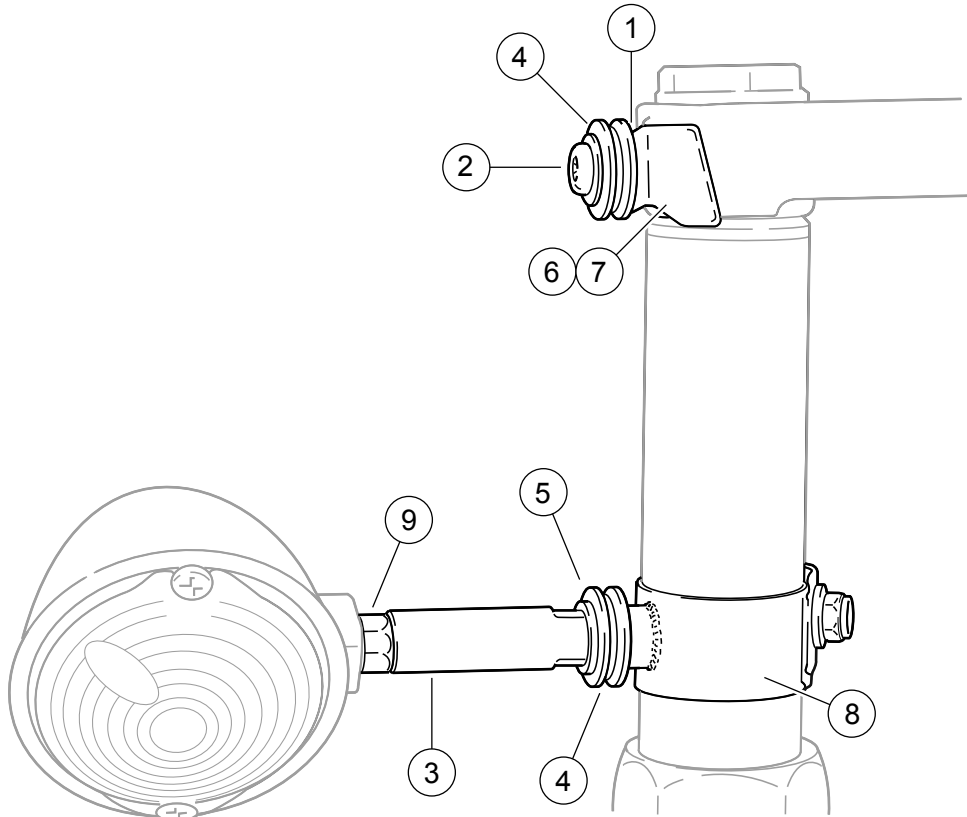

Figure 5. Service Parts: Docking Hardware

Table 2. Service Parts: Docking Hardware

Item	Description (Quantity)	Part Number	Item	Description (Quantity)	Part Number
1	Spacer (2)	58349-96	7	Right retainer wire bracket	58515-96
2	5/16-24 x 7/8 button head screws (2)	94467-94T	8	Mounting clamps (2)	58351-96
3	Turn signal standoffs (2)	58556-97	9	5/16-24 chrome nuts (2)	94043-90T
4	Bushings (4)	67621-94	10	Cable ties (6) (not shown)	10006
5	5/16 chrome flat washers (4)	94066-90T	11	5/16-24 chrome acorn nut (used on right side mirror) (not shown)	7736
6	Left retainer wire bracket	58514-96	12	5/16 internal tooth lockwasher (used on right side mirror) (not shown)	7127

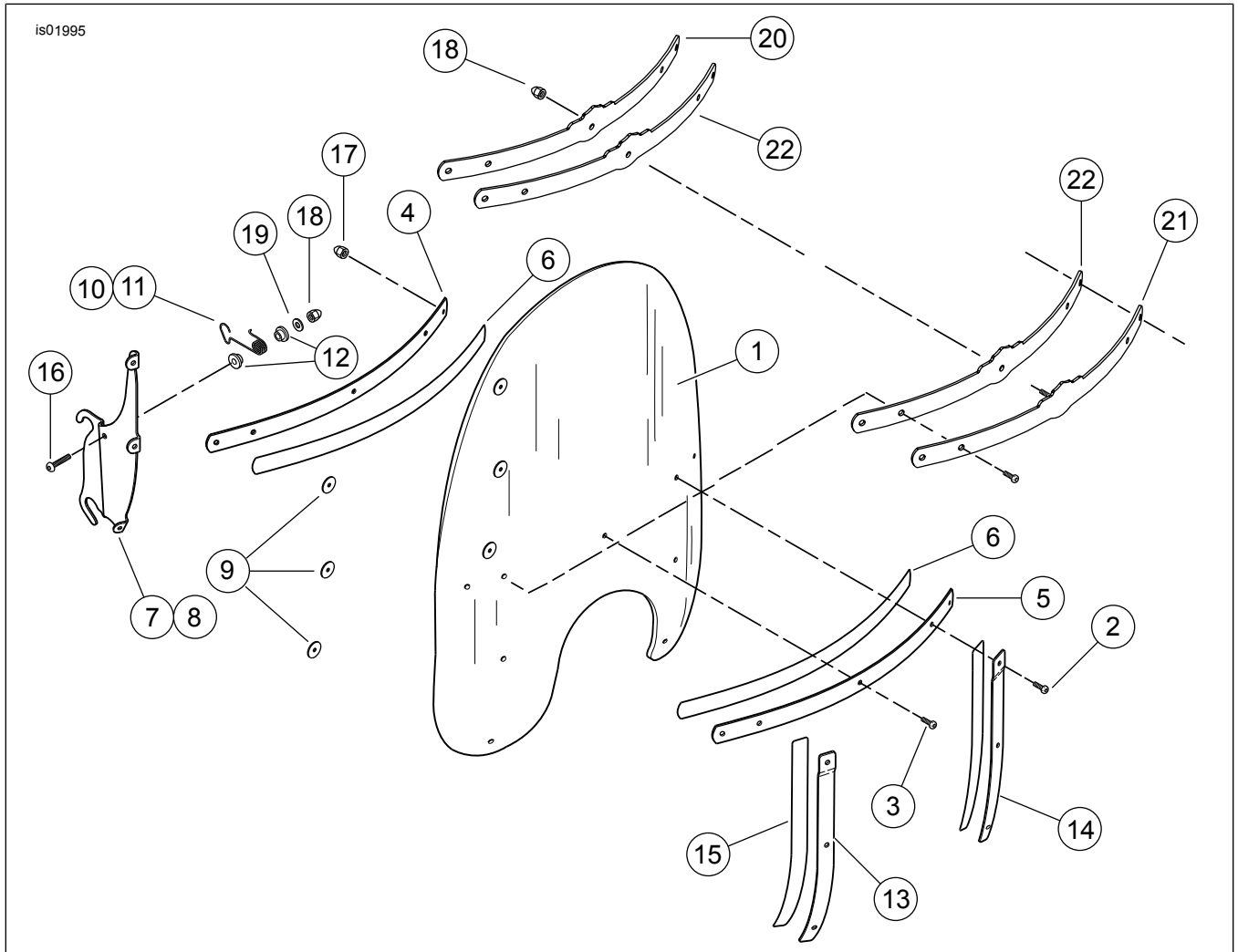

Figure 6. Service Parts: Windshield

Table 3. Service Parts: Windshield

Item	Description (Quantity)	Part Number	Item	Description (Quantity)	Part Number
1	Windshield		10	LH windshield retainer	58329-96
	For Kit 57813-04, standard height with flames	57815-04	11	RH windshield retainer	58328-96
	For Kit 58340-96, standard height, clear	58288-95	12	Nylon bushings (4)	58272-95
	For Kit 58341-96, low profile, smoked	58271-95	13	RH brace	58406-75A
	For Kit 58627-99, standard height, smoked	58629-99	14	LH brace	58408-75A
	For Kit 58678-04, standard height, clear	58288-95	15	Windshield brace tape (2)	58417-77
2	Pan head screws, Torx (2)	2452	16	Button head screws (2)	94426-95
3	Pan head screws, Torx (7)	2921	17	Acorn nuts (9)	7651
4	Inner windshield brace	58050-78A	18	Acorn nuts, 1/4-20 (3)	94004-90T
5	Outer windshield brace	58051-78A	19	Flat washers, 1/4 inch (2)	6703
6	Windshield brace tape (2)	58052-78	For Kit 58678-04 only		
7	LH windshield bracket	58344-96	20	Inner windshield brace	58551-04
8	RH windshield bracket	58345-96A	21	Outer windshield brace	58550-04
9	Washers (6)	58152-96	22	Windshield brace tape (2)	58540-04

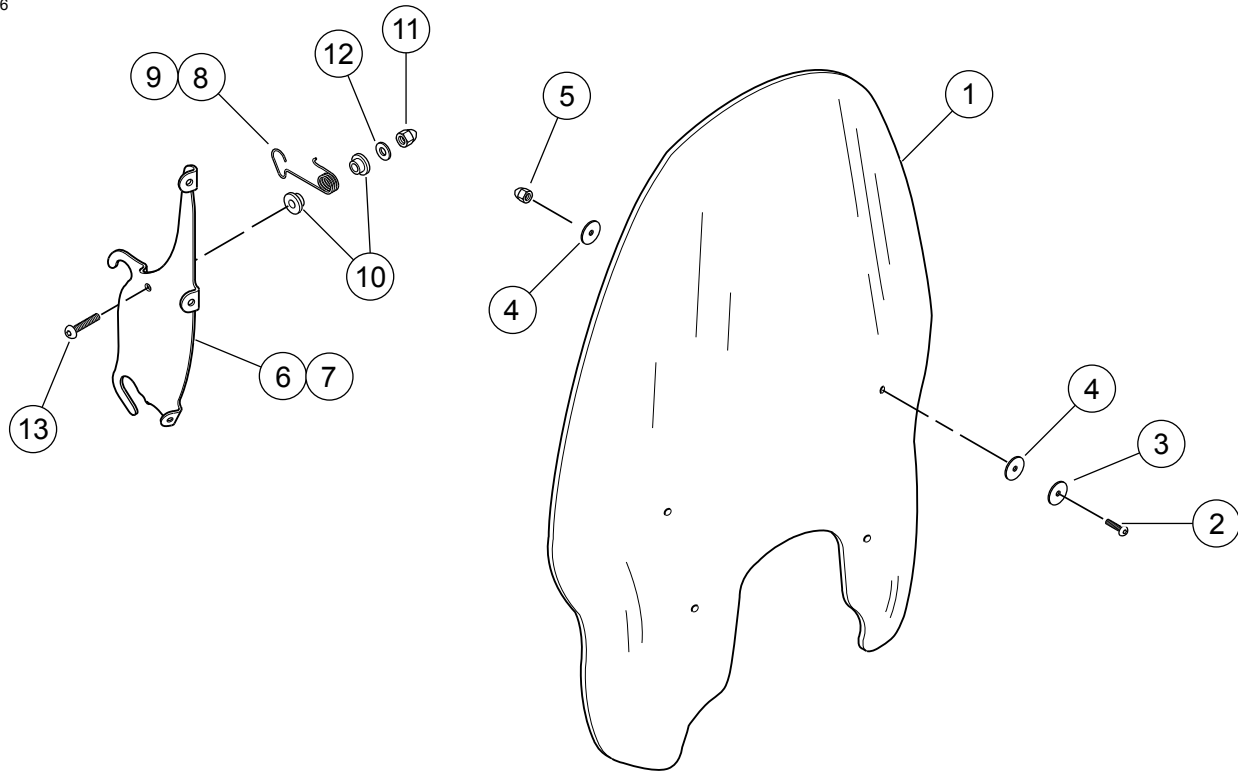

Figure 7. Service Parts: Windshield Kits

Table 4. Service Parts: Windshield Kits

Item	Description (Quantity)	Part Number	Item	Description (Quantity)	Part Number
1	Windshield	57731-98	8	LH windshield retainer	58329-96
2	Button head screws (4)	94639-99	9	RH windshield retainer	58328-96
3	Washers (4)	6352	10	Nylon bushings (4)	58272-95
4	Washers, rubber (8)	58152-96	11	Acorn nuts, 1/4-20 (2)	94004-90T
5	Acorn nuts (4)	94007-90T	12	Flat washers, 1/4 inch (2)	6703
6	LH windshield bracket	57967-97A	13	Button head screws (2)	94426-95
7	RH windshield bracket	57968-97A			