



INSTRUCTIONS

J01221

2009-01-06



CLUTCH CABLE FERRULE COVER AND BANJO BOLT COVER

GENERAL

Kit Number

32714-98A and 32715-98

Models

Kit 32714-98A fits 1984 and later models with stock master cylinders and calipers (except 02 and later VRSC, and 04 and later XL models). (This kit will not fit models equipped with a hydraulic clutch).

Kit 32715-98 fits 1984 and later models with stock master cylinders and calipers. (This kit does not fit VRSC master cylinders, 06 and later VRSC calipers, or 04 and later XL models)

INSTALLATION of CLUTCH CABLE FERRULE COVER

1. Separate two halves of ferrule cover with a 3/32 inch allen wrench.
2. See Figure 1. Place cover halves over ferrule and reassemble. If cover does not fit the ferrule tightly, remove cover and install the two pieces of loose tape (included in the kit) onto the inner surface of each cover half. If the cover continues to not fit tightly wrap black electrical tape around ferrule until a secure fit is achieved. Replace cover and tighten allen screws.

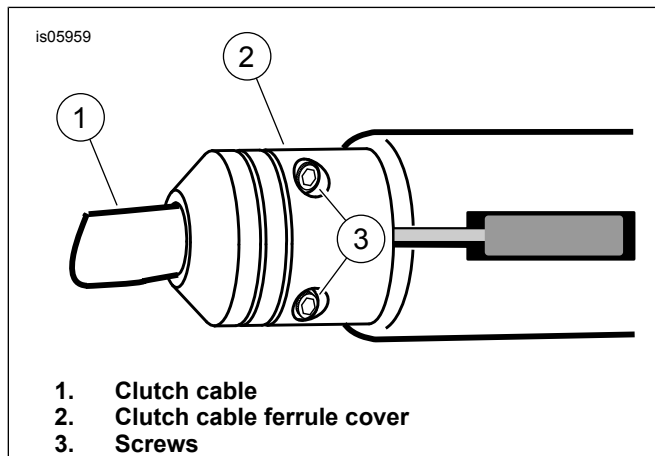

Figure 1. Chrome Clutch Ferrule Installed

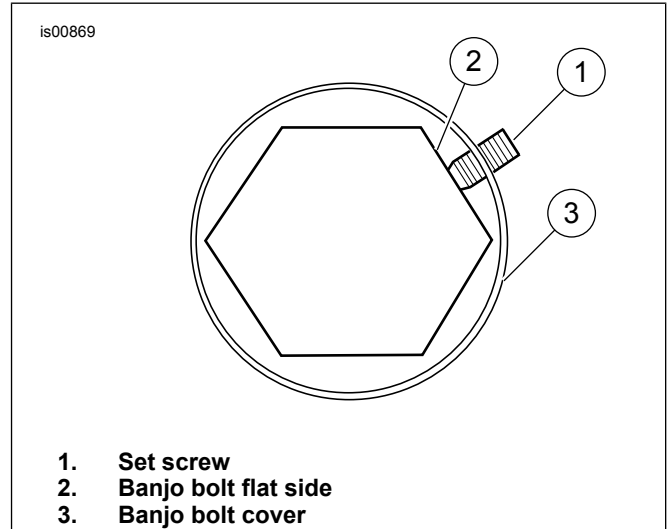

Figure 2. Set Screw Orientation

INSTALLATION of BANJO BOLT COVER

1. See Figure 2. Position banjo bolt cover (3) over banjo bolt making certain that set screw (1) contacts flat surface (2) of banjo bolt.
2. See Figure 3. With a 5/64 inch allen wrench, tighten set screw to hold the cover securely in place.
3. See Figure 4. Banjo bolt cover (1) is positioned with set screw (2) toward the underside of banjo bolt.



Figure 3. Installed Banjo Bolt Cover

is00871

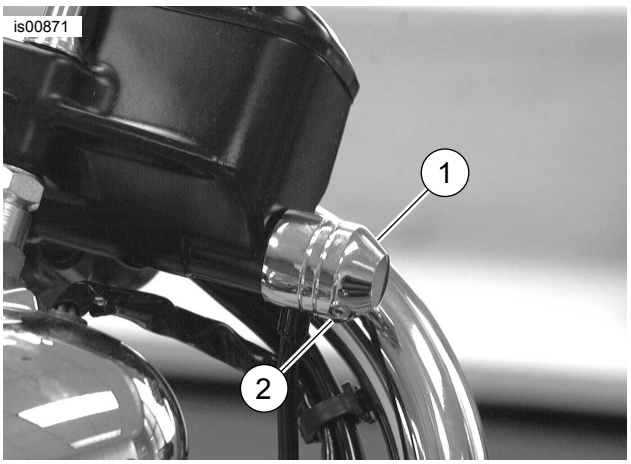

1. Banjo Bolt Cover
2. Set Screw

Figure 4. Set Screw Location on Banjo Bolt Cover