



INSTRUCTIONS

J02239

2005-09-09



CHROME SLOTTED HAND CONTROL LEVERS

GENERAL

Kit Number

45459-02, 45533-02

Models

Kit number 45459-02 is designed for installation on all 1996 and later model motorcycles except VRSCA.

Kit number 45533-02 is designed for installation on all VRSCA model motorcycles and all models with a hydraulic clutch.

Additional Parts Required

⚠ WARNING

Rider and passenger safety depend upon the correct installation of this kit. Use the appropriate service manual procedures. If the procedure is not within your capabilities or you do not have the correct tools, have a Harley-Davidson dealer perform the installation. Improper installation of this kit could result in death or serious injury. (00333b)

NOTE

This instruction sheet references Service Manual information. A Service Manual for your model motorcycle is required for this installation and is available from a Harley-Davidson Dealer.

Kit Contents

See Table 1 and Table 2.

INSTALLATION

Brake Lever

NOTICE

Do not remove or install the master cylinder assembly without first positioning a 5/32-inch (4 mm) thick insert between the brake lever and lever bracket. Removing or installing the master cylinder assembly without the insert in place may result in damage to the rubber boot and plunger on the front stoplight switch. (00324a)

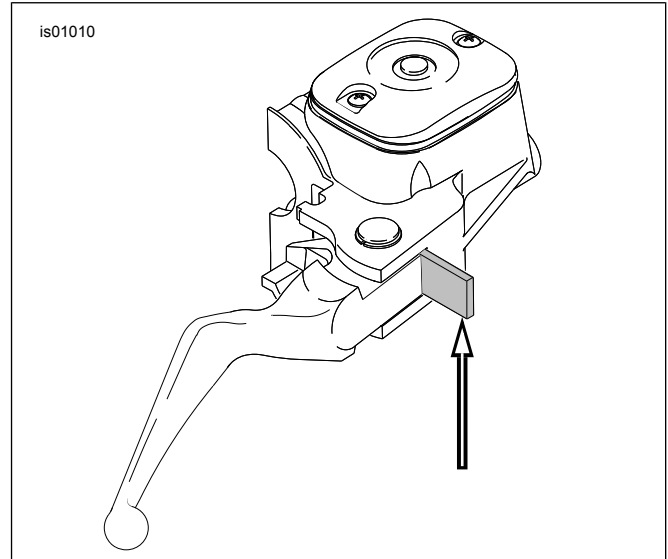

Figure 1. 5/32 in. (4 mm) Cardboard Insert

1. See Figure 1. Squeeze the brake lever and place the cardboard insert between the brake lever and lever bracket.

NOTE

Use the eyelet of an ordinary cable strap if the cardboard insert is not available.

NOTE

Do not remove handlebar clamp or switch housing assembly to remove brake lever.

⚠ WARNING

Wear safety glasses or goggles when removing or installing retaining rings. Retaining rings can slip from the pliers and could be propelled with enough force to cause serious eye injury. (00312a)

2. Refer to the applicable 1996 or later Service Manual, FRONT BRAKE MASTER CYLINDER - 1996, and remove the retaining ring from the groove in the pivot pin. Save retaining ring for reuse.
3. Remove pivot pin and original equipment brake lever. Retain pivot pin for reuse.

NOTE

Follow the instructions in Steps 4 and 5 carefully to prevent the actuating tab on the brake lever from damaging the rubber boot and plunger of the front stoplight switch.

4. Gently press piston cap forward with a screwdriver and hold it in the forward position.

5. Slip the brake lever into position and align the pivot pin holes.
6. Install pivot pin and retaining ring removed in Steps 2 and 3.
7. Check front brake for proper operation. There should be no free play in the hand lever. A slight preload is permissible.
8. Remove master cylinder reservoir cover to check the operation of the relief port

▲ WARNING

Be sure the master cylinder relief port is not plugged. A plugged relief port can cause brake drag or lockup and loss of vehicle control, which could result in death or serious injury. (00317a)

9. Reinstall master cylinder cover.
10. Check that stop light is on when brake lever is actuated.

Clutch Lever

See appropriate Service Manual for all clutch lever removal, installation and adjustment procedures.

Emblem

NOTE

When installing the emblems, make sure text is positioned properly.

1. Clean bonding surface on levers with isopropyl alcohol.
2. Remove backing, carefully position emblem and apply steady, even pressure for at least five seconds.
3. Allow 24 hours for adhesive to fully cure.

SERVICE PARTS

Table 1. Service Parts: Chrome Slotted Hand Control Lever Kit 45459-02

Item	Description (Quantity)	Part Number
1	Brake lever	45391-02
2	Clutch lever	45514-02
3	Emblem	44418-02
4	Emblem	44419-02

Table 2. Service Parts: Chrome Slotted Hand Control Lever Kit 45533-02

Item	Description (Quantity)	Part Number
1	Brake lever	45391-02
2	Clutch lever	45658-02
3	Emblem	44418-02
4	Emblem	44419-02