



INSTRUCTIONS

J01673

2006-09-08



CHROME SPROCKET HARDWARE KIT

GENERAL

Kit Number

94773-00, 94773-00A

Models

For model fitment information, please see the P&A Retail Catalog or the Parts and Accessories section of www.harley-davidson.com (English only).

Additional Parts Required

⚠ WARNING

Rider and passenger safety depend upon the correct installation of this kit. Use the appropriate service manual procedures. If the procedure is not within your capabilities or you do not have the correct tools, have a Harley-Davidson dealer perform the installation. Improper installation of this kit could result in death or serious injury. (00333b)

NOTE

This instruction sheet references Service Manual information. A Service Manual for your model motorcycle is required for this installation and is available from a Harley-Davidson Dealer.

Loctite® 262 (red), Harley-Davidson Part Number 94759-99, is available from a Harley-Davidson Dealer

Kit Contents

Table 1. Kit Contents

Description (Quantity)	Part Number
Cap screw, hex head, chrome (5)	Not Sold Separately
Washer, chrome (5)	Not Sold Separately

INSTALLATION

1. Remove the rear wheel. Refer to REAR WHEEL REMOVAL in the Service Manual.
2. Remove all stock sprocket mounting screws and washers.
3. Place a new chrome washer onto the threads of each new chrome screw from the kit. Apply 2-3 drops of Loctite 262 (red) to the screw threads, and install the sprocket onto the wheel. Tighten all screws finger-tight.
4. See Figure 1. Tighten the screws in the sequence shown to 31.2 N·m (23 ft-lbs).

NOTE

If 23 ft-lbs (31.2 Nm) is reached before screw is fully seated, remove screw and examine screw and wheel for thread damage. Replace screw if threads are damaged.

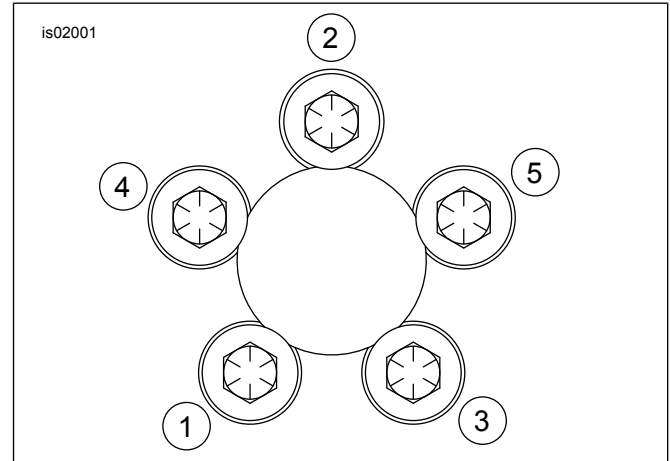
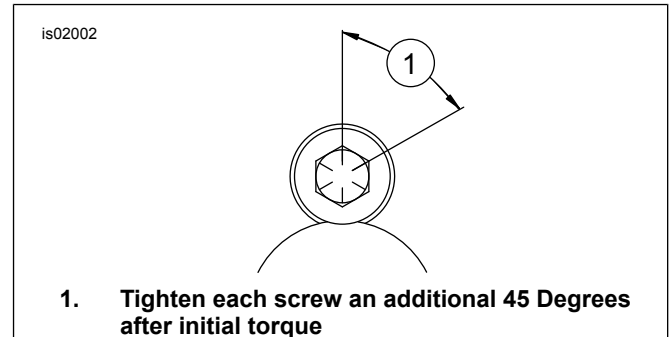

Figure 1. Torque Sequence, Sprocket

5. See Figure 2. After all screws have been tightened to 23 ft-lbs (31.2 Nm), mark a straight line, with a grease pencil, on all sprocket screw heads continuing the line over onto the sprocket.



1. Tighten each screw an additional 45 Degrees after initial torque

Figure 2. Additional Torque Sequence

6. Mark a second line at 45 degrees clockwise from the lines on the sprocket at each screw.

NOTE

For best results, use Snap-on Torque Angle Gauge TA360 or equivalent.

7. Using the marks as a guide, and using the tightening sequence shown in Figure 1, turn each screw an additional 1/8 turn or 45 degrees clockwise.
8. Re-install the rear wheel. See REAR WHEEL INSTALLATION in the Service Manual. Verify the correct axle alignment and check belt deflection per Service Manual instructions.