



INSTRUCTIONS

J01290

2013-11-01



XL (SPORTSTER) ENGINE GUARD

GENERAL

Kit Number

49018-88C

Models

For model fitment information, see the P&A retail catalog or the Parts and Accessories section of www.harley-davidson.com (English only).

▲ WARNING

Rider and passenger safety depend upon the correct installation of this kit. Use the appropriate service manual procedures. If the procedure is not within your capabilities or you do not have the correct tools, have a Harley-Davidson dealer perform the installation. Improper installation of this kit could result in death or serious injury. (00333b)

NOTE

This instruction sheet references Service Manual information. A Service Manual for your model motorcycle is required for this installation and is available from a Harley-Davidson Dealer.

Kit Contents

See Figure 4 and Table 1.

▲ WARNING

If Equipped: Front and/or rear guards are not intended to provide protection from bodily injury in a collision with another vehicle or any other object. (00022d)

NOTE

This kit can also be installed on 1982 through early 1984 XL and XR-1000 models (equipped with generator) with the purchase of short engine guard support bracket, Part Number 49014-85. Part 49014-85 is not included with this kit. Installation procedures for 1982 to early 1984 vehicles are on Page 2.

Cover front fender with a clean rag to protect it from scratches during installation procedures.

Installation - Late 1984 and Later XL Models (Equipped With Alternator)

NOTE

Late 1994 and 1995 XL vehicle nut plates have 3/8-16 threads. Reuse original screws on late 1994 and 1995 XL models. Installing the 3/8-24 x 1-1/4 in. screws from kit will damage nut plate and screw threads.

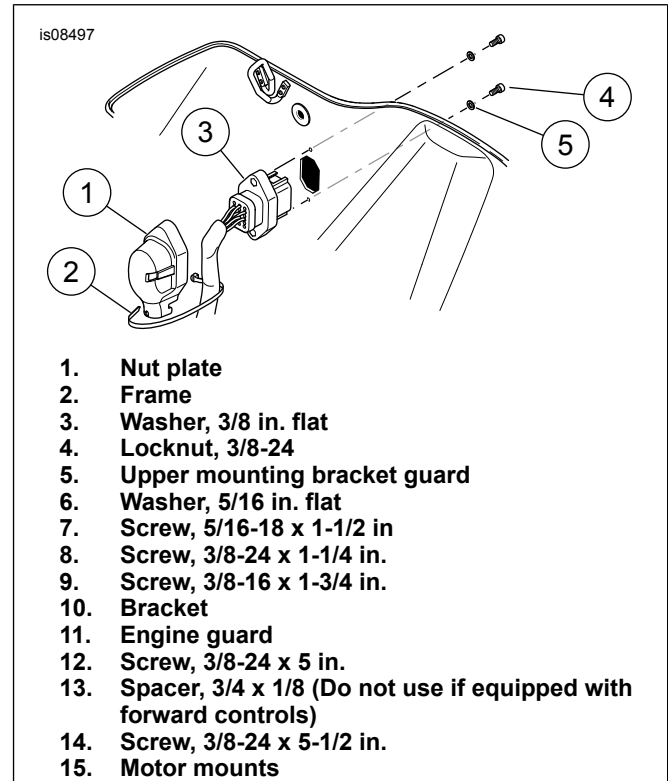

Figure 1. Disassembly/Installation (Alternator Models)

1. See Figure 1. From underside of steering head remove screws (7, 8, or 9) and flat washer (6). Discard original screws and washer.
2. Remove and discard the two top motor mount screws, washers, and nuts.
3. See Figure 1 and Figure 2. Place washer (3) on 5-1/2 in. long screw (14). Insert screw (14) through one motor mount, through spacer (13) (unless engine guard is being installed on a vehicle equipped with forward controls, in which case DO NOT USE SPACER), through the offset end of bracket (10), and (with large offset toward jiffy stand side of vehicle) through the other motor mount. Place kit supplied washer (3) on end of screw (14) and secure with locknut (4). Be sure bracket does not pinch wiring. On 1986 and later models be sure bracket does not contact oil pressure switch.
4. See Figure 1. Position engine guard (11) upper mounting bracket under the steering head.



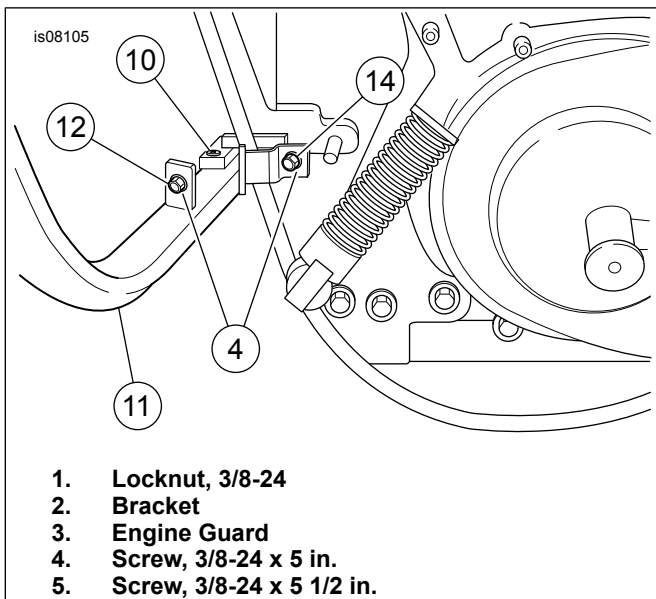

Figure 2. Hardware Positions - Late 1984 and Later Models

5. Place flat washers (6) on screws (7, 8, or 9):
 - a. Use 5/16-18 x 1-1/2 in. screws (7) and 5/16 in. washers (6) from kit on 1985 and earlier models.
 - b. Use 3/8-24 x 1-1/4 in. screws (8) and 5/16 in. washers (6) from kit on 1986 through early 1994 models.
 - c. On late 1994 and later models, reuse the stock 3/8-16 x 1-1/4 in. screws and washers.
 - d. Use 3/8-16 x 1-3/4 in. screws (9) and 5/16 in. washers (6) from kit on 1996 and later XL 883 models.
6. Insert screws (7, 8, or 9) through upper bracket on engine guard (11) and thread into nut plate.
7. Attach bracket (10) to engine guard (11) using screw (12) and locknut (4).
8. Tighten nut (4) on screw (12) to 33 ft-lbs.
9. Tighten screw (7, 8, or 9) to 19 ft-lbs.
10. Tighten nut (4) on screw (14) to 33 ft-lbs.
11. On 1986 models, remove clutch cable from clutch hand lever and route cable through engine guard. Install cable at hand lever and adjust freeplay according to procedure outlined in the 1986 XLH Service Manual.
12. Turn handlebars fully to the right and left and check for interference of clutch and brake cables from engine guard.

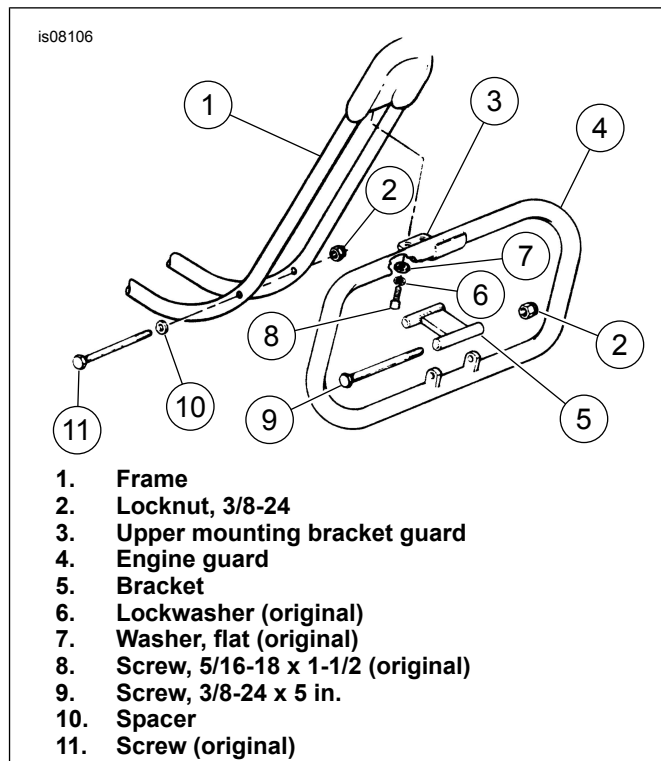

Figure 3. Installation (Generator Models)

Installation - 1982 to Early 1984 XL and XR-1000 Models (Equipped with Generator)

NOTE

Cover front fender with a clean rag to protect it from scratches during installation procedures.

1. See Figure 3. Remove screws (8), lockwashers (6), and flat washers (6) from underside of steering head. Discard original screws (7). Retain washers for reassembly. Do not remove shim washers between frame and motor bracket.
2. Remove screw (11), spacer (10), and nut (2) at frame downtubes.
3. Attach bracket (5), Part number 49014-85, to engine guard (4) using screw (9) and locknut (2). Tighten screw (9) to 33 ft-lbs (44.7 Nm).
4. Position engine guard (3) upper mounting bracket under steering head, with bracket (4) aligned with holes in frame downtube. Place original lockwashers (6) and flat washers (7) on screws (8). Insert screws (8) through upper engine guard bracket, through upper engine mount, and thread into tapped holes in steering head.
5. Insert original screw (11) through frame downtubes and bracket (5). Place new locknut (2) on screw (11) and tighten to 33 ft-lbs (44.7 Nm).
6. Tighten screws (8) to 19 ft-lbs (25.7 Nm).

Service Parts

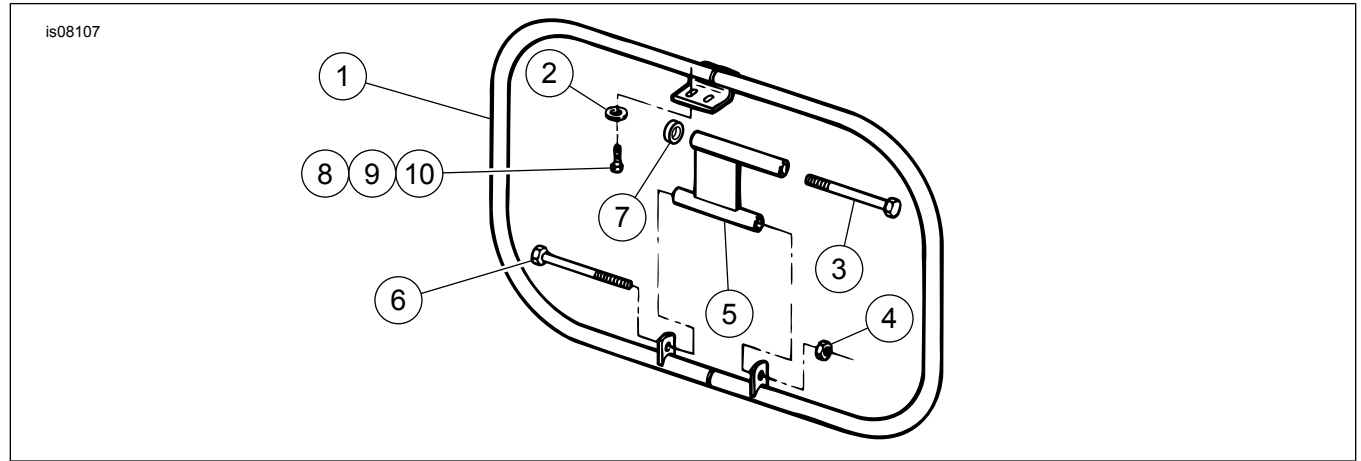

Figure 4. Service Parts

Table 1. Service Parts

Item	Description (Quantity)	Part Number
1	Engine guard	
2	Washer, 5/16 x 15/16 x 3/16 (2)	6336B
3	Screw, 3/8-24 x 5-1/2 in.	4413
4	Locknut, 3/8-24 x 7/16 x 9/16	7775
5	Bracket	49014-86A
6	Screw, 3/8-24 x 5 in.	4333
7	Spacer, 3/4 x 1/8	5789
8	Screw, 5/16-18 x 1-1/2 in. (2)	4816A
9	Screw, 5/16-24 x 1-1/4 in. (2)	45999-81A
10	Screw, 3/8-16 x 1-3/4 in. (2)	3554
11	Washer, 3/8 x 13/16 x 5/32 (Not Shown)	6474