



INSTRUCTIONS

J02924

2007-01-11



SADDLEBAG SUPPORT (DRESSER BAR) KIT CHROME

GENERAL

Kit Number

46565-04

Models

For model fitment information, please see the P&A Retail Catalog or the Parts and Accessories section of www.harley-davidson.com (English only).

Additional Parts Required

⚠ WARNING

Rider and passenger safety depend upon the correct installation of this kit. Use the appropriate service manual procedures. If the procedure is not within your capabilities or you do not have the correct tools, have a Harley-Davidson dealer perform the installation. Improper installation of this kit could result in death or serious injury. (00333b)

NOTE

This instruction sheet references Service Manual information. A Service Manual for your model motorcycle is required for this installation and is available from a Harley-Davidson Dealer.

Kit Contents

See Figure 1 and Table 1.

INSTALLATION

⚠ WARNING

To prevent accidental vehicle start-up, which could cause death or serious injury, disconnect negative (-) battery cable before proceeding. (00048a)

1. Refer to the Service Manual and follow the instructions to remove the seat and disconnect the negative battery cable.
2. Remove the saddlebags. Refer to SADDLEBAG REMOVAL in the Service Manual.

NOTE

See Figure 1. Item 12 covers saddlebag side rails, front guard and lower support removal for FLHT/C/CI/CUI, FLTR/I, FLHR/C and FLHR/II/CI models and item 13 cover removal for lower saddlebag support and front guard for FLHR/II/CI models.

3. See Figure 1. Gently pull one side cover (1) from the frame downtubes (no tools are required).

4. Remove the 5/16-18 hex head screws (not shown) and lockwashers (not shown) that secure the muffler to the muffler support (2). Save the muffler mount bracket, rubber mount from the old saddlebag lower support, 5/16-18 hex head screws and lockwashers.
5. With a T-40 TORX[®] driver, remove and discard the outside 5/16-18 TORX pan head screw (3) and 5/16-18 locknut (4) that secure the lower saddlebag support to the rear bumper and fender support.
6. Remove and discard the inside 5/16-18 locknut (5). Leave in, the inside 5/16-18 TORX pan head screw (6), to keep alignment of the rear bumper rail to the rear bumper and fender support.
7. With a T-40 TORX driver, remove and discard 5/16-18 TORX pan head screws (7) that secure the horizontal side rail saddlebag guards to the fender mounting support.
8. With a T-40 TORX driver, remove and discard the 3/8-16 TORX pan head screw (8) and 3/8-16 locknut (9) that fastens the lower flange of the front saddlebag guard to the motorcycle frame.
9. With a T-40 TORX driver, remove and discard the 3/8-16 TORX pan head screw (10) that fastens the upper flange of the front saddlebag guard to the frame. Remove the saddlebag guard with the rails and discard.
10. Repeat Steps 3 through 9 for the opposite side.
11. See Figure 2. The new chrome saddlebag supports are side-specific. Take the chrome left (1) (not shown) or right (2) side support from the kit and place it in position on the vehicle frame. Insert a 3/8-16 x 7/8 in long TORX pan head screw (5) and 3/8-16 locknut (6) from the kit through the front flange of the new support and into the vertical frame tube. Do not tighten the screw at this time.
12. Obtain the 5/16-18 x 1 in long TORX hex socket screw (3) and 5/16-18 locknut (4) from the kit. Insert screw through the outside hole (A) mounting tab on bumper and fender bracket and also through rear flange in new support and thread locknut onto screw and finger tighten.
13. See Figure 1. Remove old screw (6) from the inside hole of bracket. See Figure 2. From the kit, insert new 5/16-18 screw (4) into the inside hole (B) of bracket and thread locknut (5) on screw.
14. Tighten the front screw, then the rear screws and locknuts to 20.3–27.1 N·m (15–20 ft·lbs).



15. Install the muffler mount bracket and rubber mount saved from Step 4, into the new lower chrome support bracket (8).
16. Secure the muffler to the new chrome support bracket (8) with 5/16-18 hex head screws and 5/16 lockwashers (not shown) saved from Step 4.
17. Tighten the screws and locknuts to 20.3–27.1 N·m (15–20 ft-lbs).
18. Repeat Steps 11 through 16 for the opposite side.
19. Figure 1. Align the barbed studs in the side covers (1) with the grommets (11) in the frame downtubes and push firmly into place (no tools are required).

20. Install the saddlebags. Refer to SADDLEBAG INSTALLATION in the Service Manual.

21. Reconnect the negative (-) battery cable to the battery.

▲ WARNING

After installing seat, pull upward on seat to be sure it is locked in position. While riding, a loose seat can shift causing loss of control, which could result in death or serious injury. (00070b)

22. Refer to the Service Manual and follow instructions to install the seat.

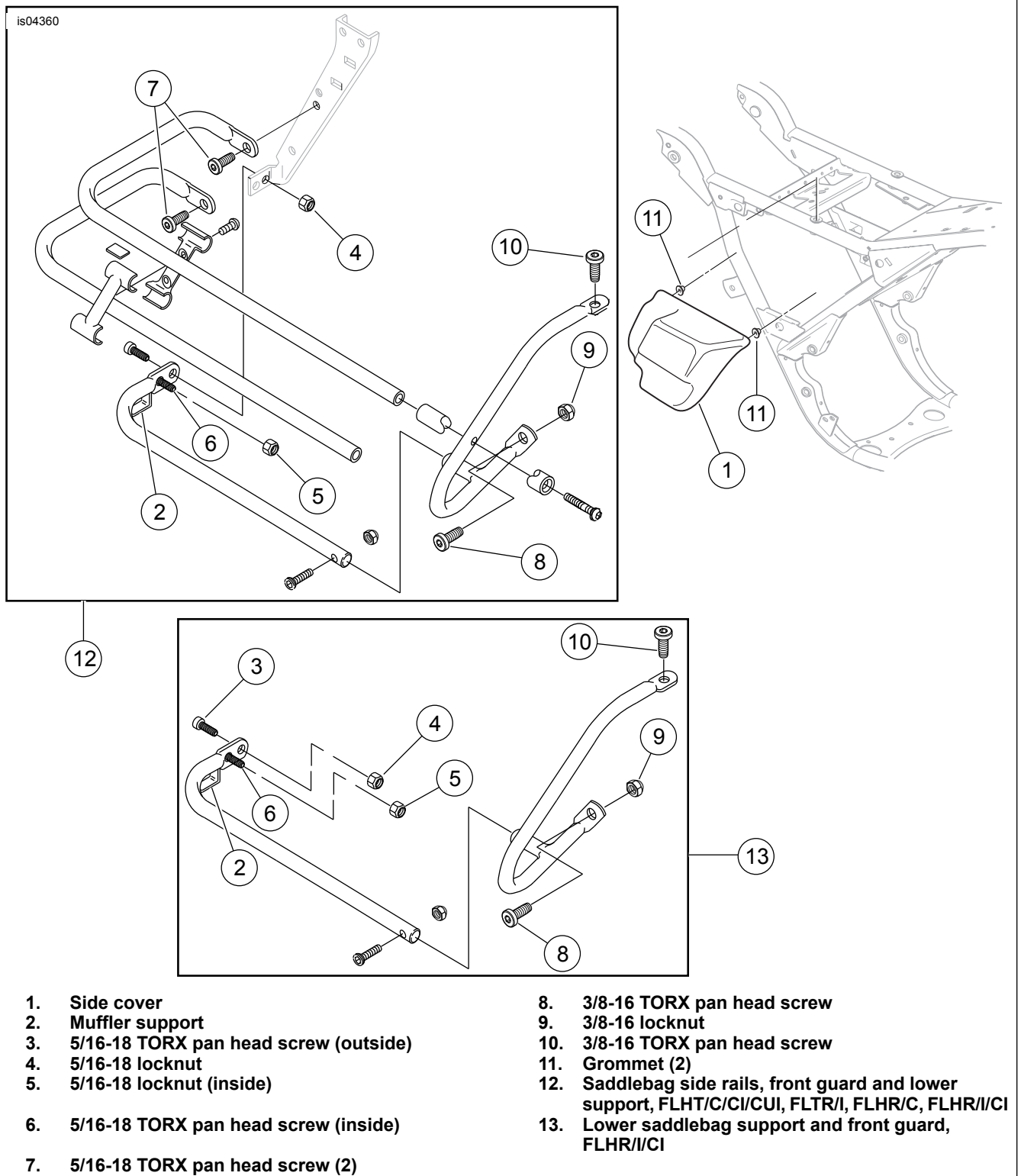

Figure 1. Saddlebag Support Removal Procedure

SERVICE PARTS

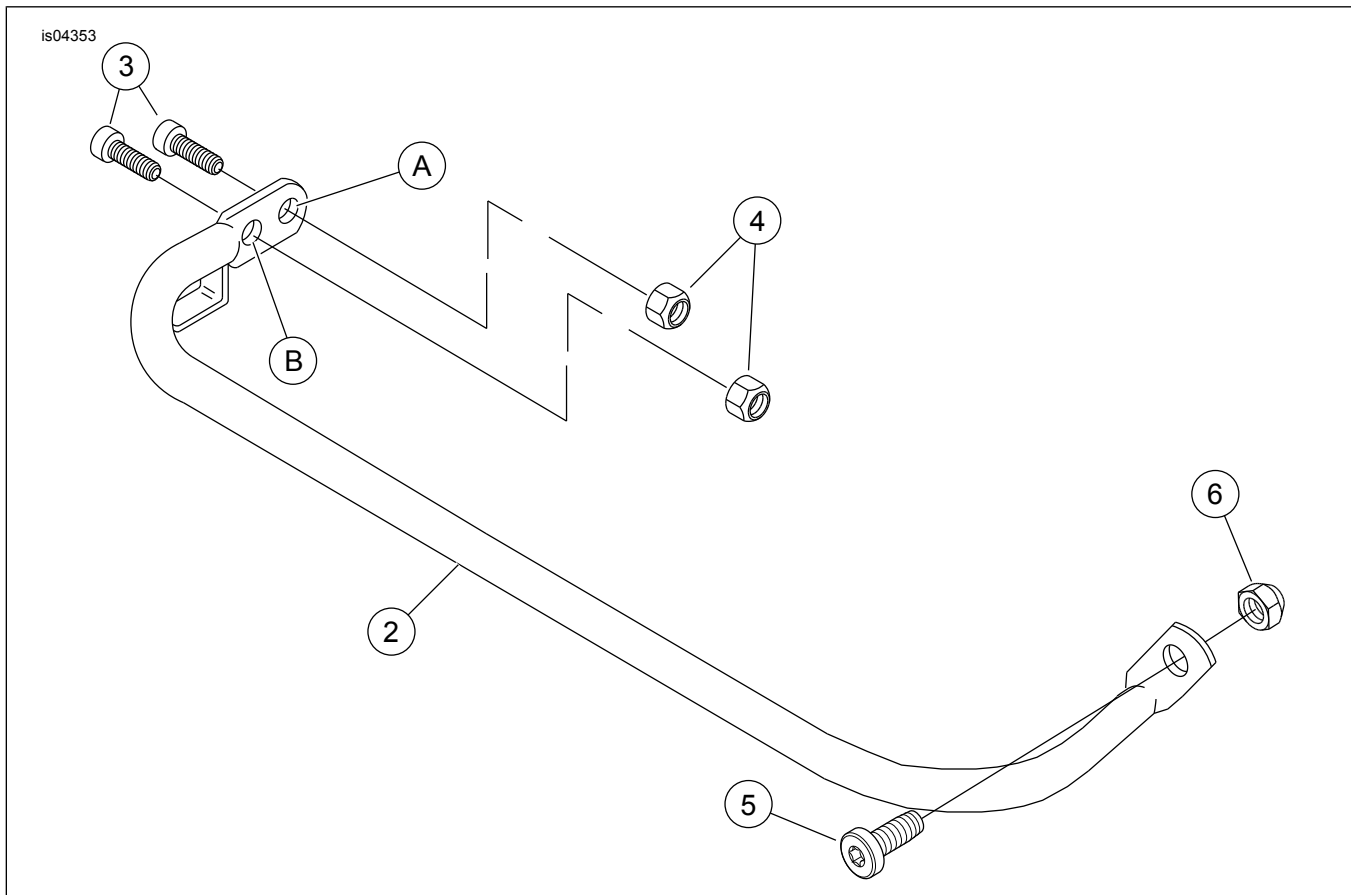

Figure 2. Service Parts: Saddlebag Support (Dresser Bar) Kit, Chrome

Table 1. Service Parts Table

Item	Description (Quantity)	Part Number
1	Left side bracket (chrome) (Not shown)	49206-04
2	Right side bracket (chrome)	49207-04
3	Screw, pan head, 5/16-18 x 1.0 inch (4)	3684
4	Nut, locking flange, 5/16-18 (4)	7531
5	Screw, pan head, 3/8-16 x 7/8 inch (2)	3678
6	Locknut, 3/8-16 (2)	7667
Items mentioned in text:		
A	Outside screw hole	
B	Inside screw hole	