



INSTRUCTIONS

J03567

2005-06-07



DYNA CHROME SHORTEE BELT GUARD

GENERAL

Kit Number

60322-04

Models

This kit is designed to fit 2006 Dyna model motorcycles. See the Service Parts illustration for kit contents.

⚠ WARNING

Rider and passenger safety depend upon the correct installation of this kit. Use the appropriate service manual procedures. If the procedure is not within your capabilities or you do not have the correct tools, have a Harley-Davidson dealer perform the installation. Improper installation of this kit could result in death or serious injury. (00333b)

NOTE

This instruction sheet references Service Manual information. A Service Manual for your model motorcycle is required for this installation and is available from a Harley-Davidson Dealer.

Kit Contents

See Figure 1 and Table 1.

Belt Guard Removal

See the appropriate Service Manual for original equipment belt guard removal procedure.

NOTE

Retain two spacers and rubber grommets from original equipment belt guard for installation of new belt guard.

Installation

1. Install previously removed spacer and grommets on new belt guard.
2. See Service Parts illustration. Place belt guard (1) over front and rear tabs on swing arm.
3. Install hex socket button head cap screw (5) with two chrome plated washers (2) and chrome cap nut (4) to front of belt guard.
4. Install hex socket button head cap screw (3) with chrome plated washer (2) and chrome cap nut (4) to rear of belt guard.
5. Tighten hardware to 120-180 **in-lbs** (13.6-20.3 Nm).

⚠ WARNING

Failure to provide adequate clearance between stationary and moving parts can cause loss of control, which could result in death or serious injury. (00378a)

6. Verify that the belt guard does not contact belt during rear fork travel.

SERVICE PARTS

See Figure 1 and Table 1.



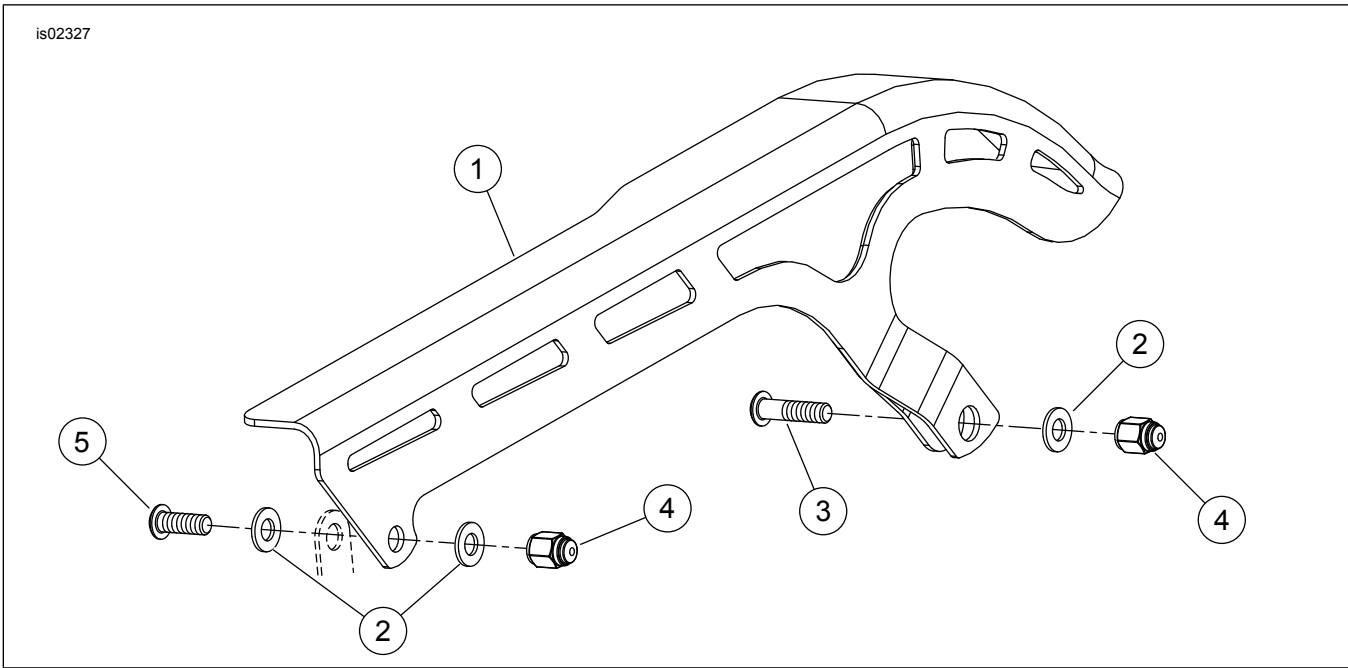

Figure 1. Service Parts: Dyna Chrome Shortee Belt Guard

Table 1. Service Parts Table

Item	Description (Quantity)	Part Number
1	Beltguard, shortee assembly	Not sold
2	Washer, plain type A, chrome plated, (3)	6330
3	Capscrew, hex socket button head	4007
4	Nut, chrome cap (2)	8024
5	Capscrew, hex socket button head	4359