



INSTRUCTIONS

J02938

2015-04-09



DOCKING HARDWARE FOR XL WITH SADDLEBAGS

GENERAL

Kit Number

53544-04

Models

For model fitment information see the P&A Retail Catalog or the Parts and Accessories section of www.harley-davidson.com (English only).

Kit Contents

See Figure 2 and Table 1.

NOTE

This instruction sheet references Service Manual information. A Service Manual for your model motorcycle is required for this installation and is available from a Harley-Davidson dealer.

REMOVAL

1. **For 883 and 1200 Roadster Models:** Secure the motorcycle upright, then lift the rear of the vehicle to provide clearance between the rear tire and fender for access to the fender hardware.
2. **For All Other Models:** Refer to REAR SHOCK ABSORBER, REMOVAL in the Service Manual for removal of the upper shock mounting screw. Lower the rear wheel to provide clearance between the rear tire and fender for access to the fender hardware.

NOTE

Complete the following procedures on one side of the motorcycle before starting the other side.

3. Relocate the turn signals per the instructions furnished in the saddlebag instruction kit.
4. See Figure 1. Remove and discard the front screw (3) and locknut (1) from the rear fender support cover (2).
5. Remove and discard the rear screw (4) and clip nut (5) from the rear fender support cover.

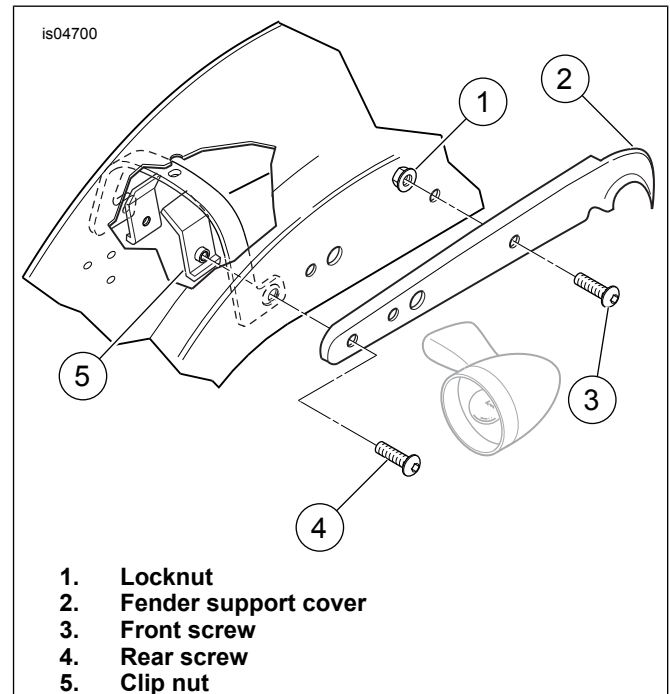

Figure 1. Rear Fender Support (Right Side Shown)

INSTALLATION

Front Hole

1. **For 88312-07 and 90201325 Saddlebag Kits:** See Figure 2. Obtain a front docking point (2), cap screw (1) and spacer (F) from kit. Note the small-diameter collar on one end of the docking point. From the underside of the fender, insert the screw through the forward hole in the fender, and through the fender support and cover. Place the docking point onto the screw threads, collar end first. Place the front docking point spacer onto the screw threads as shown. **For 90201321 Saddlebag Kit:** See Figure 2. Obtain a front docking point (2), cap screw (1) and spacer (C) from kit. Note the small-diameter collar on one end of the docking point. From the underside of the fender, insert the screw through the forward hole in the fender, and through the fender support and cover. Place the docking point onto the screw threads, collar end first. Place the front docking point spacer onto the screw threads as shown, with the short end facing out.



2. **For All Other Saddlebag Kits:** See Figure 2. Obtain a front docking point (2), cap screw (1) and spacer (5) from kit. Note the small-diameter collar on one end of the docking point. From the underside of the fender, insert the screw through the forward hole in the fender, and through the fender support and cover. Place the docking point onto the screw threads, collar end first. Place the spacer onto the screw threads. Place the front docking point spacer (5) onto the screw threads as shown, with the short end facing out.

Rear Hole

1. **For 88312-07 and 90201325 Saddlebag Kits:** Obtain a rear docking point (3) and cap screw (1) from the kit and spacer (E). Note the small-diameter collar on one end of the docking point. From the underside of the fender, insert the screw through the rearmost hole in the fender and through the fender support and cover. Place the docking point onto the screw threads, collar end first. Place the spacer onto the screw threads. **For 90201321 Saddlebag Kit:** Obtain a rear docking point (3) and cap screw (1) from the kit and spacer (D). Note the small-diameter collar on one end of the docking point. From the underside of the fender, insert the screw through the rearmost hole in the fender and through the fender support and cover, with the short end facing out. Place the docking point onto the screw threads, collar end first. Place the spacer onto the screw threads.

2. **For All Other Saddlebag Kits:** Obtain a rear docking point (3) and cap screw (1) from the kit. Note the small-diameter collar on one end of the docking point. From the underside of the fender, insert the screw through the rearmost hole in the fender and through the fender support and cover. Place the docking point onto the screw threads, collar end first.
3. Obtain the correct side saddlebag from the saddlebag kit. Slide the saddlebag onto the screws until the bushings are seated into the saddlebag support (A) and or spacers are up against saddlebag support (A).
4. Thread the locknuts (4) onto the screws from inside the saddlebag. Tighten both nuts to 35–40 N·m (26–29 ft-lbs).
5. Install a thread protector (B) onto the threaded end of each screw.

Repeat all steps for the other side.

Maintenance

NOTE

In time, the docking points may wear causing the mating accessory to become loose. The fit may be tightened using the following procedure.

1. Loosen the docking hardware.
2. Rotate the docking points clockwise approximately 45°.
3. Tighten the docking hardware to the appropriate torque values as indicated in the installation procedures.
4. This procedure can be repeated up to 3 times before replacement of the docking points is recommended.

SERVICE PARTS

is04701b

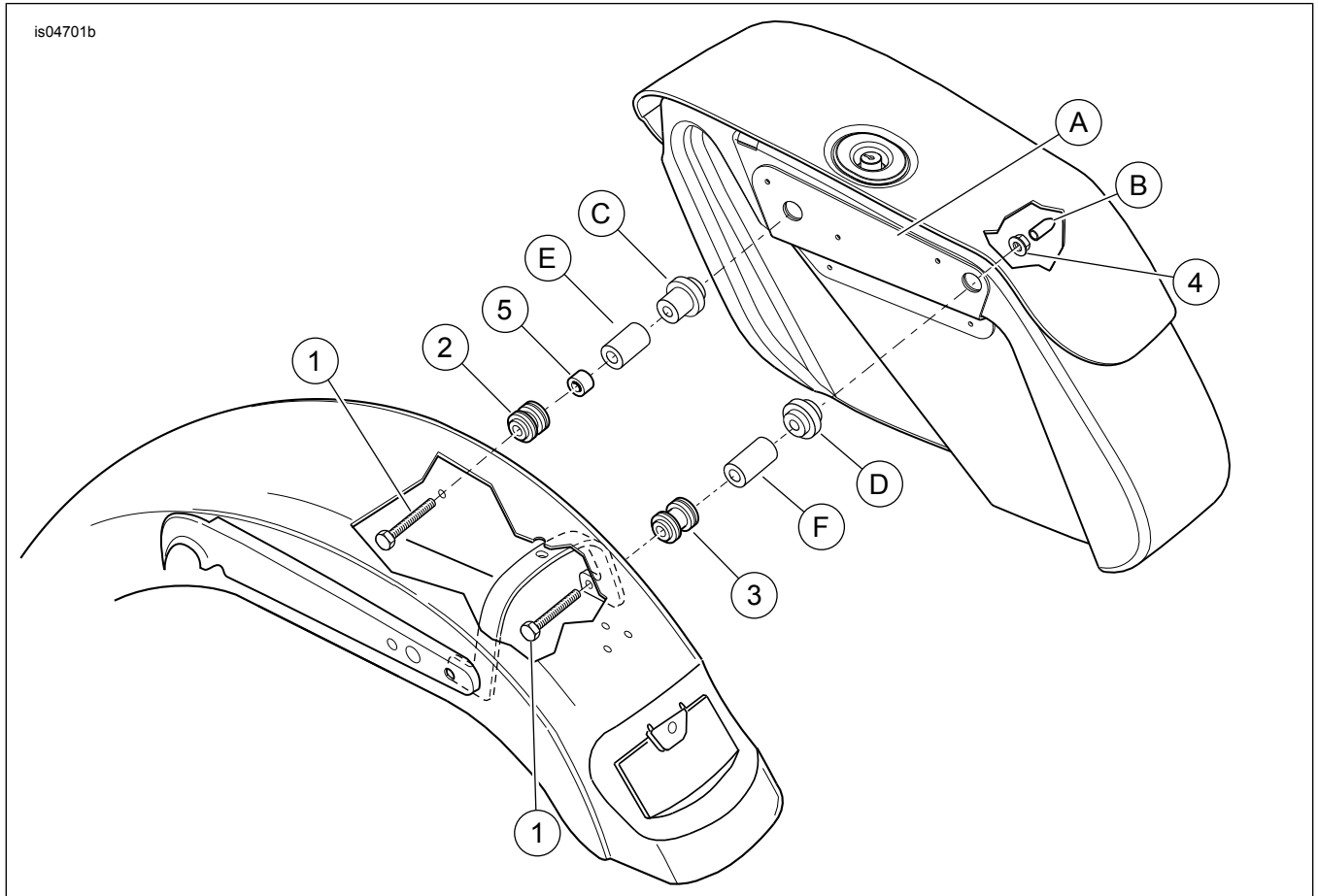

Figure 2. Service Parts: Docking Hardware, Sportster with Saddlebags

Table 1. Service Parts: Docking Hardware, Sportster with Saddlebags

Item	Description (Quantity)	Part Number
1	Cap screw, hex head, 5/16-18 x 3-3/4 in (4)	4298
2	Docking point, front (2)	53942-04
3	Docking point, rear (2)	53943-04
4	Locknut, flanged 5/16-18 (4)	7531
5	Spacer, front docking point	Not Sold Separately
Item mentioned in text, but not included in kit:		
A	Saddlebag support (included with saddlebag kit)	Not Sold Separately
B	Thread protector (included with saddlebag kit)	Not Sold Separately
C	Bushing, long (2) (from Kit 90201321)	53021-04A
D	Bushing, short (2) (from Kit 90201321)	53022-04A
E	Spacer 1.2 in long (from Kit 90201325)	12400114
F	Spacer 1.4 in long (from Kit 90201325)	12400115