



# INSTRUCTIONS

J01701

2007-09-27



## FLT REAR MASTER CYLINDER COVER KIT

### GENERAL

#### Kit Number

45318-99

#### Models

For model fitment information, please see the P&A Retail Catalog or the Parts and Accessories section of [www.harley-davidson.com](http://www.harley-davidson.com) (English only).

#### Kit Contents

See Figure 2 and Table 1.

### INSTALLATION

1. See Figure 2. Using screw (5) and washer (4), loosely install bracket (3) to cover (2). Finger tighten.
2. See Figure 1. Remove TORX® T40 screw from lower engine guard at location shown.
3. Slip master cylinder cover over master cylinder and align hole in bracket with hole in engine guard.
4. Install TORX T40 screw through cover bracket and engine guard and tighten to 16.3–20.3 N·m (12–15 ft-lbs).
5. Tighten master cylinder cover screw (5) securely.

### SERVICE PARTS

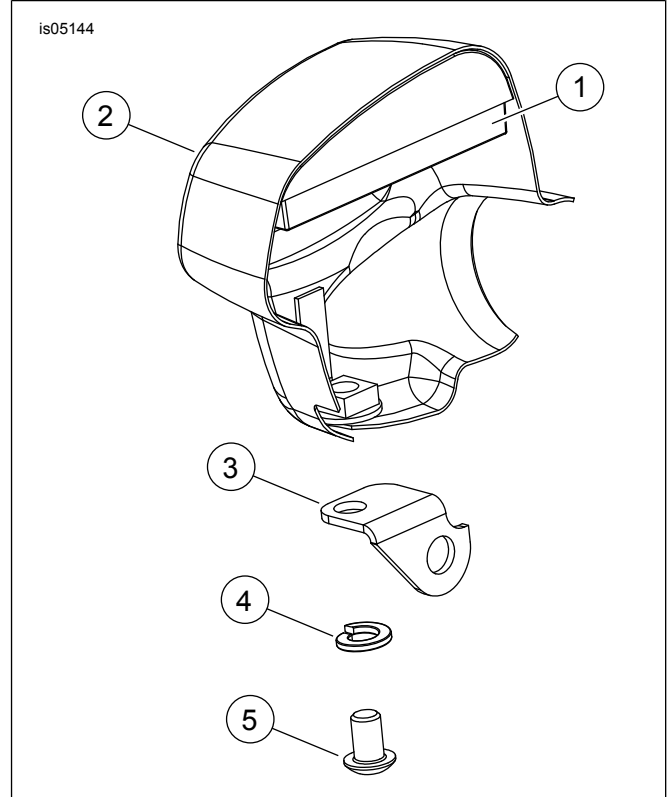
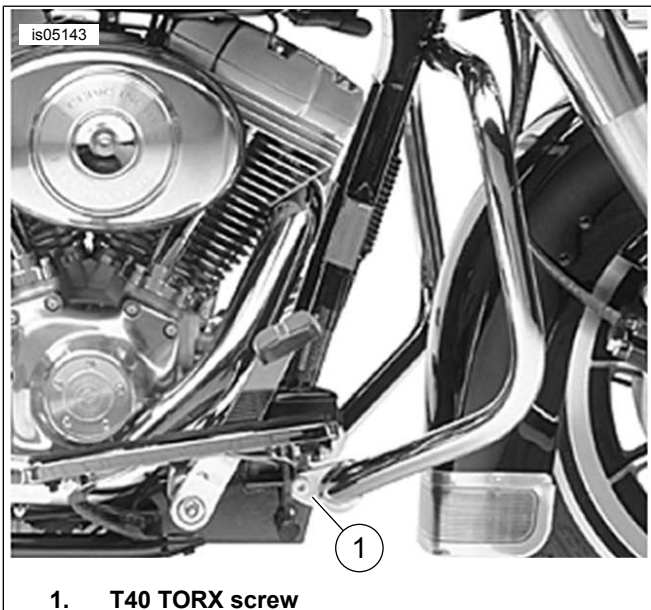

Figure 2. Service Parts: Master Cylinder Cover Kit

Table 1. Service Parts: Master Cylinder Cover Kit

Item	Description (Quantity)	Part Number
1	Cover pad	Not Sold Separately
2	Master cylinder cover	Not Sold Separately
3	Mounting bracket	Not Sold Separately
4	Lockwasher, spring	94081-90T
5	Button head screw	94396-92T



1. T40 TORX screw

Figure 1. Lower Engine Guard TORX Screw