



INSTRUCTIONS

J01702

2006-08-04



XL DOCKING HARDWARE/DIRECTIONAL RELOCATION KIT

GENERAL

Kit Number

90465-98A

Models

For the most up-to-date model fitment information, please see product label or www.harley-davidson.com.

This kit will not fit models equipped with Flat Lens Turn Signals (68431-95) or Bullet Style Turn Signals (68005-99 or 68637-99).

Installation of this kit is required when installing Detachable Sideplates (53545-95 or 53609-01) or a Detachable Solo Rack (53495-95) with Leather Saddlebags (90598-04 or 90342-04).

Additional Parts Required

⚠ WARNING

Rider and passenger safety depend upon the correct installation of this kit. Use the appropriate service manual procedures. If the procedure is not within your capabilities or you do not have the correct tools, have a Harley-Davidson dealer perform the installation. Improper installation of this kit could result in death or serious injury. (00333b)

NOTE

This instruction sheet references Service Manual information. A Service Manual for your model motorcycle is required for this installation and is available from a Harley-Davidson Dealer.

Kit Contents

See Figure 2 and Table 1.

INSTALLATION

- See Figure 2. Following directions supplied with saddlebags to relocate rear turn signals, but also use the following exceptions to install the parts contained in this kit:
 - Use turn signal studs (4) in place of hex bolts supplied with saddlebags. The longer studs are required to accommodate the rear docking points.
 - On each side, insert relocation pad plate (3), saddlebag mount spacer (12), rear docking point (2), and docking point spacer (11) between relocation pad (supplied with saddlebags), and fender support cover as shown.
 - Use 4-inch long cap screw (5) in place of hex bolts supplied with saddlebags. The longer cap screws are required to accommodate the rear docking points.
 - The turn signal wires should be routed under the fender support cover back to the connectors they were removed from following the directions supplied with saddlebags.

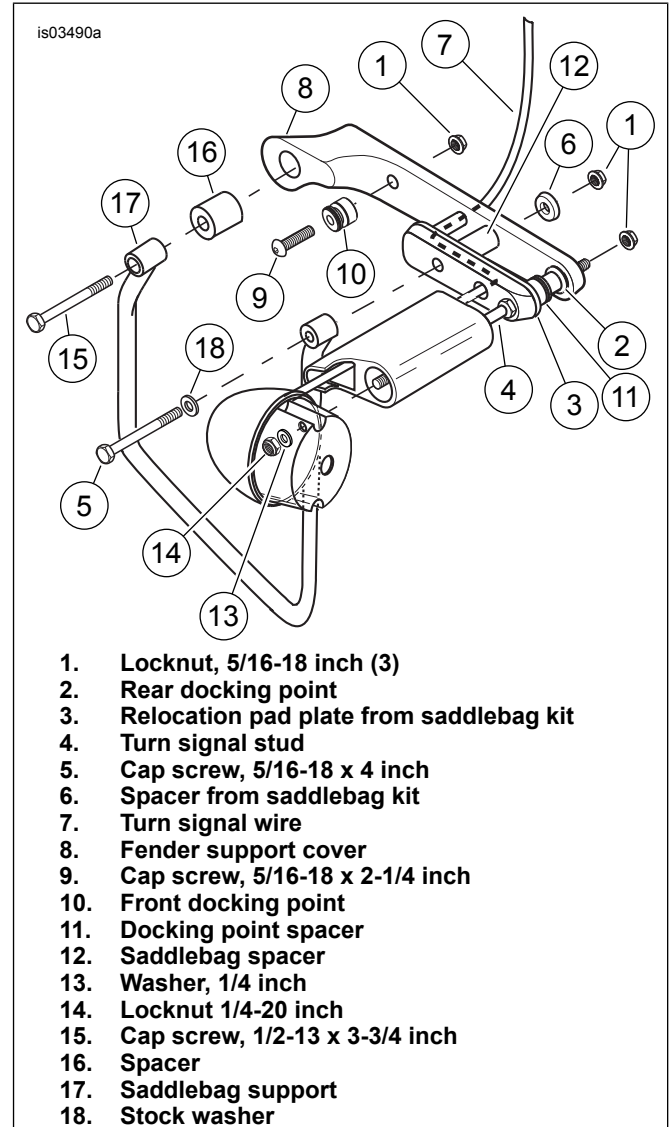

Figure 1. Installation shown on 2000 model

On 1999 and earlier models:

See Figure 2. Before mounting saddlebag supports, remove acorn nut from upper shock mount, and install washer (7), and shock mount spacer (8) as shown. Tighten upper shock mount spacer to 21-35 ft-lbs (28-47 Nm). This will properly space out the saddlebags to accommodate the docking points.

On 2000 models:

See Figure 1. Before mounting saddlebag supports remove button screw from upper stock mounts, and proceed to Step 2.

NOTE

If a weldnut exists in the rearward locknut (1) location, do not use the locknut.

2. Mount front docking points with button head screws (9), and locknuts (1) as shown in Figure 2. Tighten locknuts to 8-10 ft-lbs (11-14 Nm).

3. **On 1999 and earlier models:** Mount saddlebag support following directions supplied in saddlebag kit and install saddlebags. **On 2000 models:** See Figure 1. Install saddlebag support according to directions supplied in saddlebag kit making sure to use the spacer (16), and screw (15) supplied in this kit.

NOTE

To avoid personal injury be sure to read all warnings included in the instructions supplied with your saddlebag kit. If you have discarded the instructions supplied with your saddlebag kit, your Harley-Davidson dealer can supply you with another copy.

SERVICE PARTS

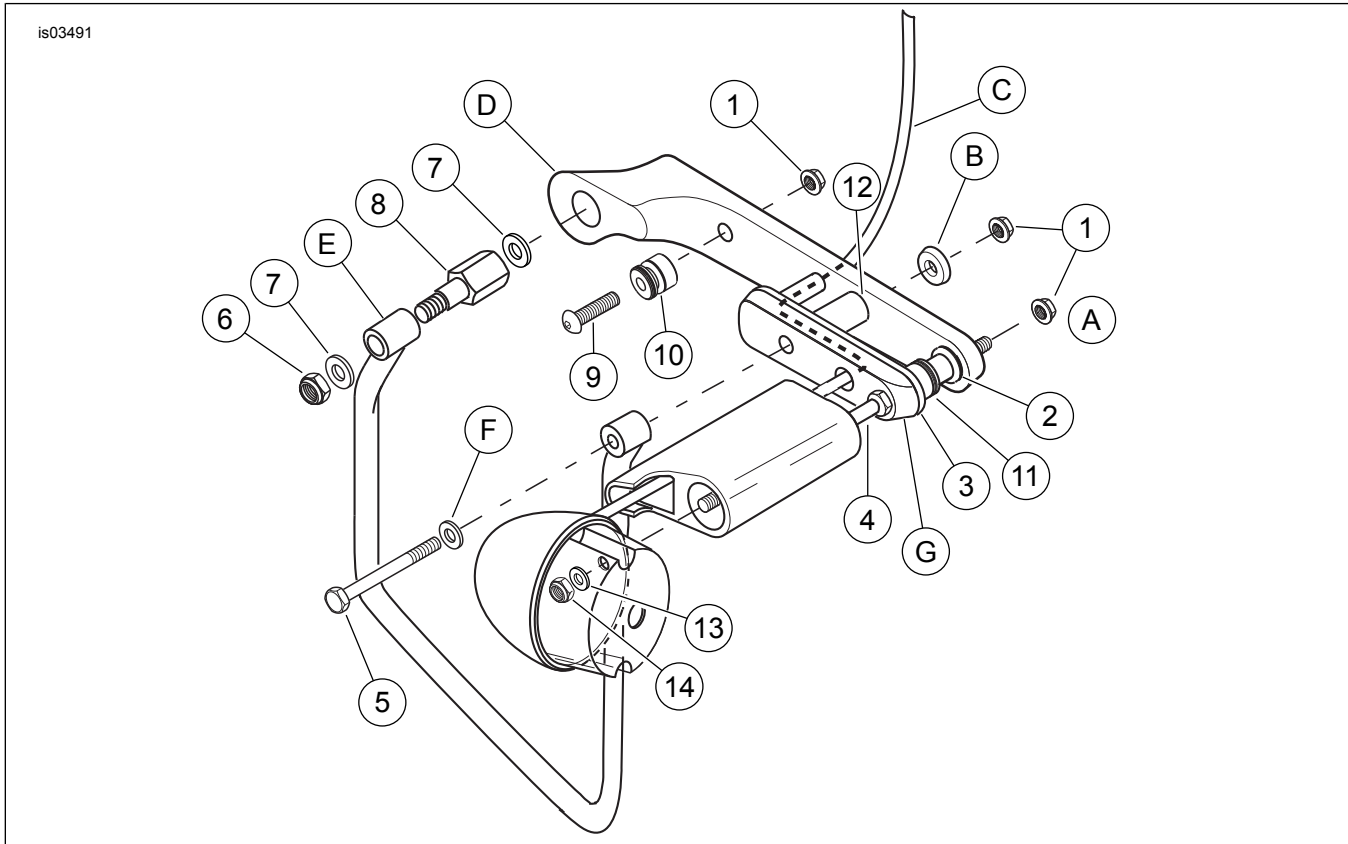

Figure 2. Service Parts: XL Docking Hardware/Directional Relocation Kit

Table 1. Service Parts Table

Item	Description (Quantity)	Part Number	Item	Description (Quantity)	Part Number
1	Locknuts (6) 5/16-18	7531	9	Capscrew (2), buttonhead, 5/16-18 x 2-1/4 in. long	4184
2	Rear docking points (2)	53686-96A	10	Front docking points (2)	53685-96
3	Relocation pad plates (2)	59681-98	11	Docking point spacers (2)	53775-98
4	Turn signal studs (2)	90466-98	12	Saddlebag mount spacers (2)	53776-98
5	Capscrews (2), buttonhead, 5/16-18 x 4 in. long	4100HW	13	Washers (2), 1/4	6703
*6	Locknuts (2), 3/8-16	7778	14	Locknuts (2) 1/4-20	7686
*7	Washers (4), 3/8	6701	*15	Capscrews (2), 1/2-13 x 3 3/4	3829
*8	Shock mount spacers (2)	90506-98	*16	Spacers	53847-00
*Item numbers 6, 7, and 8 are for installation on 1999 and earlier models. Items 15 and 16 are for installation on 2000 models (See Figure 1).					
A	Do not install this nut if your bike is equipped with a weld nut in the fender support weldment.				
B	Supplied in saddlebag kit, install between fender support cover and frame.				
C	Turn signal wire				
D	Fender support cover				
E	Saddlebag support				

Table 1. Service Parts Table

Item	Description (Quantity)	Part Num-ber	Item	Description (Quantity)	Part Number
F	Existing				
G	Supplied in saddlebag kit				