



# INSTRUCTIONS

J02681

2006-05-05



## FINNED DERBY COVER

### GENERAL

#### Kit Number

25454-01

#### Models

This kit fits 1999 and later Evolution 1340 and Twin Cam equipped models.

#### Additional Parts Required

Installation on 2006 and later Dyna, 2007 Softail, and 2007 Touring models requires separate purchase of Gasket, Part Number 25416-99C.

#### NOTE

A Service Manual for your model motorcycle is available from a Harley-Davidson Dealer.

#### Kit Contents

See Figure 2 and Table 1.

### INSTALLATION

For models equipped with left side exhaust pipe:

#### ▲ WARNING

Perform this installation when the engine is cool. Working on or near the exhaust system when the engine is hot could result in severe burns. (00311b)

#### NOTE

Remove clutch inspection (derby) cover with motorcycle upright, not on side stand. If cover is removed with motorcycle on side stand, primary fluid will leak out of primary chaincase.

1. On models so equipped, remove the **left-side** passenger footboard. Using a T27 TORX® drive head, remove the five screws with captive washers. Save screws and washers for installation.

#### NOTE

The gasket between the clutch inspection cover and the chaincase cover must be removed and all oil must be wiped from the gasket and groove in chaincase cover each time the cover is removed.

2. Remove the gasket from the groove in the chaincase cover and mounting surface.
3. Inspect gasket for tears or damage. Replace as required.

#### NOTE

If installing the Derby cover on 2006 and later Dyna, 2007 Softail, and 2007 Touring model, the original equipment gasket **must** be discarded and replaced with Derby Cover Gasket 25416-99C (sold separately).

4. To avoid punching holes in the clutch inspection cover gasket or enlarging the existing holes, install the new derby cover and gasket as follows:
  - a. Align the triangular shaped hole in the gasket with the top hole in the derby cover. Be sure the rubber molding and the words "towards clutch" face the motorcycle.
  - b. Install the gasket and derby cover on the primary chaincase cover using the screws and washers removed in Step 1. Place a washer onto the thread of one of the screws and insert the screw through the top hole in the derby cover, and carefully thread it all the way through the triangular shaped hole in the gasket. Do not push the screw through the hole.
  - c. Hang the derby cover on the primary chaincase cover flange by starting the top cover screw.
  - d. Start the remaining four screws and washers.
5. Install derby cover (1) and gasket on primary chaincase cover using screws and washers from the kit. Tighten screws to 10–12 N·m (84–108 in-lbs) in the sequence shown in Figure 1.

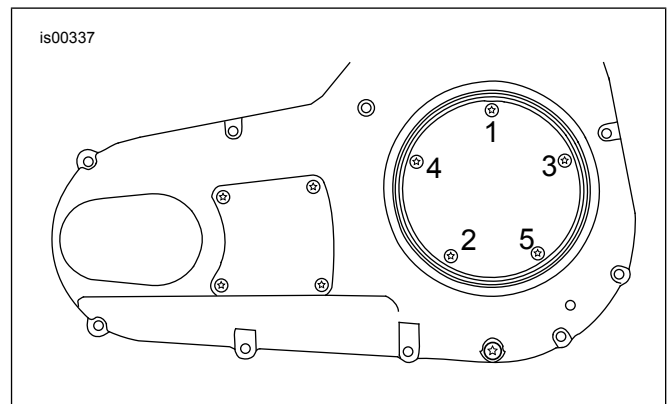

Figure 1. Torque Sequence, Clutch Inspection Cover

#### NOTE

Because the derby cover is new and some lightening of the original black finish on the engine may have occurred over time, use S100 Engine Restorer and Brightener (Part Number 99849-97) to improve the overall color match between the cover and engine. S100 Engine Restorer and Brightener is available at your Harley-Davidson Dealer.



# SERVICE PARTS

is00583

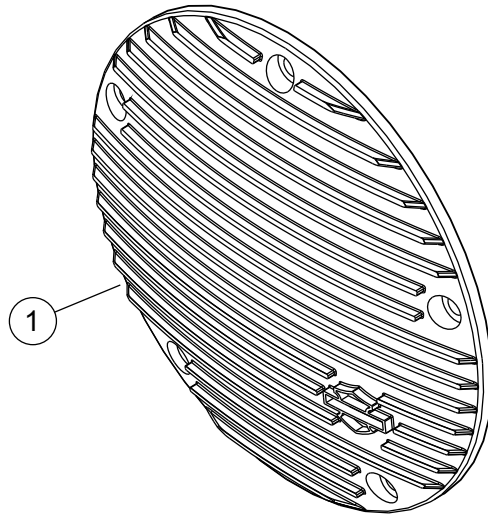

Figure 2. Service Parts: Finned Derby Cover

Table 1. Service Parts: Finned Derby Cover

Item	Description (Quantity)	Part Number
1	Derby cover, 5 hole	25454-01