



INSTRUCTIONS

J00662

2011-03-04



FLSTC DOCKING HARDWARE WITH SADDLEBAG SUPPORTS

GENERAL

Kit Number

53371-95B

Models

For model fitment information, see the P&A Retail Catalog or the Parts and Accessories section of www.harley-davidson.com (English only).

Additional Parts Required

The kit can be used with Softail Detachable Solo Racks or with Detachable Sissybar Sideplates. See the P&A Retail Catalog or the Parts and Accessories section of www.harley-davidson.com (English only) for a list of required parts or accessories for your model.

▲ WARNING

Rider and passenger safety depend upon the correct installation of this kit. Use the appropriate service manual procedures. If the procedure is not within your capabilities or you do not have the correct tools, have a Harley-Davidson dealer perform the installation. Improper installation of this kit could result in death or serious injury. (00333b)

Kit Contents

See Figure 2 and Table 1.

REMOVAL

NOTE

Perform the following procedures on one side of the motorcycle at a time until instructed to go to the other side.

Keep all hardware for later reassembly unless it is stated to discard it.

1. See Figure 1. Remove screws (1) and washers (2) from saddlebag support at three places. Remove saddlebag from saddlebag support.
2. Remove saddlebag support from lower front support assembly (5 or 11). On 1990 through 1993 model vehicles, remove bolt (13) and washer (12). On 1994 and later models, remove acorn nut (3) and washer (4).
3. Remove and discard screws (6). Remove washers (7). Remove saddlebag support from fender support.
4. Remove and discard locknuts (9), washers (10) and upper bushing supports (8) from fender support and fender.
5. Repeat steps 1 - 4 on other side of vehicle.
6. Remove and discard sissybar assembly.

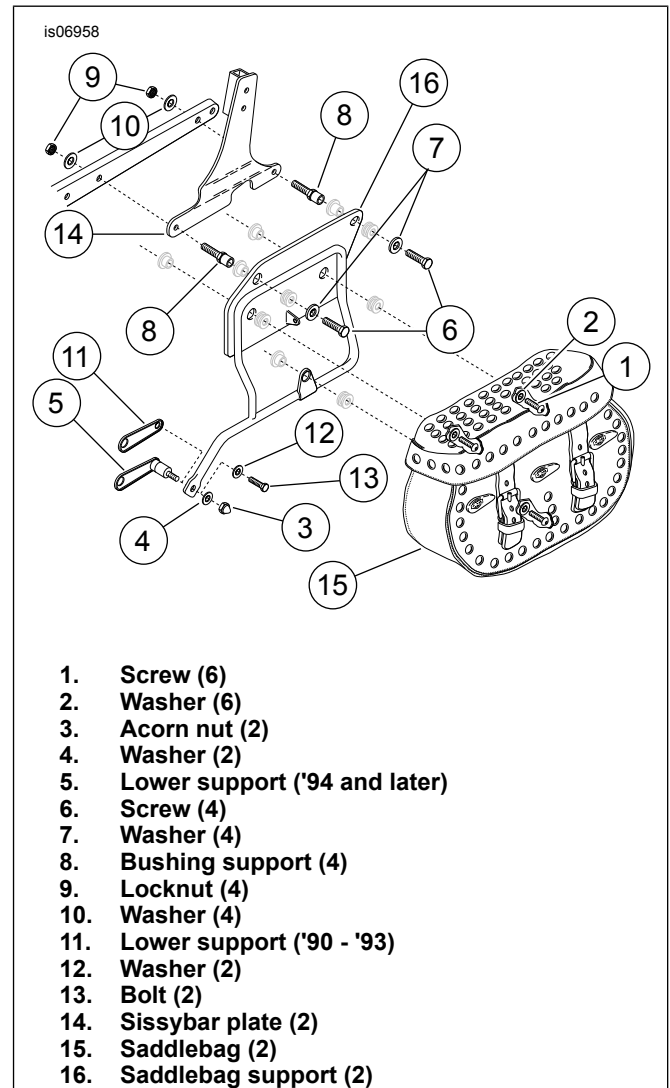

1. Screw (6)
2. Washer (6)
3. Acorn nut (2)
4. Washer (2)
5. Lower support ('94 and later)
6. Screw (4)
7. Washer (4)
8. Bushing support (4)
9. Locknut (4)
10. Washer (4)
11. Lower support ('90 - '93)
12. Washer (2)
13. Bolt (2)
14. Sissybar plate (2)
15. Saddlebag (2)
16. Saddlebag support (2)

Figure 1. Saddlebag/Sissybar Assembly (left side)

DOCKING HARDWARE INSTALLATION

NOTE

See Figure 2. The rear docking point (5) is wider than the front docking point (6).

1. See Figure 2. Install the front docking point (6) and rear docking point (5). For each docking point, place the countersunk side of the docking point so it faces towards the support cover. Insert the bushing support (2) through the docking point and into the fender, then install the washer (4) and locknut (3) on the inside of the fender. Torque the bushing supports (2) to 37 N-m (27 ft-lbs).
2. Repeat step 1 on other side of vehicle.



SADDLEBAG SUPPORT REATTACHMENT

NOTICE

Check that saddlebag frame(s) are fully seated and tightly secured with mounting hardware. Failure to do so could result in the saddlebags becoming detached and/or damaged. (00171b)

NOTE

The saddlebag supports are designed to project slightly outward from the side of motorcycle. Place saddlebag supports on the correct side of motorcycle or saddlebags may rub against rear wheel and adversely affect handling.

Verify that all grommets are in place in saddlebag support.

1. See Figure 2. Place stock washers removed in step 3, page 1, onto screws (1) from kit.
2. Place screws (1) through saddlebag support and thread screws into bushing supports (2). Tighten screws (1) to 20–26 N·m (15–19 ft-lbs).
3. See Figure 1. On 1990 through 1993 vehicles use washer (12) and bolt (13) retained in step 2 on page 1. Attach bottom part of saddlebag support to the lower support (11). Tighten bolt (13) to 22–27 N·m (16–20 ft-lbs). On 1994 and later vehicles use acorn nut (3) and washer (4) retained in step 2 on page 1. Attach the bottom part of the saddlebag support to the lower support (5). Tighten acorn nut (3) to 22–27 N·m (16–20 ft-lbs).
4. Repeat steps 1 - 3 on other saddlebag support.

SADDLEBAG REATTACHMENT

1. See Figure 1. Reattach left and right side saddlebags to saddlebag supports by reversing the Saddlebag Removal procedure on page 1.

2. Tighten screws (1) to 22–27 N·m (16–20 ft-lbs).

REFLECTOR REMOVAL, PLACEMENT AND INSTALLATION

⚠ WARNING

Federal Motor Vehicle Safety Standard (FMVSS) 108 requires motorcycles to be equipped with rear and side reflectors. Be sure rear and side reflectors are properly mounted. Poor visibility of rider to other motorists can result in death or serious injury. (00336b)

1. See Figure 2. Align round reflector with saddlebag. Mark reflector mounting position on saddlebag.
2. Drill a 3/16 in. hole in saddlebag at mounting mark.
3. Install screw (7) to reflector (8) and insert screw to saddlebag. From inside saddlebag install washer (10) and nut (11) and tighten as needed.
4. Repeat steps 1 - 3 on other saddlebag.

MAINTENANCE

1. In time docking points may wear, causing the mating luggage rack or sideplates to become loose. The fit may be tightened using the following procedure:
 - a. Loosen docking hardware.
 - b. Rotate docking points clockwise approximately 45 degrees.
 - c. Tighten docking hardware to the appropriate torque values.
2. Repeat as often as needed, up to 3 times.

SERVICE PARTS

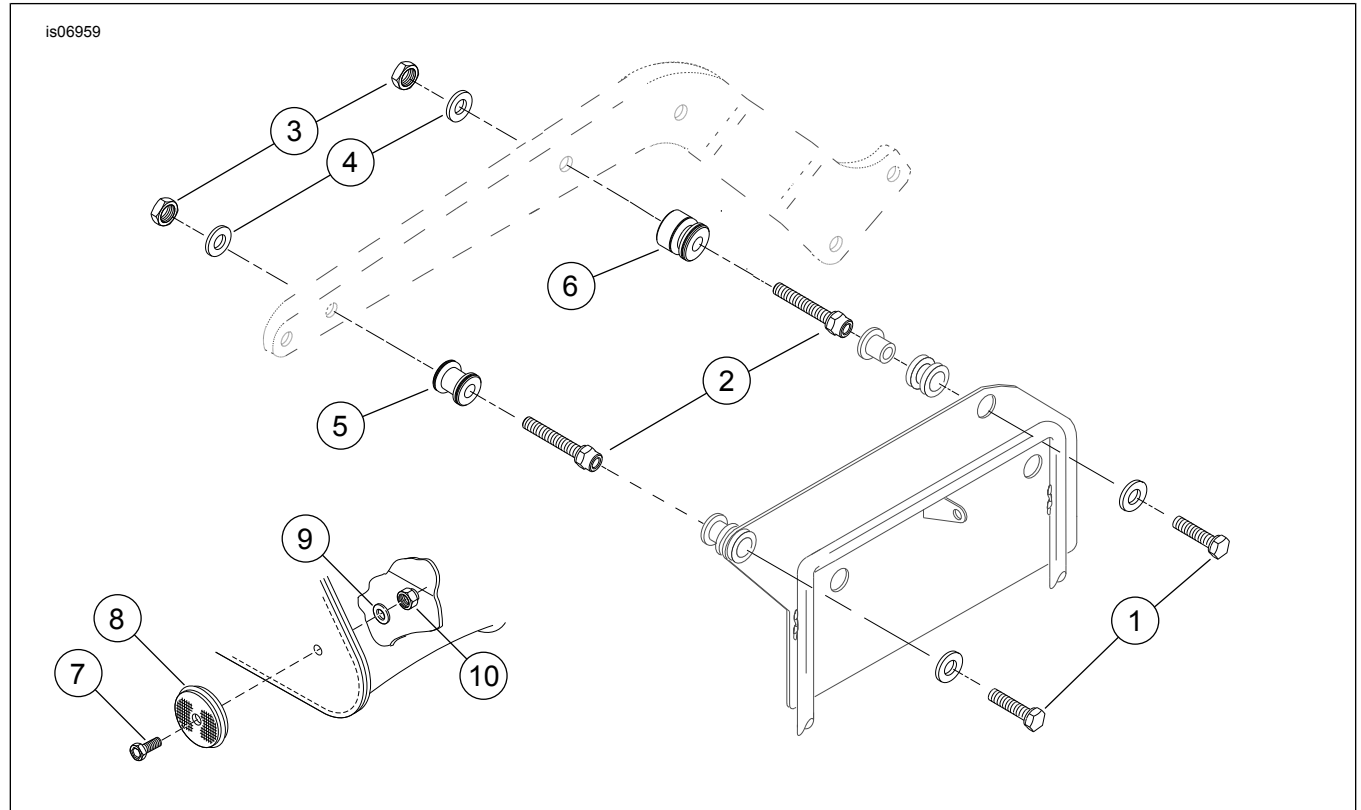

Figure 2. Service Parts: FLSTC Docking Hardware Kit

Table 1. Service Parts Table

Item	Description (Quantity)	Part Number
1	Screws, hex head, 5/16-18 x 7/8, (4)	3991
2	Bushings, support, (4)	90336-95
3	Locknuts, hex, 3/8-16 x 7/16 x 9/16, (4)	7778
4	Washers, 3/8 x 13/16 x 1/16, (4)	6701
5	Docking points, rear, (2)	53684-96A
6	Docking points, front, (2)	53683-96
7	Screws, pan head, #10-32 x 5/8, (2)	2587
8	Reflectors, (2)	59264-86
9	Washers, #10-32 x 1/2 x 1/16, (2)	6716
10	Locknuts, hex, #10-32 x 1/4 x 3/8, (2)	7626W