



INSTRUCTIONS

J00667

2011-03-07



SOFTAIL DOCKING HARDWARE WITH SADDLEBAG SUPPORTS

GENERAL

Kit Number

53370-95C

Models

For model fitment information, see the P&A Retail Catalog or the Parts and Accessories section of www.harley-davidson.com (English only).

Additional Parts Required

Turn Signal Relocation Kit, (Part Number 53692-96) must be installed prior to installing this docking hardware kit on all FXSTS, FXSTSB, FXSTC, AND FLSTF models. **Do not** use Turn Signal Relocation Kit (Part Number 68548-87A) with this kit.

See the P&A Retail Catalog or the Parts and Accessories section of www.harley-davidson.com (English only) for a list of required parts or accessories for your model.

⚠ WARNING

Rider and passenger safety depend upon the correct installation of this kit. Use the appropriate service manual procedures. If the procedure is not within your capabilities or you do not have the correct tools, have a Harley-Davidson dealer perform the installation. Improper installation of this kit could result in death or serious injury. (00333b)

Kit Contents

See Figure 2 and Table 1.

REMOVAL OF SADDLEBAG ASSEMBLY

NOTE

Perform the following procedures on one side of the motorcycle at a time until instructed to go to the other side.

NOTE

Retain saddlebag support, saddlebag, and grab strap

Discard all hardware and the reflectors, unless noted otherwise.

1. See Figure 1. Remove locknuts (5) and washers (4) from bolt ends inside saddlebag.

NOTE

Number 4 washer, (in step 1) is for bags with molded plastic back. If bolts extend through metal plate on inside of bag, washer is not required.

2. Remove saddlebag from bolts (1).

3. Remove washers (9), jam nuts (3), and saddlebag support from bolts (1).
4. Remove grab strap if applicable.
5. Remove bolts (1) and lockwashers (2).
6. Remove acorn nut (7), flat washer (6), bolt (8), and flat washer (10) from fender and fender support. Retain flat washer (10).
7. Repeat steps 1-6 on other side of vehicle.

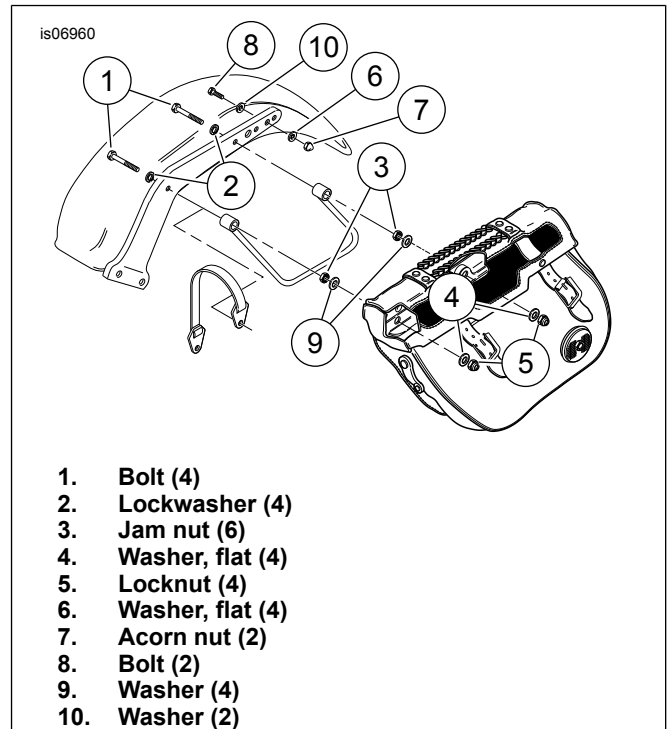

Figure 1. Removal of Saddlebag Assembly (left side)

Turn Signal Relocation

1. On FXSTS, FXSTSB, FXSTC, AND FLSTF models install Turn Signal Relocation Kit (Part Number 53692-96) if not done already.

DOCKING HARDWARE AND SADDLEBAG SUPPORT INSTALLATION

NOTICE

Check that saddlebag frame(s) are fully seated and tightly secured with mounting hardware. Failure to do so could result in the saddlebags becoming detached and/or damaged. (00171b)

NOTE

See Figure 2. The rear docking point (5) is wider than the front docking point (4).



For vehicles with Bad Boy/Diamond Back style saddlebags use the 3-3/4 inch bolts (1).

For vehicles with FLSTF/FLSTN style saddlebags use the 3-1/4 inch bolts (2).

1. Place washers (7) on bolts (1 or 2). Insert bolts (1 or 2) through fender and fender support.
2. If applicable, place grab strap on front bolt (1 or 2).
3. Place spacer (6) on front bolt (1 or 2).
4. Place front docking point (4) on bolt (1 or 2).
5. Place the support bracket on bolts (1 or 2). Secure support bracket to bolts (1 or 2) with jam nuts (8). Torque jam nut to 37 N·m (27 ft-lbs).
6. Insert bolt (3) through rear docking point and into fender.
7. Place flat washer, removed in step 6 on page 1, on bolt (3). Secure bolt (3) with locknut (9). Torque locknut (9) to 37 N·m (27 ft-lbs).
8. Repeat steps 1 - 7 on other side of vehicle.

INSTALL SADDLEBAG

1. See Figure 2. Place washer (7) on bolts (1 or 2).
2. Place saddlebag on bolts (1 or 2).
3. Place washer (7) on bolts (1 or 2) for bags with molded plastic back. If bolts extend through metal plate on inside of bag, washer is not required.

4. Secure saddlebag with locknut (10). Torque locknut to 37 N·m (27 ft-lbs).
5. Repeat steps 1 - 4 on other side of vehicle.

REFLECTOR REMOVAL, PLACEMENT AND INSTALLATION

▲ WARNING

Federal Motor Vehicle Safety Standard (FMVSS) 108 requires motorcycles to be equipped with rear and side reflectors. Be sure rear and side reflectors are properly mounted. Poor visibility of rider to other motorists can result in death or serious injury. (00336b)

1. See Figure 2. Align round reflector (12) with saddlebag. Mark reflector mounting position on saddlebag.
2. Drill a 3/16 in. hole in saddlebag at mounting mark.
3. Install screw (11) to reflector (12) and insert screw to saddlebag. From inside saddlebag install washer (13) and nut (14) and tighten as needed.
4. Repeat steps 1 - 3 on other saddlebag.

MAINTENANCE

1. In time docking points may wear, causing the mating luggage rack or sideplates to become loose. The fit may be tightened using the following procedure:
 - a. Loosen docking hardware.
 - b. Rotate docking points clockwise approximately 45 degrees.
 - c. Tighten docking hardware to the appropriate torque values.
2. Repeat as often as needed, up to 3 times.

SERVICE PARTS

is06962

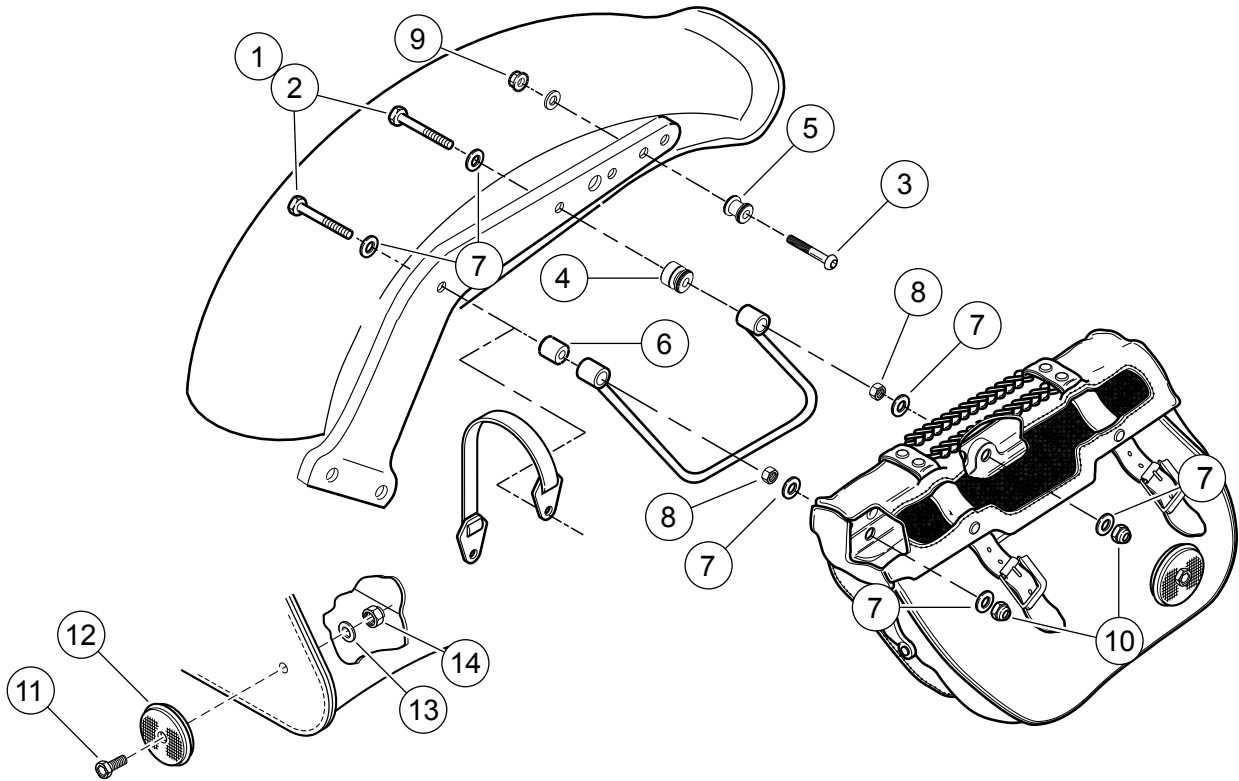

Figure 2. Service Parts: Softail Docking Hardware Kit

Table 1. Service Parts Table

Item	Description (Quantity)	Part Number
1	Bolt, hex head, 3/8-16 x 3-3/4 (4)	4156
2	Bolt, hex head, 3/8-16 x 3-1/4 (4)	3528
3	Bolt, button head chrome, 3/8-16 x 2-1/4 (2)	4154
4	Docking point, front (2)	53683-96
5	Docking point, rear (2)	53684-96A
6	Spacer, saddlebag support (2)	53693-96
7	Washer, 3/8 x 13/16 x 1/16 (12)	6701
8	Jam nut, hex, 3/8-16 x 7/32 x 9/16 (4)	7643W
9	Locknut, hex, 3/8-16 x 7/16 x 9/16 (2)	7778
10	Locknut, hex, nylon cap, 3/8-16 x .62 x 9/16 (4)	7893
11	Screw, pan head, #10-32 x 5/8 (2)	2587
12	Reflector (2)	59264-86
13	Washer, #10 x 1/2 x 1/16 (2)	6716
14	Locknut, hex, #10-32 x 1/4 x 3/8 (2)	7626W