



# INSTRUCTIONS

J01460

2011-03-09



## SOFTAIL DOCKING HARDWARE WITH SADDLEBAG SUPPORTS

### GENERAL

#### Kit Number

53821-00A

#### Models

For model fitment information, see the P&A Retail Catalog or the Parts and Accessories section of [www.harley-davidson.com](http://www.harley-davidson.com) (English only).

#### Additional Parts Required

The FL Softail Wide Tire Hardware Kit (Part Number 43761-00) is required.

The FX Softail Wide Tire Kit is (Part Number 43763-00) is required.

For models 2000 through 2002 equipped with a Softail Wide Tire Kit, utilize the hardware and instructions found in that kit to re-orient the fasteners that come from the inside of the fender.

For models 2000 through 2001, the installation of a Turn Signal Relocation Kit (Part Number 53820-00) will be required prior to the installation of this kit.

For models 2002, the installation of a Turn Signal Relocation Kit (Part Number 53859-02A) will be required prior to the installation of this kit.

Do not use the Turn Signal Relocation Kit (Part Number 68548-87A) with this kit.

#### ⚠ WARNING

**Rider and passenger safety depend upon the correct installation of this kit. Use the appropriate service manual procedures. If the procedure is not within your capabilities or you do not have the correct tools, have a Harley-Davidson dealer perform the installation. Improper installation of this kit could result in death or serious injury. (00333b)**

#### Kit Contents

See Figure 2 and Table 1.

#### INSTALLATION

##### NOTE

Perform the following procedures on one side of the motorcycle until instructed to go to the other side.

1. Refer to the owner's manual and follow the instructions given to remove the seat and retain all hardware.

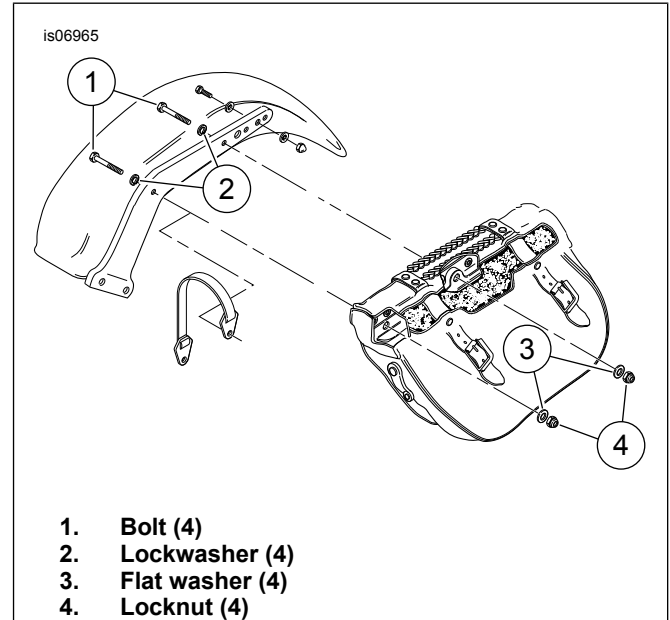

**Figure 1. Removal of Saddlebag Assembly (left side)**

2. See Figure 1. Remove locknuts (4) and washers (3) from bolt ends inside saddlebag.
3. Lift saddlebag away from motorcycle bolts (1).
4. Remove bolts (1) and lockwashers (2).
5. Repeat steps 2-4 on the other side.
6. Install the appropriate Turn Signal Relocation Kit for your model motorcycle.

#### DOCKING HARDWARE/SADDLEBAG SUPPORT INSTALLATION

##### NOTE

See Figure 2. The rear docking point (3) is wider than the front docking point (4).

1. **On Models Without Wide Tire Kit Installed**, place washers (2) on bolts (1). Insert bolts (1) through holes in saddlebag and saddlebag bracket.
2. **2000-2002 Models With Wide Tire Kit Installed** will utilize the hardware and installation instructions included with that kit to re-orient the fasteners to come from the inside of the fender out as shown in Figure 1.
3. Place front docking point (4) on front bolt (1), with countersunk end facing fender support.



4. Place front docking point (4) on front bolt (1), with countersunk end facing fender support.
5. Apply 1-2 drops of Loctite<sup>®</sup> 273 (blue) on threads of bolts (1). Insert bolts (1) through fender support and ?thread? rear bolt into threaded hole in license plate bracket. See note below.
6. Place flat washer (6) on front bolt (1) inside fender. Secure bolt (1) with locknut (7). Tighten front and rear bolts (1) to 37 N·m (27 ft-lbs).

**NOTE**

On the **FLSTF** models secure rearmost screws with 3/8 in. ID washers (Item 6) and 3/8-16 locknuts (Item 7). On all models, **except, FLSTF**, the rearmost screws will engage threads in the license plate bracket. On all other models, place washer between fender and license plate bracket as shown in Service Parts Illustration.

7. After 500 miles of riding with the saddlebags installed, it is necessary to check the torque on the saddlebag mounting bolts. If torque is less than 27 ft-lbs (37 Nm), Re-tighten bolts. See the Caution Below.

**NOTE**

Failure to check and re-tighten the saddlebag mounting bolts to 27 ft-lbs (37 Nm) after 500 miles of riding could result in severe damage to the saddlebags.

8. Repeat steps 1-7 on other side of vehicle.

**MAINTENANCE**

1. In time docking points may wear, causing the mating luggage rack or sideplates to become loose. The fit may be tightened using the following procedure:
  - a. Loosen docking hardware.
  - b. Rotate docking points clockwise approximately 45 degrees.
  - c. Tighten docking hardware to the appropriate torque values.
2. Repeat as often as needed, up to 3 times.

**SERVICE PARTS**

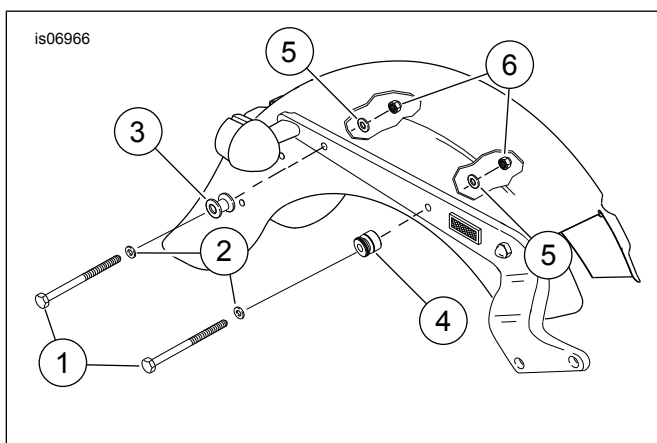

Figure 2. Service Parts: Softail Docking Hardware Kit

Table 1. Service Parts Table

Item	Description (Quantity)	Part Number
1	Bolt, hex head, 3/8-16 x 3-1/4 (4)	3528
2	Washer, 3/8 ID x 0.82 OD x 0.10 (4)	6400HB
3	Docking point, rear (2)	53684-96A
4	Docking point, front (2)	53683-96
5	Washer, 3/8 inside diameter	6701
6	Locknut, hex, 3/8-16 (4)	7667

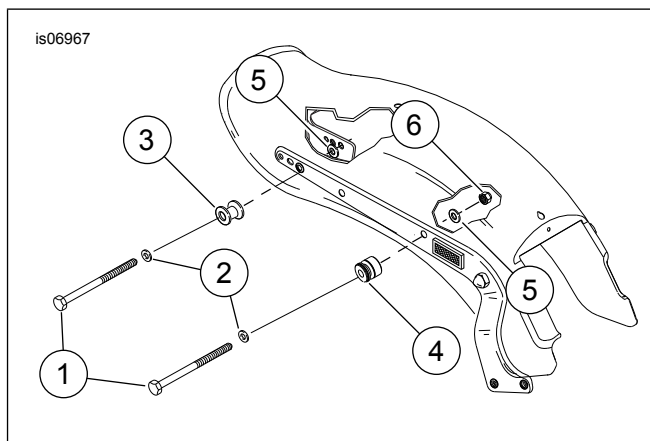

Figure 3. Service Parts: Softail Docking Hardware Kit

Table 2. Service Parts Table

Item	Description (Quantity)	Part Number
1	Bolt, hex head, 3/8-16 x 3-1/4 (4)	3528
2	Washer, 3/8 ID x 0.82 OD x 0.10 (4)	6400HB
3	Docking point, rear (2)	53684-96A
4	Docking point, front (2)	53683-96
5	Washer, 3/8 inside diameter	6701
6	Locknut, hex, 3/8-16 (4)	7667