



INSTRUCTIONS

J01488

2008-06-04



CHROME FORK SLIDERS

GENERAL

Kit Number

45270-98, 45275-98, 45305-98, 45310-98, 45315-98, 46472-00B, 46477-00, 46482-00, 46487-00, 46492-00, 46477-07, 46482-07, 48660-07, 46477-07A, 46482-07A, 48660-07A

Models

For model fitment information, see the P&A Retail Catalog or the Parts and Accessories section of www.harley-davidson.com (English only).

Additional Parts Required

Harley-Davidson TYPE E FORK OIL (99884-80) will be required.

⚠ WARNING

Rider and passenger safety depend upon the correct installation of this kit. Use the appropriate service manual procedures. If the procedure is not within your capabilities or you do not have the correct tools, have a Harley-Davidson dealer perform the installation. Improper installation of this kit could result in death or serious injury. (00333b)

NOTE

This instruction sheet references service manual information. A service manual for your model motorcycle is required for this installation and is available from a Harley-Davidson Dealer.

Tools Required

See the service manual for additional tools required to install this kit.

Kit Contents

See Figure 2, Table 1, Figure 3 and Table 2.

REMOVAL

1. Support the motorcycle so the front end is off the floor and the forks are fully extended.
2. Remove the front fender, front brake caliper(s) and front wheel according to instructions found in the Chassis section of the appropriate service manual.

NOTE

On some models other parts will also need to be removed to access the front forks. See the service manual.

3. **For All Models EXCEPT Touring:** Drain and remove the front forks. See the service manual.

4. **For Touring models equipped with air-adjustable suspension:** Bleed the air-adjustable suspension according to the instructions in the appropriate service manual.

⚠ WARNING

Wear safety glasses or goggles when servicing fork assembly. Do not remove slider tube caps without relieving spring preload or caps and springs can fly out, which could result in death or serious injury. (00297a)

5. **For 2000 and Later Models EXCEPT Touring:** See Figure 1. Using a piece of dental floss (or similar material) in a back and forth motion, loosen reflector from fork slider at both ends. Rotate reflector from side-to-side until it can be removed. Save reflector for future use. See Figure 2. Repeat procedure on the opposite side fork slider. Peel off any excess adhesive from both reflectors. Surface must be clean for installation.
6. Disassemble the front fork tubes according to instructions in the service manual.

INSTALLATION

NOTE

The chrome fork sliders included in this kit install in the same manner as the original equipment parts. Refer to the service manual for proper installation procedures.

Prior to installation of this kit, check the bores of the new chrome sliders to be certain they are free of dirt and debris or damage to the new sliders may occur.

1. Assemble the front fork tubes, replacing worn seals, bushings or other items as needed.

NOTE

Do not use an impact wrench to tighten the drain screws. Use of an impact wrench may damage the screws.

2. Tighten the drain screws:
 - Early Models with 39 mm forks (see Figure 2): Tighten to 13-17 **in-lbs** (1.5-1.9 Nm)
 - Early Models with 41 mm forks (see Figure 2): Tighten to 52-78 **in-lbs** (5.8-8.8 Nm)
 - Later Models (see Figure 3): Tighten to 52-78 **in-lbs** (5.8-8.8 Nm)
3. Fill with TYPE E FORK OIL (99884-80) according to the instructions in the service manual.



4. Install the front fork and any parts that were removed to access the front forks. Install the front fender, wheel and caliper(s) according to instructions in the service manual.
5. **For Touring models equipped with air-adjustable suspension:** Refill the air-adjustable suspension system after assembly according to the service manual instructions.

NOTE

Fork-mounted reflectors are not required on Touring models. The reflectors on Touring models are mounted on the front fender or frame downtubes.

Ambient temperature should be at least 60 °F (16 °C) for proper adhesion of the reflectors.

Allow AT LEAST 24 hours after applying the reflectors before exposing the area to vigorous washing, strong water spray or extreme weather.

▲ WARNING

Federal Motor Vehicle Safety Standard (FMVSS) 108 requires motorcycles to be equipped with rear and side reflectors. Be sure rear and side reflectors are properly mounted. Poor visibility of rider to other motorists can result in death or serious injury. (00336b)

6. **For 2000 - Later Models EXCEPT Touring:** Peel off one side of backing on foam double-sided tape. Press firmly on tape to secure it to reflector. Repeat double-sided adhesive tape installation on remaining reflector. See Figure 1. The bottom edge of reflector should be 2.0 inches (50 mm) above the center of the axle shaft. Remove second side (outside surface) of adhesive backing. Place reflector in position (1) and press reflector firmly into place to activate the adhesive. Repeat for remaining reflector.

▲ WARNING

Whenever a wheel is installed and before moving the motorcycle, pump brakes to build brake system pressure. Insufficient pressure can adversely affect brake performance, which could result in death or serious injury. (00284a)

7. Pump brakes prior to test ride.
8. Test ride the vehicle to verify proper fork travel and rebound.



1. Install bottom of reflector 2.0 inches (50 mm) above center of axle

Figure 1. Reflector Placement

SERVICE PARTS

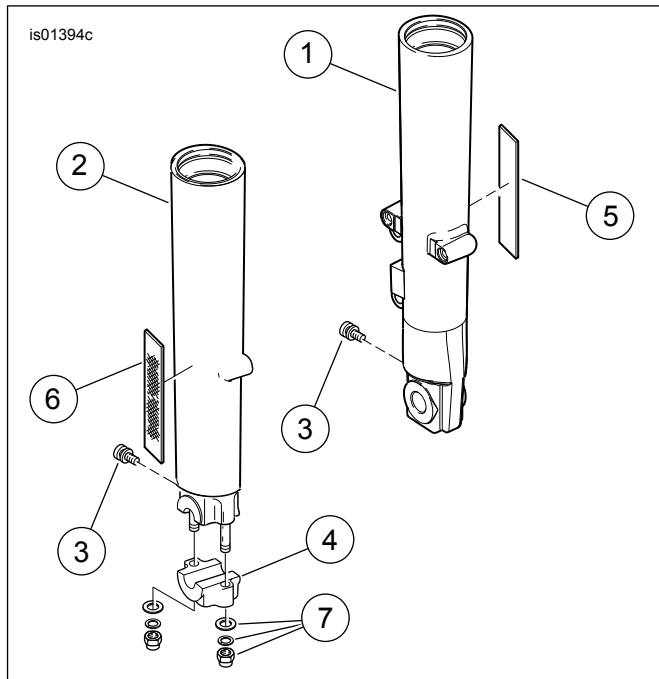

Figure 2. Service Parts: Chrome Fork Sliders - Early Models

Table 1. Service Parts: Chrome Fork Sliders - Early Models

Item	Description (Quantity)	Part Number
1	Fork slider, left side (chrome)	
	• Kit 45270-98 (39 mm)	46272-98
	• Kit 45275-98 (39 mm)	46272-98
	• Kit 45305-98 (41 mm)	46307-98
	• Kit 45310-98 (41 mm)	45311-98
	• Kit 45315-98 (41 mm)	46317-98
	• Kit 46472-00B (41 mm)	46473-00B
	• Kit 46477-00 (41 mm)	46478-00
	• Kit 46482-00 (41 mm)	46483-00
	• Kit 46487-00 (39 mm)	46488-00
	• Kit 46492-00 (39 mm)	46488-00
	• Kit 46477-07 (41 mm) (includes item 3)	46478-07
	• Kit 48660-07 (41 mm) (includes item 3)	48733-07
	• Kit 46482-07 (41 mm) (includes item 3)	46483-07
2	Fork slider, right side (chrome)	
	• Kit 45270-98 (39 mm)	46271-98
	• Kit 45275-98 (39 mm)	46483-07
	• Kit 45305-98 (41 mm)	48731-07
	• Kit 45310-98 (41 mm)	45312-98
	• Kit 45315-98 (41 mm)	46316-98
	• Kit 46472-00B (41 mm)	46474-00C
	• Kit 46477-00 (41 mm)	46479-00
	• Kit 46482-00 (41 mm)	46484-00
	• Kit 46487-00 (39 mm)	46489-00
	• Kit 46492-00 (39 mm)	46493-00
	• Kit 46477-07 (41 mm) (includes items 3 and 7)	46479-07
	• Kit 48660-07 (41 mm) (includes items 3 and 7)	48732-07
	• Kit 46482-07 (41 mm)> (includes items 3 and 7)	46484-07
3	Drain screw with washer (2)	
	• 39 mm fork kits	45858-77
	• 41 mm fork kits	45790-80
	• 41 mm fork kits*	45369-99, 45692-99
4	Axle holder (right side only)	
	• Kit 46477-07, 48660-07, 46482-07	46499-00
	• Kit 46472-00B	46658-07
	• For all other 41 mm fork kits	45303-98
5	Reflector, left side (2000-2006, except 46472-00B) (not included in kit)	59482-00
6	Reflector, right side (2000-2006, except 46472-00B) (not included in kit)	59481-00
7	Nut, axle cap, chrome	45813-03
8	Tape, double-sided, foam, reflector (2) (not shown)	53791-06
9	Reflector (2007) (2) (not included in kit) (not shown)	60253-07
* For use with kits 46477-07, 48660-07, 46482-07 Screw (chrome) Washer		
** For use with kits 46479-07, 48732-07, 46484-07, 48730-07		

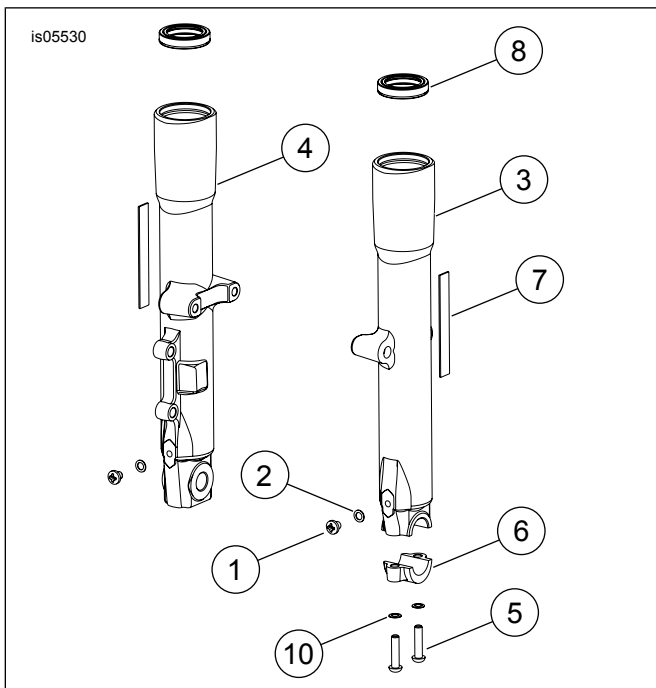

Figure 3. Service Parts: Chrome Slider Kits - Later Models

Table 2. Service Parts: Chrome Fork Sliders - Later Models

Item	Description (Quantity)	Part Number
1	Screw (2)	45369-99
2	Washer (2)	45692-99
3	Fork slider, right side (chrome)	
	• Kit 46477-07A	46479-08
	• Kit 46482-07A	46484-08
	• Kit 48660-07A	48732-08
4	Fork slider, left side (chrome)	
	• Kit 46477-07A	46478-07
	• Kit 46482-07A	46483-07
	• Kit 48660-07A	48733-07
5	Screw (2)	4042
6	Holder, right axle (chrome)	46499-00
7	Tape, double-sided foam (2)	53791-06
8	Oil seal (2)	45875-84A
9	Label (not shown)	60812-06
10	Lockwasher (2)	7062