



# INSTRUCTIONS

J03706

2011-02-04



## LOWER BELT GUARD

### GENERAL

#### Kit Number

60317-06, 60654-07A, 60655-07A, 57100179, 57100180

#### Models

For model fitment information, see the P&A Retail Catalog or the Parts and Accessories section of [www.harley-davidson.com](http://www.harley-davidson.com) (English only).

#### Additional Parts Required

##### ⚠ WARNING

Rider and passenger safety depend upon the correct installation of this kit. Use the appropriate service manual procedures. If the procedure is not within your capabilities or you do not have the correct tools, have a Harley-Davidson dealer perform the installation. Improper installation of this kit could result in death or serious injury. (00333b)

##### NOTE

This instruction sheet references service manual information. A service manual for your model motorcycle is required for this installation and is available from a Harley-Davidson Dealer.

#### Kit Contents

See Figure 3 and Table 1.

#### REMOVAL

1. See Figure 1. Remove two bolts (1) from rear inner fender (2). Lift upper right corner of fender and lift upward. Save parts for later use.
2. See Figure 2. Remove acorn bolt (1) from lower belt guard (2) and rear fork bracket (3). Save acorn bolt for later use.
3. Remove screw (4) that mounts rear fork (5) to front (slotted) portion of lower belt guard. Save screw for later use.
4. Hold screw (6) and washer (7) with wrench to remove acorn nut (8). Then remove screw and washer that attaches lower and upper belt guards (2, 9). Save hardware for later use.
5. Remove original equipment lower belt guard (2) from rear fork.

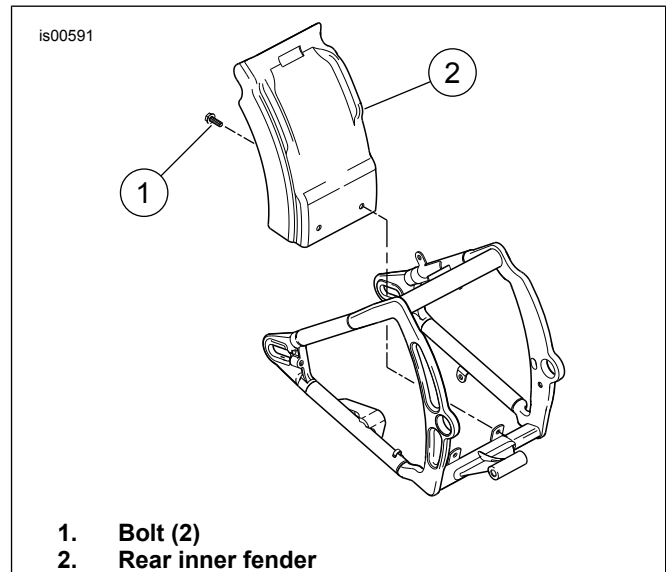

Figure 1. Rear Inner Fender

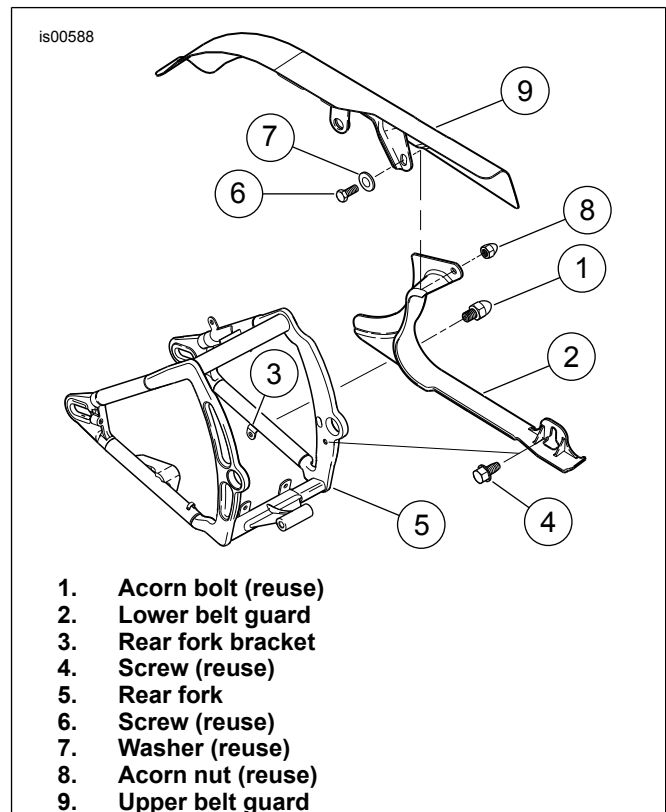

Figure 2. Stock Lower Belt Guard

## INSTALLATION

1. See Figure 3 and Table 1. Place lower belt guard (1) into position. Install screw (A) and washer (2) into front mounting hole of lower belt guard (1).
2. Install screw (B) and washer (C) through upper (D) and lower (1) belt guards, and rear fork (E). Install acorn nut (F) securely.
3. Install acorn bolt (G) to lower belt guard and rear fork bracket (H).
4. Tighten screw (A) at front of lower belt guard and rear fork to 84-108 **in-lbs** (9.5-12.2 Nm).
5. Tighten all upper and lower belt guard hardware to 60-96 **in-lbs** (6.8-10.8 Nm).

## SERVICE PARTS

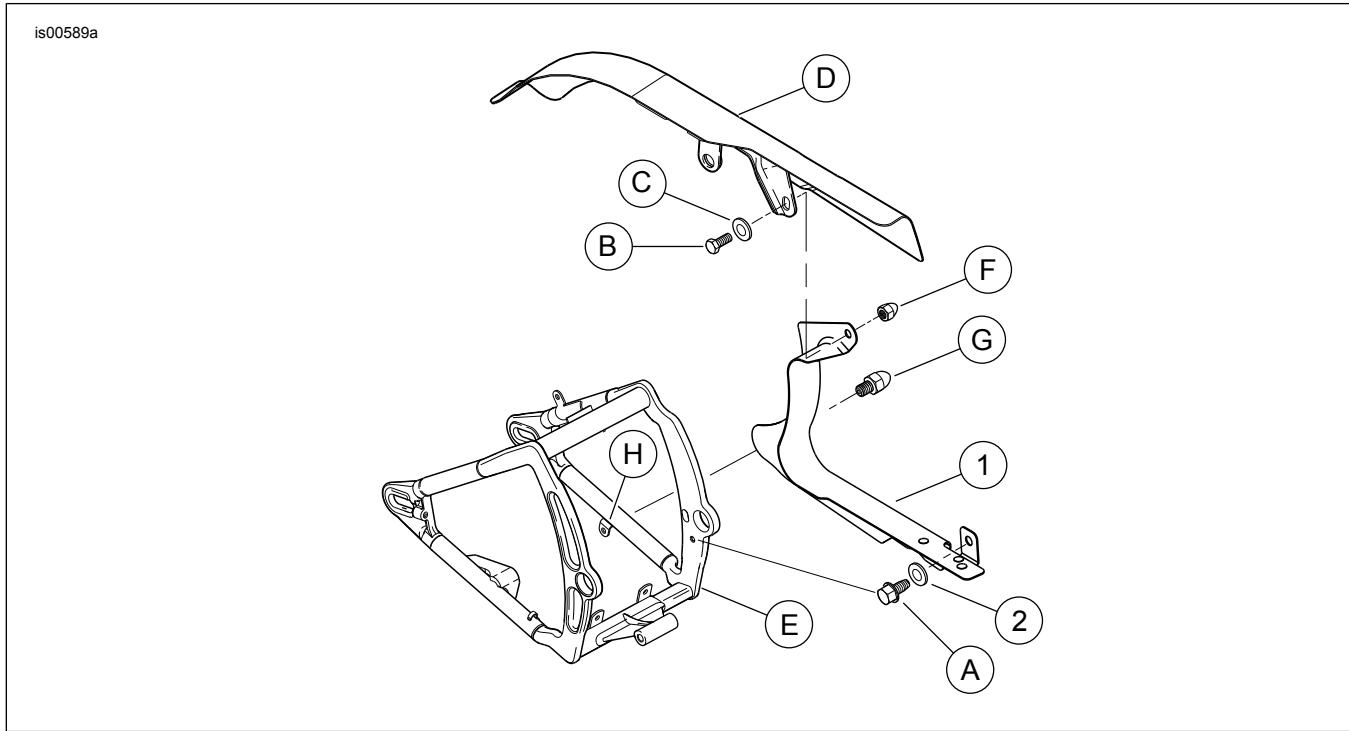

Figure 3. Service Parts: Lower Belt Guard

Table 1. Service Parts: Lower Belt Guard

Item	Description (Quantity)	Part Number
1	Lower belt guard	Not Sold Separately
2	Flat washer, 5/16 in.	6702
<b>Items mentioned in text, but not included in kit:</b>		
A	Screw	
B	Screw	
C	Washer	
D	Upper belt guard	
E	Rear fork	
F	Acorn nut	
G	Acorn bolt	
H	Rear fork bracket	