



# INSTRUCTIONS

J03965

2006-09-08



## RIGID SIDEPLATE MOUNTING KIT

### GENERAL

#### Kit Number

53975-06

#### Models

For model fitment information, please see the P&A Retail Catalog or the Parts and Accessories section of [www.harley-davidson.com](http://www.harley-davidson.com) (English only).

#### Additional Parts Required

After installing this kit a Turn Signal Relocation Kit (68732-02A - Domestic or 68733-02A - HDI) must also be installed.

Proper installation of this kit requires Loctite® 243 (blue) (99642-97) and Loctite® 262 (red) (94759-99), which is available from any Harley-Davidson dealership.

#### Kit Contents

See Figure 4 and Table 1.

### INSTALLATION

#### NOTE

When performing the following installation procedures, be cautious not to scratch painted surfaces (fender, tank, etc.).

1. Place motorcycle on a lift and secure front tire.

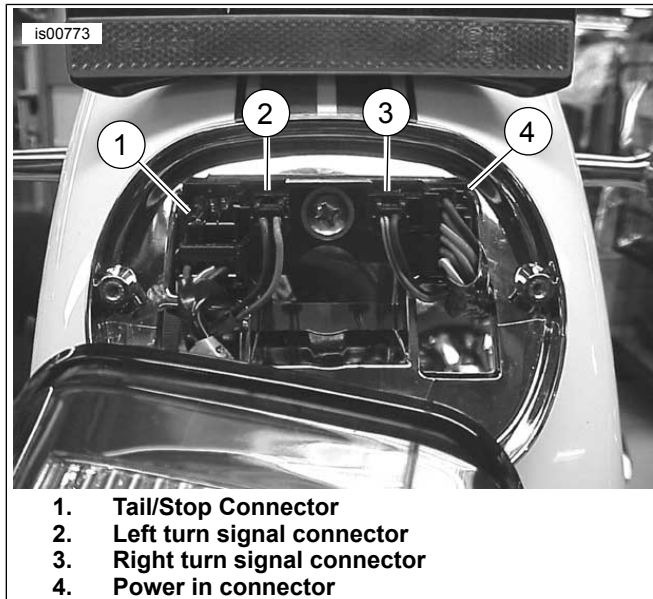

Figure 1. Remove Connectors

#### ⚠ WARNING

To prevent accidental vehicle start-up, which could cause death or serious injury, disconnect negative (-) battery cable before proceeding. (00048a)

2. Disconnect battery negative (-) cable.
3. If the stock reflectors are located on the rear fender, remove the reflectors. Clean adhesive from back side of reflector. Attach reflector to fender support cover using new double sided tape (53791-06) from the Sideplate kit.
4. Place a scissor jack under the frame for support and so that the rear wheel can be raised and lowered.
5. Remove upper shock bolts from both sides of the motorcycle.
6. See Figure 1. Remove two screws and tail light assembly from mounting bracket. Disconnect tail light harness (1) and set the tail light assembly aside.
7. See Figure 1. Disconnect both rear turn signal harnesses (2 & 3) from the tail light base.
8. See Figure 2. Remove turn signal mounting screw (4), lock washer (5) and rear turn signal assembly (6).
9. See Figure 2. Remove screw (1), washer (2), rear fender bracket (9 or 10) and fender strut cover (8). Discard screw, washer and bracket.

#### NOTE

See Figure 3 for Steps 10 through 13.

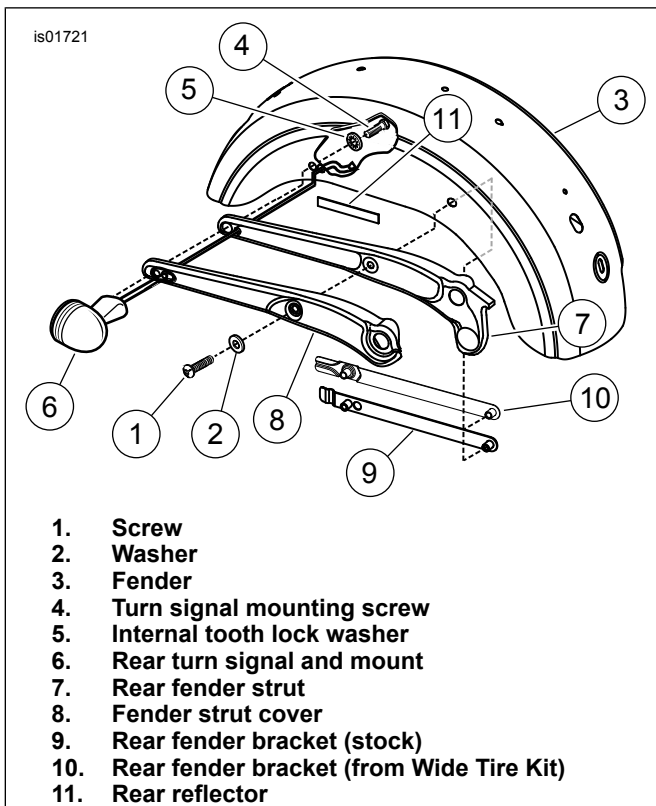

**Figure 2. Remove Turn Signals and Rear Fender Bracket**

10. Obtain a new fender bracket (4) from the kit and install it in the same location as the previously removed rear fender bracket, then install the sideplate (8) over the fender bracket between the fender (7) and the fender strut (6).
11. Apply Loctite 243 (Blue) to a button head screw from the kit. Install the button head screw (1) and a washer (2) from the kit through the forward hole of the sideplate (8) and rear fender bracket (4).
12. Apply Loctite 243 (Blue) to a button head screw from the kit. Install the button head screw (1), two washers (2) and one recess cover spacer (3) from the kit through the rearward hole of the sideplate (8) and rear fender bracket (4).
13. Tighten the button head screws to 24 N·m (18 ft-lbs).
14. Repeat Steps 8 through 13 for the opposite side of the motorcycle.
15. Apply Loctite 262 (red) to the 1/4-20 x 5/8 inch screws from the Sideplate Kit and install uprights. Tighten screws to 13.5 N·m (10 ft-lbs).

16. Install a Turn Signal Relocation Kit (68732-02A - Domestic or 68733-02A - HDI) according to the Instruction Sheet (-J03107) included with the kit.
17. Apply Loctite 243 (blue) to the upper shock bolts. Install upper shock bolts and spacers. Tighten upper shock bolts to 102–115 N·m (75–85 ft-lbs).
18. See Figure 1. Connect turn signals connectors (2 and 3) if not already connected, and tail light connector (1).
19. Install tail light to rear fender using two tail light mounting screws removed previously.
20. Connect battery negative (-) cable.

**▲ WARNING**

**Be sure that all lights and switches operate properly before operating motorcycle. Low visibility of rider can result in death or serious injury. (00316a)**

21. Verify turn signal, brake and tail light operation.

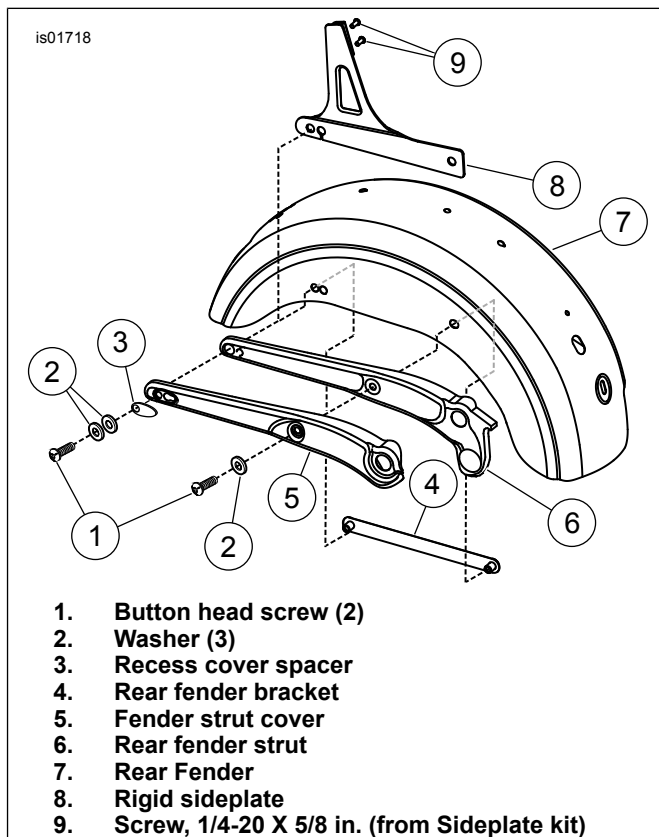

**Figure 3. Sideplate Installation (Right Side Shown)**

# SERVICE PARTS

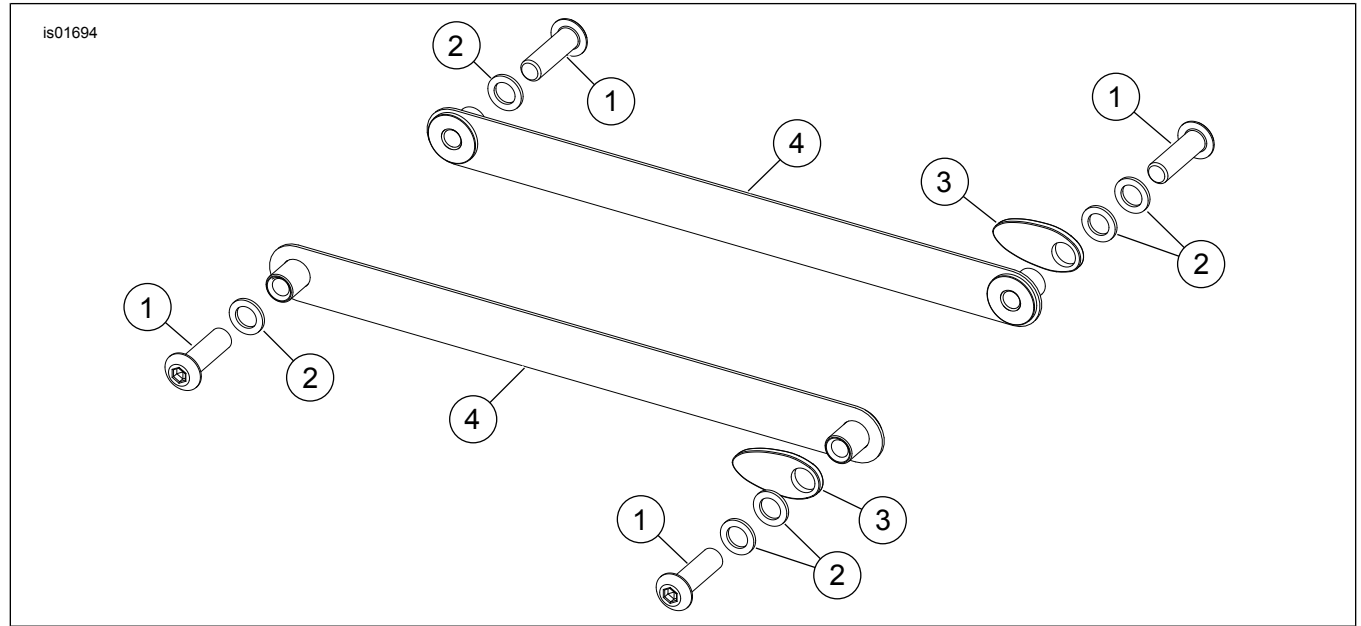

Figure 4. Service Parts for Rigid Sideplate Mounting Kit

Table 1. Service Parts Table

Item	Description (Quantity)	Part Number
1	Button head screw (4)	4098
2	Washer (6)	6874
3	Recess cover spacer (2)	47531-06
4	Rear fender bracket (2)	59484-06