



INSTRUCTIONS

J02483

2005-07-21



LICENSE PLATE HARDWARE KIT

GENERAL

Kit Number

94114-02 and 94546-05

Models

These kits are designed to fit all license plate brackets that use 1/4 inch screws to fasten the license plate to the license plate bracket.

Kit Contents

Table 1. Kit Contents

Description (Quantity)	Part Number
Wrench	Not sold
Screw, 1/4-20 x 0.5 in. (4)	Not sold
Lockwasher (4)	94080-90T
Nut, 1/4-20 (4)	94041-90T

INSTALLATION

1. Remove and discard the hardware fastening the license plate to the license plate bracket.
2. See Figure 1 and 2. Insert a screw (3) through a mounting hole in the front of the license plate and bracket.
3. From behind the license plate bracket, loosely fasten a lockwasher (2) and nut (1) to the screw.
4. Repeat steps 2 and 3 for all mounting holes in the license plate and bracket.
5. Use the wrench (4) to hold the screw heads straight while securely tightening the nuts behind the license plate bracket.

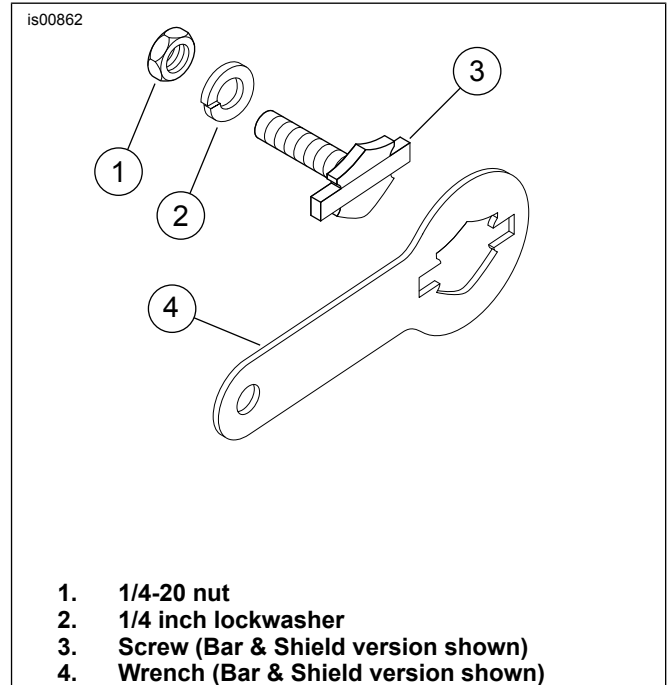

Figure 1. License Plate Hardware

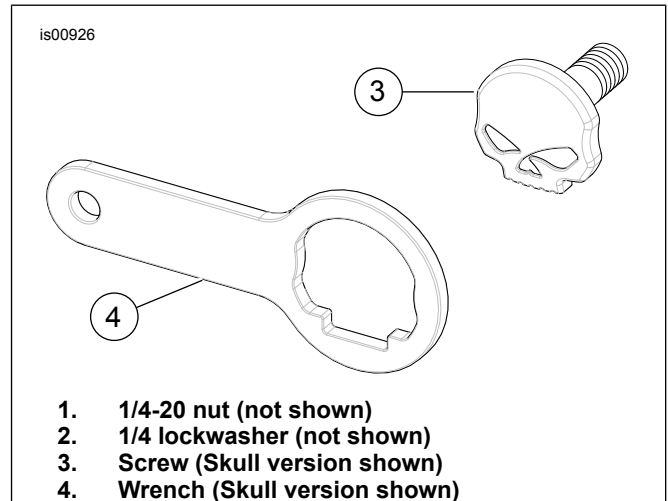

Figure 2. License Plate Hardware

