



# INSTRUCTIONS

J01832

2007-02-01



## SOFTAIL CHROME FRONT WHEEL SPACER KITS

### GENERAL

#### Kit Number

41583-03, 41597-00, 41618-03

#### Models

For model fitment information, please see the P&A Retail Catalog or the Parts and Accessories section of [www.harley-davidson.com](http://www.harley-davidson.com) (English only).

#### Additional Parts Required

Separate purchase of Anti-Seize Lubricant (Harley-Davidson Part Number 98960-97) is required for proper installation of this kit on your model motorcycle. Anti-Seize Lubricant is available from any Harley-Davidson Dealer.

#### ⚠ WARNING

Rider and passenger safety depend upon the correct installation of this kit. Use the appropriate service manual procedures. If the procedure is not within your capabilities or you do not have the correct tools, have a Harley-Davidson dealer perform the installation. Improper installation of this kit could result in death or serious injury. (00333b)

#### NOTE

This instruction sheet references Service Manual information. A Service Manual for your model motorcycle is required for this installation and is available from a Harley-Davidson Dealer.

#### Kit Contents

See Figure 3 and Table 1.

There are no Service Parts available with this kit.

#### INSTALLATION

1. Block the motorcycle underneath the frame so the front wheel is raised off the ground.
2. See Figure 1. Remove the top brake caliper mounting bolt (1) (long) and bottom mounting bolt (2) (short) and brake caliper. Support the caliper using a rubber bungee cord. Be careful not to scratch the fender paint.

#### NOTE

Do not operate the front brake lever with the front wheel removed or the caliper piston(s) may be forced out of the piston bore(s). Re-seating the piston(s) requires disassembly of the caliper.

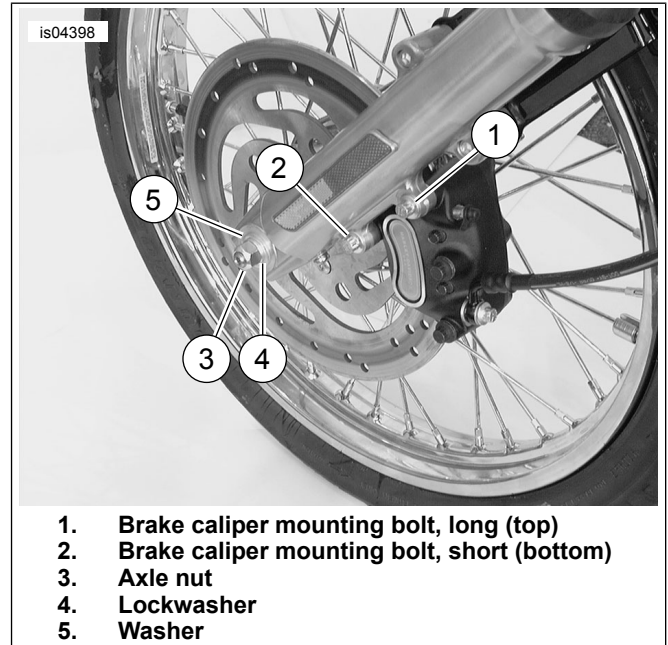

Figure 1. Caliper Mounting Bolts (Left Side Shown)

3. Remove the axle nut (3), lockwasher (4) and washer (5).
4. See Figure 2. Remove the wheel from the forks. Loosen the slider cap nuts (1) and pull the axle (2) free.

#### NOTE

When performing the following procedures, leave the bearing assemblies in place.

5. See Figure 3. **All models except FLSTC:** Remove and discard the stock wheel spacers. **For FLSTC models:** Remove and discard the stock hub cap (A), wheel spacers (B) and snap ring (C).
6. Obtain the chrome spacers from the kit. Install the longer spacer (2) on the left side, and the shorter spacer (1) on the right side of the wheel. The spacers have chamfers on each end, and can be installed in either direction.
7. Apply a light coat of ANTI-SEIZE LUBRICANT (Harley-Davidson Part Number 98960-97) to the axle.
8. See Figure 2. Place the wheel into the front fork and install the axle (2). Verify that the axle spacers are properly installed on the right and left sides.



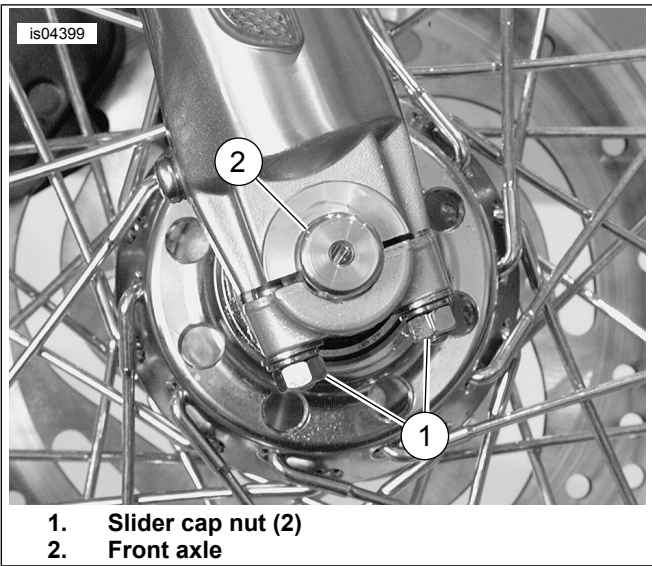

- 1. Slider cap nut (2)
- 2. Front axle

Figure 2. Front Wheel Mounting (Right side Shown)

9. Figure 1. Install the washer (5), lockwasher (4) and axle nut (3). See Figure 2. Tighten the slider cap nuts (1) to 14.9–20.3 N·m (11–15 ft-lbs). See Figure 2. Hold the axle stationary while tightening the axle nut (2) to 61–74.6 N·m (50–55 ft-lbs).
10. See Figure 1. Install the brake caliper to the fork legs in the following sequence:
  - a. Loosely install the mounting bolt (1) (long) to the top hole on the fork leg.
  - b. Install the mounting bolt (2) (short) to the bottom hole and tighten to 38–51.5 N·m (28–38 ft-lbs).
  - c. Final tighten the top mounting bolt to 38–51.5 N·m (28–38 ft-lbs).
11. Pump the brake lever to move the pistons out until they contact both brake pads. Verify piston location against the pads.

## SERVICE PARTS

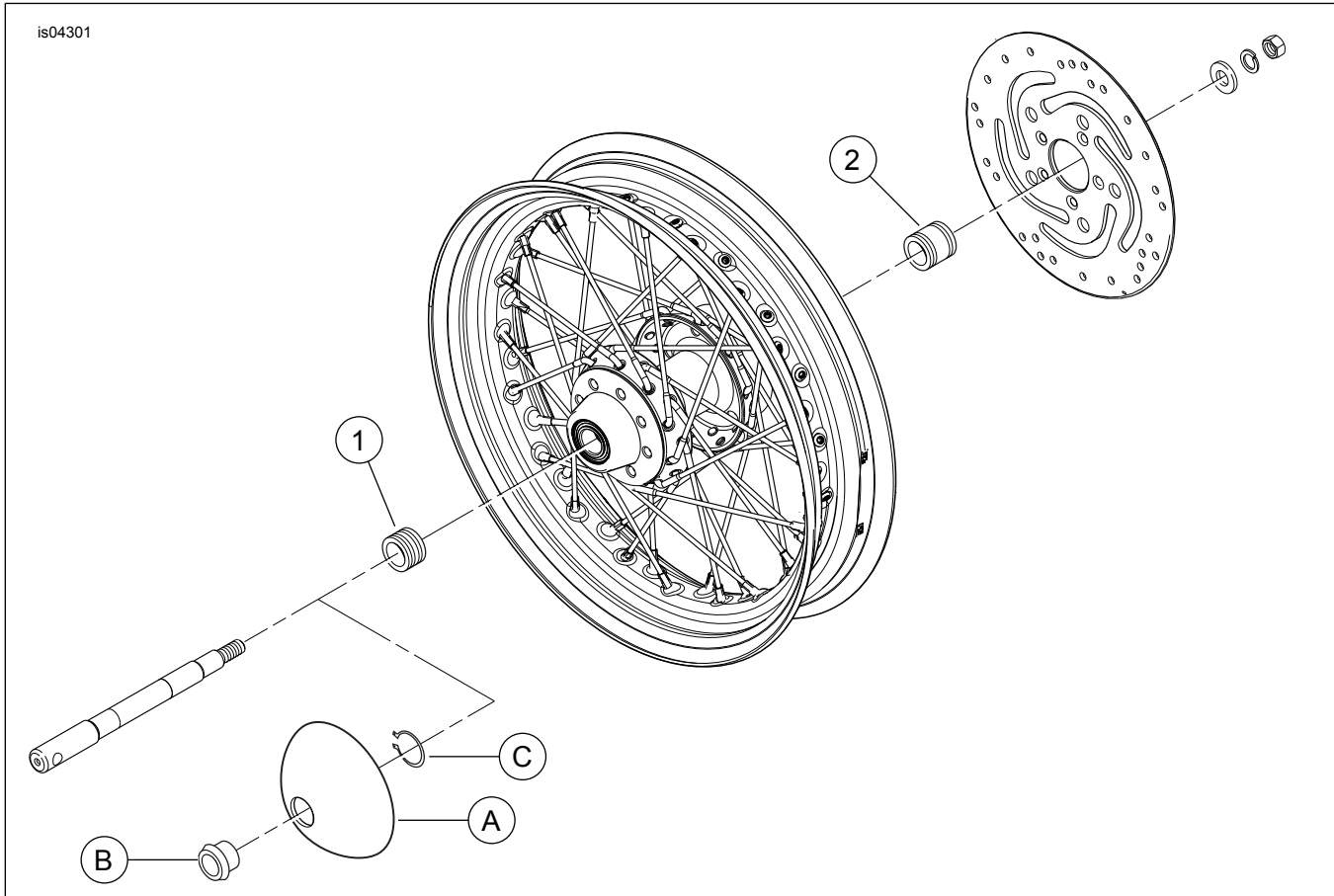

Figure 3. Service Parts: Chrome Front Wheel Spacer Kits

Table 1. Service Parts Table

Kit	Item	Description	Part Number
41597-00	1	Spacer, right side (short), 0.893 in. (23 mm) wide	Not sold separately
	2	Spacer, left side (long), 0.993 in. (25 mm) wide	Not sold separately
41583-03	1	Spacer, right side (short), 0.523 in. (13 mm) wide	Not sold separately
	2	Spacer, left side (long), 0.993 in. (25 mm) wide	Not sold separately

**Table 1. Service Parts Table**

<b>Kit</b>	<b>Item</b>	<b>Description</b>	<b>Part Number</b>
41618-03	1	Spacer, right side (short), 0.523 in. (13 mm) wide	Not sold separately
	2	Spacer, left side (long), 0.993 in. (25 mm) wide	Not sold separately
Items mentioned in text, but not included in kit:			
	A	Hub cap	
	B	Spacer	
	C	Snap ring	