



# INSTRUCTIONS

J01872

2010-05-17



## SECURITY SYSTEM SMART SIREN AND SMART SIREN II BATTERY REPLACEMENT KIT

### GENERAL

#### Kit Number

69309-10

#### Models

This kit fits all Harley-Davidson® motorcycles equipped with a Harley-Davidson Factory Security System.

#### Kit Contents

This kit contains the items needed to replace the 9-Volt NiMH (Nickel Metal Hydride) rechargeable battery installed in the security system Smart Siren.

For kit contents, see Figure 7 and Table 1.

The **battery** in this kit can also be used to replace the 9-Volt NiMH battery installed in the security system Smart Siren II. However, note that the other items in the kit are not required for the Smart Siren II.

The Smart Siren II can be identified by the presence of a pager transmitter antenna wire (see Figure 5 ) next to the connector receptacle. The Smart Siren has no antenna wire.

### SIREN BOX REMOVAL

#### NOTICE

Read the following instructions and make sure you fully understand them prior to replacing the battery. If the procedure is not within your capabilities, or you do not have the correct tool, have a Harley-Davidson dealer replace the battery. Improper installation could result in damage to this product. (00419b)

1. Refer to the Owner's Manual and follow the instructions given to disarm the security system.
2. Remove the siren box from the vehicle. Reference the siren installation procedures found in the Siren Kit Instruction Sheet or contact a Harley-Davidson dealer for specific information on locating and removing the siren box from your model.

### Battery replacement, Smart Siren

1. See Figure 1. Remove the battery cover (2) from the siren box as follows:
  - a. Place the siren on a sturdy, flat surface with the potting (1) and battery cover facing up.

- b. Using a blunt, stiff blade such as a table knife, insert the blade between the case and cover at a 45 degree angle to the side of the case. Insert the blade until it touches the snaps on the inside face of the cover. Figure 2 shows the four barbed snaps (2).
- c. Twist the blade slowly so the inserted edge presses against the inside face of the cover. The cover will pop off and can be replaced later using silicone adhesive if necessary.

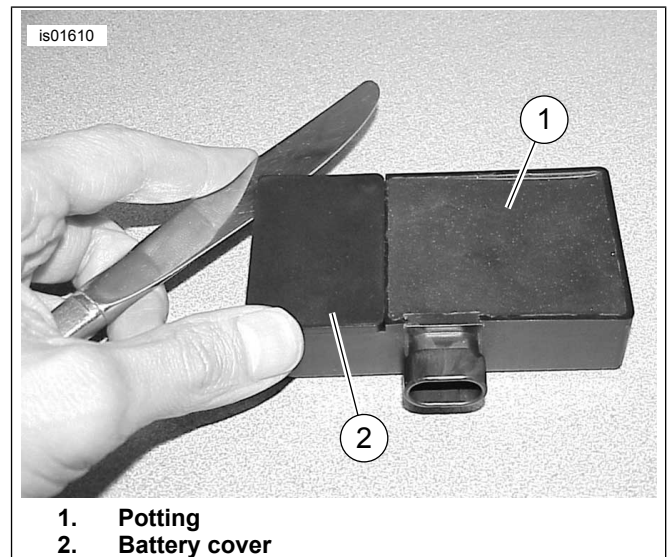
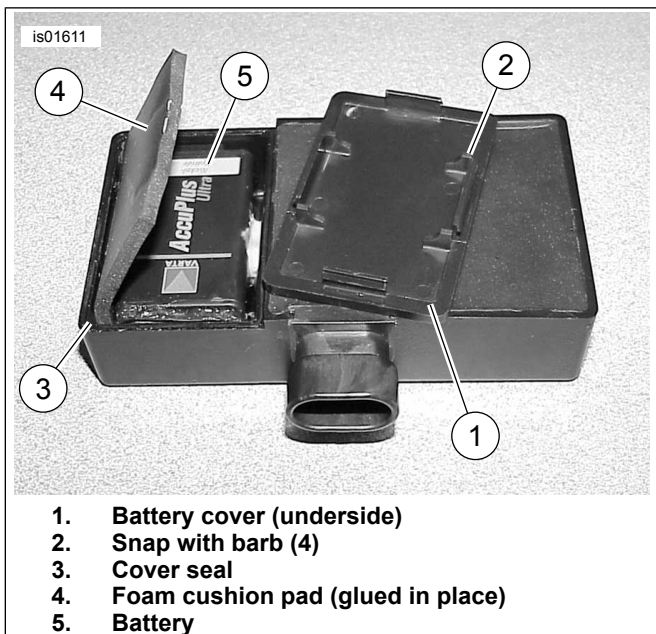

Figure 1. Insert Blade Between Case and Cover (Smart Siren)





**Figure 2. Remove and Replace Battery and Seal (Smart Siren)**

2. See Figure 2. Raise the top flap on the foam cushion pad (4). Remove the old battery (5) from the siren box, and gently unfasten the snap connector from the battery. Save the grease coating the terminals.
3. Obtain the **new** nickel metal hydride (NiMH) nine-volt battery from the kit. Coat the terminals of the snap connector and the new battery completely with the grease from the old connection.

**NOTE**

*If not enough lubricant remains to completely cover the terminals, Electrical Contact Lubricant (Part Number 99861-02) is compatible, and is available from a Harley-Davidson dealer*

4. Snap the connector onto the new battery, and install the battery into the siren box.
5. Replace the old cover seal (3) with the **new** seal from the kit, inserting it fully into the groove of the battery compartment wall.

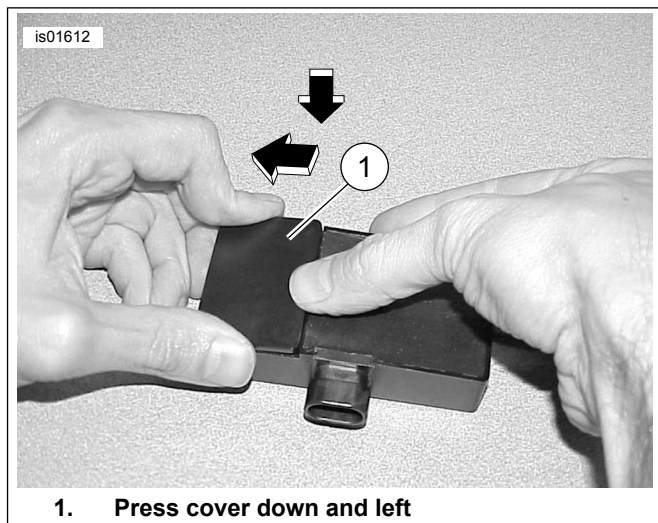

**1. Press cover down and left**

**Figure 3. Align and Center Cover (Smart Siren)**

6. Lay the top flap of the foam cushion pad over the top of the battery.
7. Replace the battery door cover, using silicone adhesive if necessary.

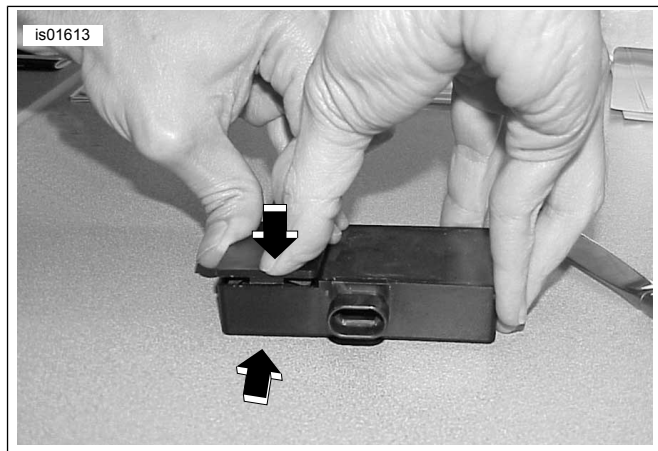

**Figure 4. Engage Snaps (Smart Siren)**

8. Proceed to SIREN BOX TEST AND INSTALLATION.

**Battery Replacement, Smart Siren II**

1. See Figure 5. Remove the battery cover (2) from the siren box as follows:
  - a. Place the siren on a sturdy, flat surface with the potting (1) and battery cover facing up.
  - b. Insert a flat-blade screwdriver into one of the slots (3) on the side of the siren box. Press until one corner of the cover pops up slightly.
  - c. Insert the screwdriver into the second slot, and press until the cover pops open.

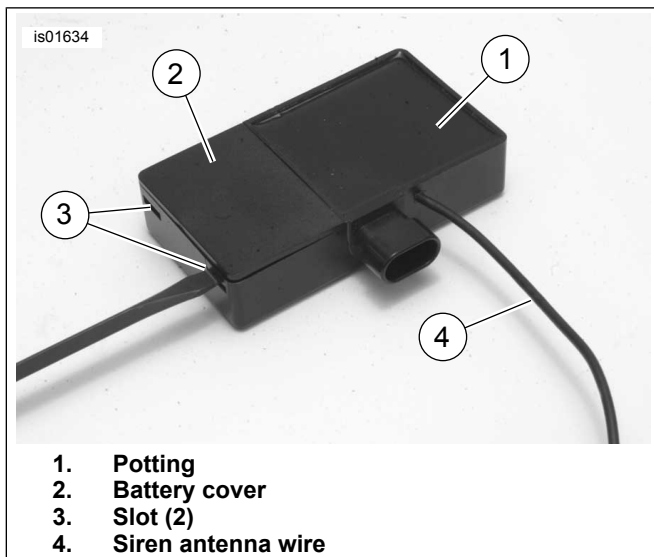

Figure 5. Insert Screwdriver Into Slots (Smart Siren II)

- Remove the old battery from the siren box, and gently unfasten the snap connector from the battery. Save the grease coating the terminals.
- Coat the terminals of the snap connector and the **new nickel metal hydride (NiMH) nine-volt battery** completely with the grease from the old connection.

**NOTE**

*If not enough lubricant remains to completely cover the terminals, Electrical Contact Lubricant (Part Number 99861-02) is compatible, and is available from a Harley-Davidson dealer*

- Snap the connector onto the new battery, and install the battery into the siren box.

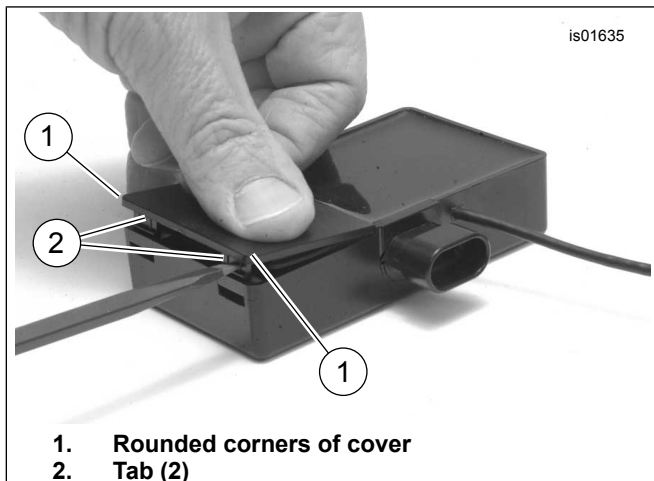

Figure 6. Snap Tabs Into Slots (Smart Siren II)

- See Figure 6. Position the **original** battery cover onto the siren box with the rounded corners (1) facing out.
- Press the cover down onto the siren box and press the tabs (2) in with the screwdriver until the tabs snap into the slots in the box.

- Proceed to SIREN BOX TEST AND INSTALLATION.

## SIREN BOX TEST AND INSTALLATION

- Reconnect the siren to the Security System Module (TSSM) and test the siren by arming the system. The siren should respond with two chirps.

**NOTE**

*The siren may not function properly when first installed. NiMH (Nickel Metal Hydride) rechargeable batteries discharge fairly rapidly when stored. They will lose as much as 1% - 2% of their charge per day, and after a few months of storage at room temperature will be mostly discharged. If stored for a very long period without charging, they may need a few charging cycles to regain their full capacity.*

*To charge the NiMH battery, operate your motorcycle for a minimum of 4 hours.*

- Disarm the system and finish re-assembly. Reference the siren installation procedures found in the Siren Kit Instruction Sheet or contact a Harley-Davidson dealer for specific information on installing the siren box to your model.

## SERVICE PARTS

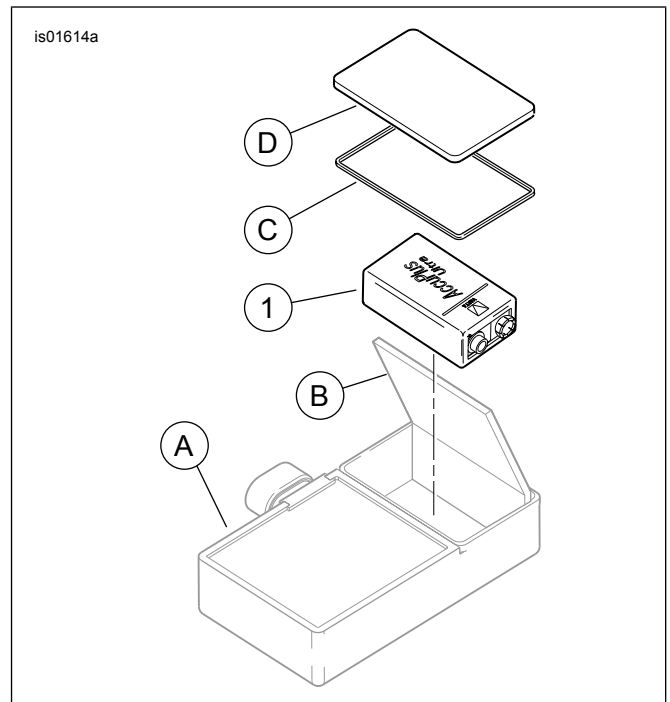

Figure 7. Service Parts, Kit 69309-10

Table 1. Service Parts

Item	Description (Quantity)	Part Number
1	Battery, NiMH, 9-Volt DC	Not Sold Separately
<b>Items mentioned in text, but not included in kit.</b>		
A	Smart Siren, security system	
B	Foam cushion pad	
C	Seal, battery cover (Smart Siren)	
D	Cover, battery (Smart Siren)	