



INSTRUCTIONS

J04169

2007-02-28



XL HAND LEVER

GENERAL

Kit Number

44992-07, 46944-07A

Models

These kits fit all 2004 and later XL Sportster® model motorcycles.

Additional Parts Required

▲ WARNING

Rider and passenger safety depend upon the correct installation of this kit. Use the appropriate service manual procedures. If the procedure is not within your capabilities or you do not have the correct tools, have a Harley-Davidson dealer perform the installation. Improper installation of this kit could result in death or serious injury. (00333b)

NOTE

This instruction sheet references Service Manual information. A Service Manual for your model motorcycle is required for this installation and is available from a Harley-Davidson Dealer.

Kit Contents

See Figure 2 and Table 1.

BRAKE LEVER INSTALLATION

Removing the Brake Lever

NOTICE

Do not remove or install the master cylinder assembly without first positioning a 5/32-inch (4 mm) thick insert between the brake lever and lever bracket. Removing or installing the master cylinder assembly without the insert in place may result in damage to the rubber boot and plunger on the front stoplight switch. (00324a)

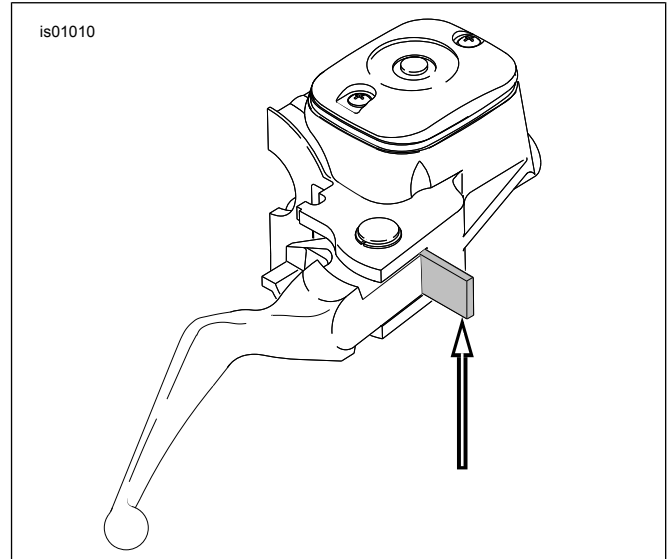

Figure 1. 5/32 in. (4 mm) Cardboard Insert

1. See Figure 1. Squeeze the brake lever and place the cardboard insert between the brake lever and lever bracket.

NOTE

Use the eyelet of an ordinary cable strap if the cardboard insert is not available.

▲ WARNING

Wear safety glasses or goggles when removing or installing retaining rings. Retaining rings can slip from the pliers and could be propelled with enough force to cause serious eye injury. (00312a)

2. See Figure 2. Remove retaining ring from pivot pin groove at bottom of master cylinder bracket. Save the pivot pin for re-use, discard the retaining ring.
3. Remove pivot pin and brake hand lever from master cylinder assembly.

NOTE

Do not remove the handlebar clamp or switch housing assembly to remove the brake lever.

Installing the Brake Lever

NOTE

Follow the instructions in Steps 4 and 5 carefully in order to prevent the actuating tab on the brake lever from damaging the rubber boot and plunger of the front stoplight switch.

1. Gently press and hold the piston cap (A) forward with a screwdriver. Slip the brake lever into position and align the pivot pin holes.
2. If it is not already in place, insert the pivot lever bushing from the kit into the new brake lever (1). Slip the brake lever into position and align the pivot pin holes.
3. Check the front brake for proper operation. There should be no free play in the hand lever. A slight preload is permissible.

▲ WARNING

Be sure the master cylinder relief port is not plugged. A plugged relief port can cause brake drag or lockup and loss of vehicle control, which could result in death or serious injury. (00317a)

4. To verify proper operation of the master-cylinder relief port, actuate the brake lever with the reservoir cover and gasket removed. A slight spurt of fluid will break the surface if internal components are working properly.
5. Reinstall the master cylinder cover.

▲ WARNING

Be sure that all lights and switches operate properly before operating motorcycle. Low visibility of rider can result in death or serious injury. (00316a)

6. Check that the stop light goes on when the brake lever is actuated.

CLUTCH LEVER INSTALLATION

See the CLUTCH CONTROL section of the appropriate Service Manual for all clutch lever removal, installation and adjustment procedures.

SERVICE PARTS

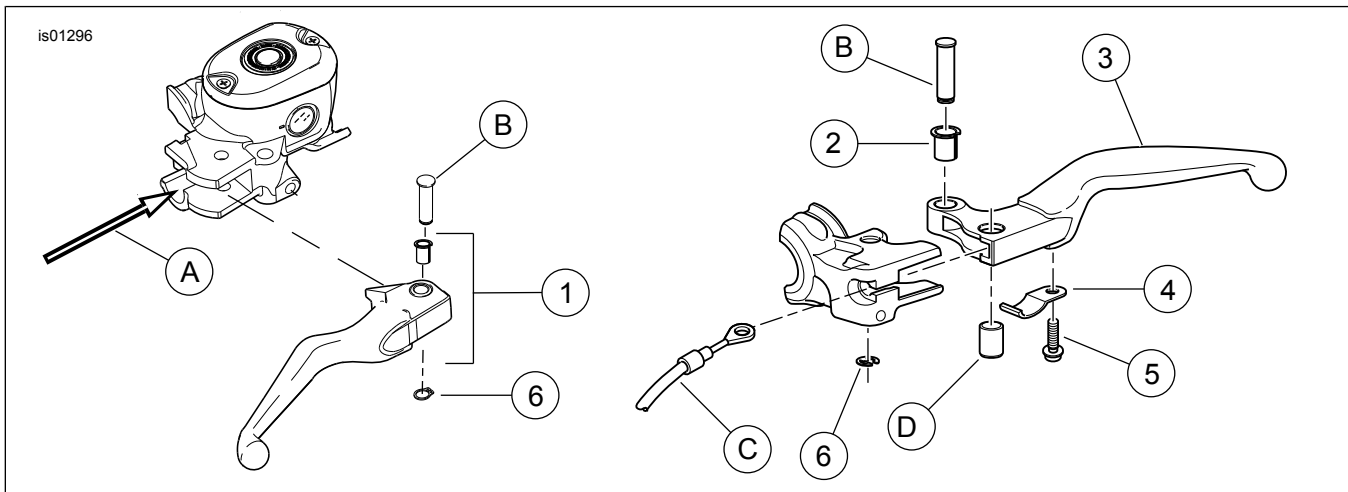

Figure 2. Service Parts: XL Hand Lever Kit

Table 1. Service Parts:; XL Hand Lever Kit

Item	Description (Quantity)	Part Number
1	Lever assembly, front brake control (includes bushing) - chrome	44993-04
	Lever assembly, front brake control (includes bushing) - black	46946-06A
2	Bushing, clutch lever	45801-04
3	Lever clutch - chrome	45035-07
	Lever clutch - black	46945-07A
4	Spring, anti-rattle	45799-04
5	Screw, anti-rattle	45800-04
6	Retaining ring	11379
Items mentioned in text, but not included in kit:		
A	Press piston cap forward	
B	Original equipment pivot pin	42807-04
C	Clutch cable	
D	Clutch cable anchor pin	46268-04