



INSTRUCTIONS

J04367

2008-10-21



TRIBAL BRAKE PEDAL PAD KIT

GENERAL

Kit Number

42008-09

Models

For model fitment information, see the P&A Retail Catalog or the Parts and Accessories section of www.harley-davidson.com (English only).

Kit Contents

See Figure 1 and Table 1.

INSTALLATION

NOTE

A service manual for your motorcycle is available at your Harley-Davidson Dealer.

1. Remove the previously installed brake pedal cover from the foot brake lever. Discard pedal cover.
2. Align the assembly over the foot brake pedal and insert the threaded stud through the hole in the pedal.
3. Obtain the washer (3) and locknut (2) from the kit and secure the pedal pad assembly to the foot brake pedal.
4. Tighten the locknut to 2.5 N·m (33 in-lbs).

NOTE

Whenever the motorcycle brake components are serviced, always test it on dry, clean pavement at low speeds before putting the vehicle into regular service.

SERVICE PARTS

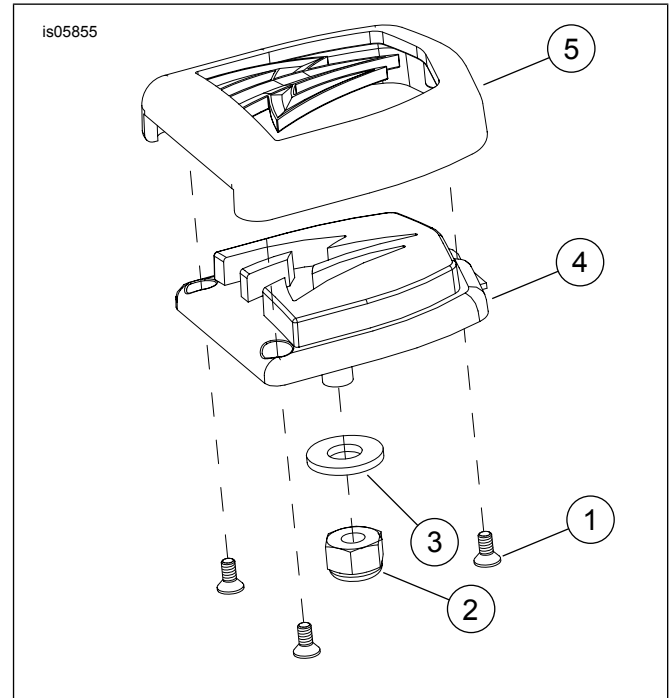

Figure 1. Service Parts: Tribal Brake Pedal Pad Kit

Table 1. Service Parts

Item	Description (Quantity)	Part Number
1	Screw, 4-40 x 1/4 inch (3)	4277
2	Locknut	7686
3	Washer	6703
4	Tread, brake pedal pad	Not Sold Separately
5	Cover, brake pedal pad	Not Sold Separately

