



INSTRUCTIONS

J04005

2007-08-06



ROAD TECH QUEST GLOBAL POSITIONING SYSTEM (GPS) CRUISING MOUNT KIT

GENERAL

Kit Number

92300-06A

Models

This kit is required when using any of the Road Tech™ Quest™ GPS units listed in Table 1 on specific model motorcycles.

For model fitment information, please see the P&A Retail Catalog or the Parts and Accessories section of www.harley-davidson.com (English only).

Table 1. Models

GPS Cruising Kit Part Number	Usage
Road Tech Quest 92313-06	North America
Road Tech Quest 92311-06	Europe

This kit **IS NOT** compatible with:

- Auxiliary Accessory Switch Housing Kits (left side) 70213-02A or 70248-02.
- Hand lever bracket clamp-mounted clock 75041-03 or 75042-03, OR thermometer 75102-04 or 75104-04, when mounted on the **clutch lever** bracket.
- Road Tech™ XM Satellite Radio Receiver Kit, Part Number 76390-05.

Additional Parts Required

Loctite® 271 (Red) Threadlocker and Sealant (H-D Part Number 99671-97) is required for proper installation of this kit.

FLTRI (Road Glide®) models: will require the separate purchase of an Audio Cable (Part Number 92335-06).

The above items are available from a Harley-Davidson dealer.

⚠ WARNING

Rider and passenger safety depend upon the correct installation of this kit. Use the appropriate service manual procedures. If the procedure is not within your capabilities or you do not have the correct tools, have a Harley-Davidson dealer perform the installation. Improper installation of this kit could result in death or serious injury. (00333b)

NOTE

This instruction sheet references Service Manual information. A Service Manual for your model motorcycle is required for this installation and is available from a Harley-Davidson Dealer.

Electrical Overload

NOTICE

It is possible to overload the vehicle's charging system by adding too many electrical accessories. If the combined electrical accessories operating at any one time consume more electrical current than the vehicle's charging system can produce, the electrical consumption can discharge the battery and cause damage to the vehicle's electrical system. (00211d)

⚠ WARNING

When installing any electrical accessory, be certain not to exceed the maximum amperage rating of the fuse or circuit breaker protecting the affected circuit being modified. Exceeding the maximum amperage can lead to electrical failures, which could result in death or serious injury. (00310a)

The Road Tech Quest requires up to **210 milliamps** additional current from the electrical system.

Kit Contents

See Table 2, Table 3 and Figure 4.

MOUNTING BRACKET AND PLATE INSTALLATION

NOTE

Do not use solvent-based chemicals or waxes directly on the plastic or rubber components as they can affect the overall performance and appearance of the plastic and rubber.

Models WITH Maxi® Fuse:

⚠ WARNING

To prevent accidental vehicle start-up, which could cause death or serious injury, remove main fuse before proceeding. (00251b)

1. Refer to the Service Manual and follow the instructions given to remove the Maxi® Fuse.

Models WITHOUT Maxi® Fuse:

⚠ WARNING

To prevent accidental vehicle start-up, which could cause death or serious injury, disconnect battery cables (negative (-) cable first) before proceeding. (00307a)

⚠ WARNING

Disconnect negative (-) battery cable first. If positive (+) cable should contact ground with negative (-) cable connected, the resulting sparks can cause a battery explosion, which could result in death or serious injury. (00049a)

1. Refer to the Service Manual and follow the instructions given to remove the seat (and the airbox cover on VRSC models). Disconnect the battery cables, negative (-) cable first. Retain all seat mounting hardware.

⚠ WARNING

When servicing the fuel system, do not smoke or allow open flame or sparks in the vicinity. Gasoline is extremely flammable and highly explosive, which could result in death or serious injury. (00330a)

2. **ALL models:** Refer to FUEL TANK, REMOVAL (Carbureted or EFI Engine) in the Service Manual and follow the instructions given to remove the fuel tank.
3. See Figure 4. Obtain the mounting bracket (1), auxiliary jack plug (2) and pan head screw (3) from the Cruising Mount Kit.
4. Position the jack plug to the back of the bracket as shown, and orient so the plug will reach around the edge of the bracket to the jack connector on the front. Fasten with the pan head screw, and tighten securely.
5. Remove and discard the original equipment clutch lever clamp mounting screws.
6. Obtain the two button-head screws (4) and spacers (5) from the Cruising Mount Kit.
7. Insert the button-head screws into the mounting bracket as shown, through the holes above and below the slot. Place a spacer over the threads of each screw. Insert the screw threads into the holes in the clutch lever clamp removed earlier.
8. Adjust the hand lever position for rider comfort and posture, then tighten the screws to 6.8–9 N·m (60–80 in-lbs).
9. Obtain the Road Tech Quest harness (29) from the **Cruising GPS Kit**.
10. Apply a drop of Loctite® 271 (Red) Threadlocker and Sealant (H-D Part Number 99671-97, available separately) to the threads of the 3.5mm audio jack connector (E) on the Road Tech Quest harness. Thread the audio jack connector into the tapped hole (G) in the mounting bracket from the back side, and tighten securely.
11. Press the rubber jack plug (2) into the opening in the audio jack connector.
12. Obtain the mounting ball (6), lock nut (7) and lower ball clamp (8) from the Cruising Mount Kit.

13. Insert the mounting ball stud through the holes in the lower ball clamp and mounting bracket. Thread the lock nut onto the stud from behind the mounting bracket, and tighten securely.
14. Obtain the mounting plate (10), upper ball clamp (9) and three flat head screws (11) from the Cruising Mount Kit.
15. Insert the screws into the mounting plate and upper ball clamp as shown. Place the upper ball clamp over the mounting ball, lining up the holes with those in the lower ball clamp. Thread the screws into the lower ball clamp, position the mounting plate to a suitable viewing angle and tighten the screws to 4–6.8 N·m (3–5 ft-lbs).

HARNES ROUTING AND CONNECTION

NOTE

Route the Road Tech Quest harness along the outside of the handlebar, even on internally-wired handlebars.

1. Route the unconnected end of the Road Tech Quest harness (29) as follows:
 - a. Follow the existing wiring from the left-side handlebar switches over to the center of the handlebar. Use wire ties (22) from the kit to tie the harness in place as you route the harness along the handlebar to the center.
 - b. Route the wires down through the upper fork bracket (triple clamp), past the steering head, and back along the frame backbone toward the seat.
 - c. Locate the main harness chassis ground connection on the frame (or on the rear fork on some earlier XL models). See the Service Manual for your model and year vehicle for specific location. Remove the ground screw or nut.
 - d. Select the appropriate ring terminal (16 or 17) from the kit to fit the ground screw or stud.

⚠ WARNING

Be sure that steering is smooth and free without interference. Interference with steering could result in loss of vehicle control and death or serious injury. (00371a)

- Be sure wires do not pull tight when handlebars are turned fully to left or right fork stops.
2. Use wire ties from the kit to fasten the Road Tech Quest harness to the frame or harnesses along the vehicle frame backbone. Check to ensure that the harness wires do not pull tight when the handlebars are turned fully to the left or right fork stops. Cut the black wire on the Road Tech Quest harness to easily reach the ground location, and crimp the ring terminal to the end of the wire according to the crimping tool instructions in the Service Manual.
 3. Install the ring terminal to the ground connection, and secure per the torque specification in the Service Manual.

Butt splicing is a necessary step in the installation of the satellite receiver to the motorcycle. Refer to SEALED BUTT SPLICE CONNECTORS in the Service Manual for proper butt splicing procedures.

▲ WARNING

Be sure to follow manufacturer's instructions when using the UltraTorch UT-100 or any other radiant heating device. Failure to follow manufacturer's instructions can cause a fire, which could result in death or serious injury. (00335a)

- Avoid directing heat toward any fuel system component. Extreme heat can cause fuel ignition/explosion resulting in death or serious injury.
- Avoid directing heat toward any electrical system component other than the connectors on which heat shrink work is being performed.
- Always keep hands away from tool tip area and heat shrink attachment.

Connect the Red wire on the Road Tech Quest harness to a power source on the vehicle:

- **For 2004 and later Dyna models:** Go to Step 4.
 - **For 2004 and later Softail models:** Go to Step 5.
 - **For 2004 and later FL Touring models:** Go to Step 6.
 - **For 2004 and later VRSC or XL models, and ALL 2003 or earlier models:** Go to Step 7.
4. **For 2004 and later Dyna models:** See the Wiring Diagram for your model and the ELECTRICAL CADDY section of the Service Manual.
- a. Remove the electrical caddy from the vehicle per the Service Manual instructions.
 - b. Obtain the Orange/White fuse block adapter wire (18) from the kit. Note the terminal on each end (see Figure 1). Only the terminal **WITH the spring tabs** will fit into the fuse cavity. Carefully cut the terminal **WITHOUT** spring tabs from the wire and discard it.
 - c. Locate the fuse cavity indicated as "OPEN" on the electrical caddy. There should be a wire feeding one side of this circuit, but no mating wire or fuse will be present. Insert the terminal on the Orange/White adapter wire until it stops. Refer to a nearby factory-installed terminal for comparison to ensure proper orientation and depth.
 - d. Cut the excess length from the Red wire **on the Road Tech Quest harness** to within easy reach of the Orange/White adapter wire installed in Step 4c. Refer to the warning after Step 3, and the SEALED BUTT SPLICE CONNECTORS section of the Service Manual. Using the **blue** butt-splice connector (20) from the kit, splice the Red wire from the Road Tech Quest harness to the Orange/White adapter wire.
 - e. See Figure 4. Install one of the 2 Amp fuses (21) from the kit into the OPEN fuse cavity to complete the circuit.
 - f. Re-install the electrical caddy and cover onto the vehicle per the instructions in the ELECTRICAL CADDY section of the Service Manual.
 - g. Proceed to Step 8.

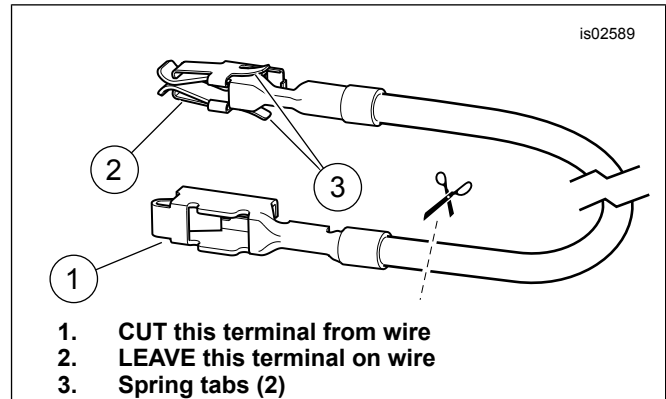

Figure 1. Fuse Block Adapter Wire (Dyna and Softail)

5. **For 2004 and later Softail models:** See the Wiring Diagram for your model and the FUSES section of the Service Manual.
- a. Remove the fuse block cover. Remove the two hex head screws fastening the fuse block bracket, and pull the bracket and fuse block assembly away from the motorcycle frame.
 - b. Depress the tab retaining the left-hand fuse block, and slide the block out of the mounting slots.
 - c. Obtain the Orange/White fuse block adapter wire (18) from the kit. Note the terminal on each end (see Figure 1). Only the terminal **WITH the spring tabs** will fit into the fuse cavity. Carefully cut the terminal **WITHOUT** spring tabs from the wire and discard it.
 - d. Locate the fuse cavity indicated as "P&A IGN" on the fuse block cover. There should be a wire feeding one side of this circuit, but no mating wire or fuse will be present. Insert the terminal on the Orange/White adapter wire until it stops. Refer to a nearby factory-installed terminal for comparison to ensure proper orientation and depth.
 - e. Cut the excess length from the Red wire **on the Road Tech Quest harness** to within easy reach of the Orange/White adapter wire installed in Step 5d. Refer to the warning after Step 3, and the SEALED BUTT SPLICE CONNECTORS section of the Service Manual. Using the **blue** butt-splice connector (20) from the kit, splice the Red wire from the Road Tech Quest harness to the Orange/White adapter wire.
 - f. See Figure 4. Install one of the 2 Amp fuses (21) from the kit into the P&A IGN fuse cavity to complete the circuit.
 - g. Slide the fuse block into the mounting slots in the fuse block bracket until it clicks firmly into place. Place the bracket and fuse block assembly into position, and fasten with the two hex head screws removed earlier. Tighten securely. Re-install the fuse block cover.
 - h. Proceed to Step 8.

6. **For 2004 and later FL Touring models:** See the Wiring Diagram for your model and the SYSTEM FUSES section of the Service Manual.

a. **For 2004 through 2006 models, and for 2008 and later models:** Remove the left-hand side cover per the Service Manual instructions. **For 2007 models only:** Remove the right-hand side cover per the Service Manual instructions.

b. **ALL models:** Remove the Maxi Fuse holder, fuse block and dust cover from the vehicle per the Service Manual instructions.

c. Obtain the Orange/White fuse block adapter wire (18) from the kit. **For 2004 through 2006 models, and for 2008 and later models:** Note the terminal on each end (see Figure 2). Only the terminal **WITHOUT** the spring tabs will fit into the fuse cavity. Carefully cut the terminal **WITH** spring tabs from the wire and discard it. **For 2007 models only:** Note the terminal on each end (see Figure 3). Only the terminal **WITH** the spring tabs will fit into the fuse cavity. Carefully cut the terminal **WITHOUT** spring tabs from the wire and discard it.

d. **ALL models:** Locate the fuse cavity indicated as "P&A IGN" "2A MAX". There should be a wire feeding one side of this circuit, but no mating wire or fuse will be present. Remove the three existing fuses in this row, noting their location.

e. Gently remove the orange plastic secondary lock from the fuse block. Insert the terminal on the Orange/White adapter wire until it stops. Refer to a nearby factory-installed terminal for comparison to ensure proper orientation and depth. Re-install the secondary lock.

f. Cut the excess length from the Red wire **on the Road Tech Quest harness** to within easy reach of the Orange/White adapter wire installed in Step 6e. Refer to the warning after Step 3, and the SEALED BUTT SPLICE CONNECTORS section of the Service Manual. Using the **blue** butt-splice connector (20) from the kit, splice the Red wire from the Road Tech Quest harness to the Orange/White adapter wire.

g. See Figure 4. Install one of the 2 Amp fuses (21) from the kit into the P&A IGN fuse cavity to complete the circuit. Re-install the three fuses removed in Step 6d into the proper cavities.

h. Install the dust cover onto the fuse block, and install the fuse block and Maxi Fuse holder per the instructions in the Service Manual.

i. Proceed to Step 8.

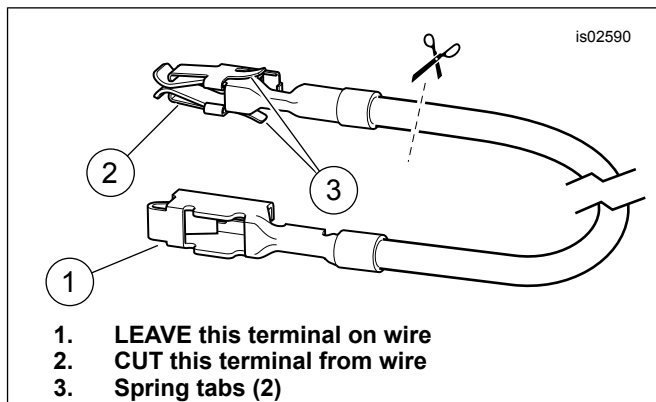

Figure 2. Fuse Block Adapter Wire (2004-2006 FL Touring) (2008 and Later FL Touring)

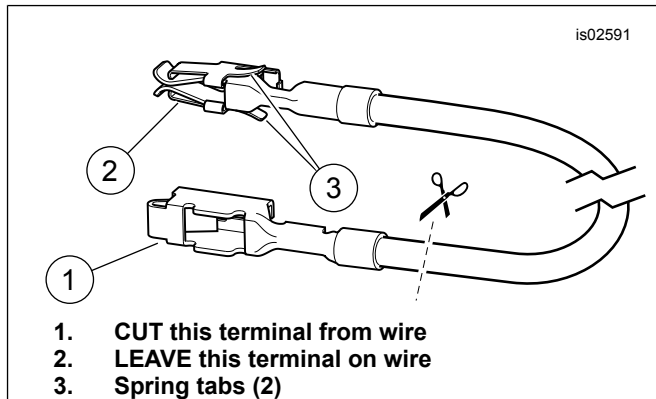

Figure 3. Fuse Block Adapter Wire (2007 FL Touring)

7. **For 2004 and later VRSC or XL models, and ALL 2003 or earlier models:** See the Wiring Diagram for your model in the Service Manual.

a. **All models except VRSC:** Locate the Orange/ White wire on the vehicle harness that leads to the rear lighting connector [7] under the seat. **VRSC models:** Locate the Orange/White wire on the vehicle harness that leads to the HDI position lamp [29].

b. Cut the **vehicle harness** Orange/White wire in a location that will allow easy stripping and splicing to the Red wire on the **Road Tech Quest** harness.

c. Cut the excess length from the Red wire on the **Road Tech Quest** harness to within easy reach of the Orange/White vehicle harness wires cut in Step 7b.

d. See Figure 4, the warning after Step 3, and the SEALED BUTT SPLICE CONNECTORS section of the Service Manual. Using the **red** butt-splice connector (19) from the kit, splice the Red wire together with the Orange/White wires cut in step 7b.

e. Proceed to Step 8.

8. **All models:** Open the cover of the fuse holder on the Road Tech Quest harness. Plug the remaining 2 Amp fuse (21) from the kit into the fuse holder, and close the cover.

9. Check along the entire length of the wiring for rubbing, chafing or pinch points.

CRADLE MOUNT INSTALLATION

1. Obtain the cradle mount (26), one short (28) and two long (27) flat-head screws from the the GPS Cruising Kit.
2. Position the cradle mount to the mounting plate (10). Insert the shorter screw through the right-side hole in the cradle and into the right-side threaded hole in the mounting plate, but do not fully tighten.
3. Insert the longer screws into the two remaining holes in the cradle and into the mounting plate holes. Alternately tighten the three screws securely.
4. Plug the round 4-pin DIN connector (F) on the Road Tech Quest harness into the back of the cradle through the opening in the back of the mounting plate.

FINAL ASSEMBLY

⚠ WARNING

When servicing the fuel system, do not smoke or allow open flame or sparks in the vicinity. Gasoline is extremely flammable and highly explosive, which could result in death or serious injury. (00330a)

1. Install the fuel tank. Refer to FUEL TANK, INSTALLATION (Carbureted or EFI Engine) in the Service Manual.
2. Verify that the Ignition/Light Key Switch is in the OFF position. **Models WITH Maxi Fuse:** Refer to the Service Manual and follow the instructions given to re-install the Maxi Fuse. **Models WITHOUT Maxi Fuse:** Connect the battery cables, positive (+) cable first. Refer to BATTERY CABLES in the Service Manual. Apply a light coat of petroleum jelly or corrosion retardant material to the battery terminals.

⚠ WARNING

Connect positive (+) battery cable first. If positive (+) cable should contact ground with negative (-) cable connected, the resulting sparks can cause a battery explosion, which could result in death or serious injury. (00068a)

NOTICE

Do not over-tighten bolts on battery terminals. Use recommended torque values. Over-tightening battery terminal bolts could result in damage to battery terminals. (00216a)

SERVICE PARTS

Table 2. Service Parts, Cruising Mount Kit

Item	Description (Quantity)	Part Number
1	Bracket, Road Tech Quest mounting	92310-06A
2	Plug, auxiliary jack	76232-03
3	Screw, pan head, #6-32 x 3/16 in.	2555
4	Cap screw, button head, 1/4-20 x 1-1/2 in. (2)	2519
5	Spacer (2)	5854
6	Ball mount	92304-06
7	Nut, Nylock, 3/8-16	7667
8	Clamp, lower	92302-06
9	Clamp, upper	92303-06
10	Mounting plate, GPS	92306-06

⚠ WARNING

After installing seat, pull upward on seat to be sure it is locked in position. While riding, a loose seat can shift causing loss of control, which could result in death or serious injury. (00070b)

3. Install the seat following the instructions in the Service Manual.

ROAD TECH QUEST UNIT INSTALLATION TO CRADLE MOUNT

1. Obtain the Road Tech Quest unit (23) from the GPS Cruising Kit.
2. Rotate the antenna (A) on the Road Tech Quest unit upward **at least** 90 degrees. Slide out the locking lever (B) located on the right side of the cradle mount.
3. Position the Road Tech Quest unit above the cradle mount, aligning the slots (C) on the sides of the unit with the tabs (D) on the inside of the mount.
4. Slide the Road Tech Quest unit downward into the cradle mount until it snaps into place. Release the lever. The spring return should close the lever and secure the unit. Verify complete closure by gently pressing on the lever after releasing. Rotate the antenna back to horizontal.

ROAD TECH QUEST UNIT OPERATION

NOTE

Do not use solvent-based chemicals or waxes directly on the plastic or rubber components as they can affect the overall performance and appearance of the plastic and rubber.

Refer to the instructions that came with the Road Tech Quest.

ROAD TECH QUEST UNIT REMOVAL FROM CRADLE MOUNT

To remove the Road Tech Quest unit from the motorcycle when not in use or when leaving the vehicle unattended:

1. Rotate the antenna (A) on the Road Tech Quest unit upward **at least** 90 degrees. Slide out the locking lever (B) located on the right side of the cradle mount.
2. Pull the Road Tech Quest unit upward from the cradle mount.
3. Rotate the antenna down flush with the back of the unit.
4. Store the Road Tech Quest unit in the case (30) provided.

Table 2. Service Parts, Cruising Mount Kit

Item	Description (Quantity)	Part Number
11	Screw, flat head, #6-32 x 1-1/4 in. (3)	4239
12	Earphone Kit (includes items 13 and 14)	91771-04
13	• Earphone	Not sold separately
14	• Cable, extension	Not sold separately
15	Clip, adhesive-backed (3)	10271
16	Ring terminal, #18-22 AWG (1/4 in. stud)	9858
17	Ring terminal, #18-22 AWG (5/16 in. stud)	9859
18	Fuse block adapter wire	70329-04
19	Butt-splice connector, #18-20 AWG (red)	70585-93
20	Butt-splice connector, #14-16 AWG (blue)	70586-93
21	Fuse, blade type, 2A (2)	54305-98
22	Wire tie (10)	10006

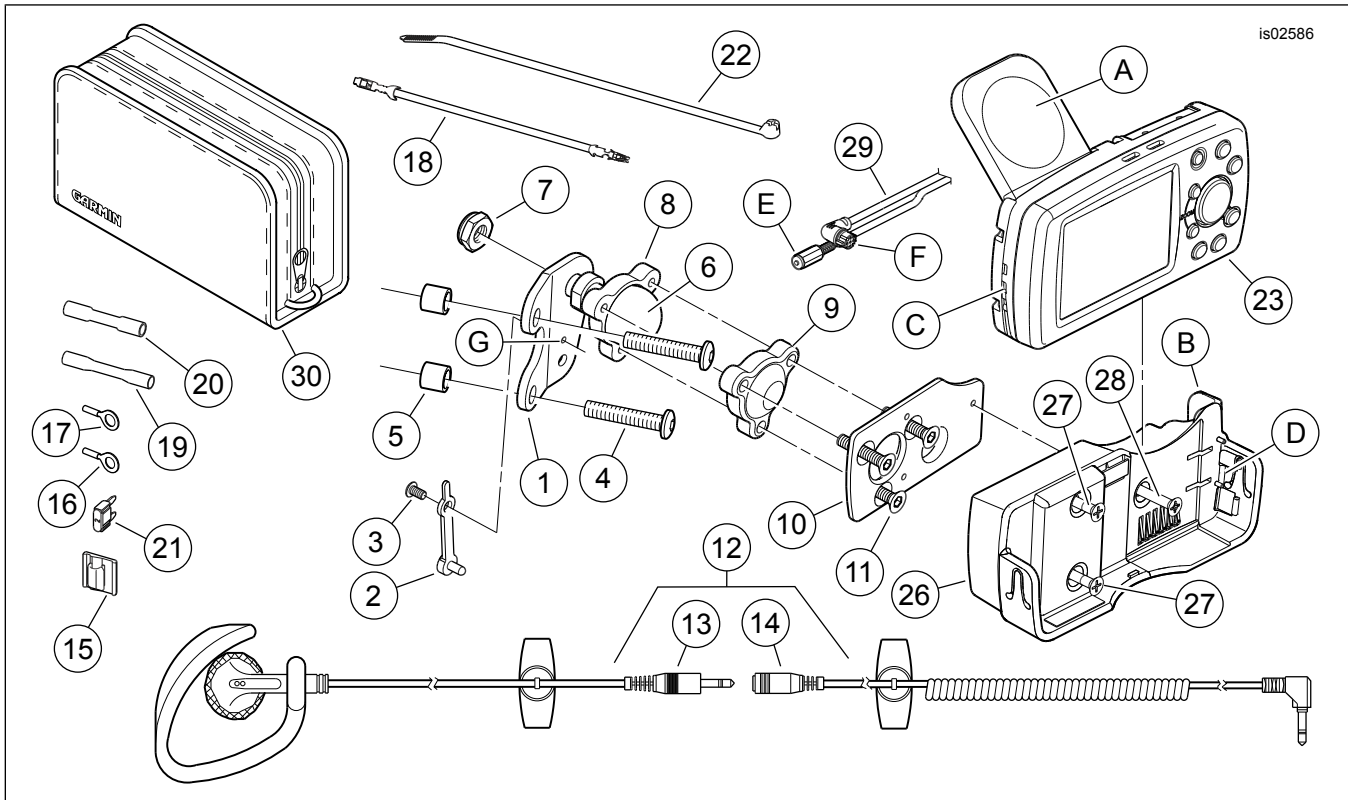

Figure 4. Service Parts, Cruising Mount and GPS Kits

Table 3. Service Parts, Road Tech Quest Cruising GPS Kit

Kit	Item	Description (Quantity)	Part Number
Kit 92313-06	23	Road Tech Quest unit (North America)	92107-05
Road Tech Quest Cruising GPS, North America	24	Software, city select (not shown)	76449-05
	25	A/C charger (not shown)	92146-05
Kit 92311-06	23	Road Tech Quest unit (Europe)	92105-05
Road Tech Quest Cruising GPS, Europe	24	Software, city select (not shown)	76450-05
	25	A/C charger (not shown)	76465-05
Items common to both kits	26	Cradle mount	92337-06
	27	Screw, flat head, #6-32 x 1-1/4 in. (2)	Not sold separately
	28	Screw, flat head, #6-32 x 1 in.	Not sold separately
	29	Harness assembly, Road Tech Quest	92309-06
	30	Carrying case	92147-05
	31	PCB/ USB cable (not shown)	92153-05
	32	User's manual, Road Tech Quest (not shown)	99753-05
33	Manual, map source (not shown)	99754-05	

Reference items mentioned in text:

Table 3. Service Parts, Road Tech Quest Cruising GPS Kit

Kit	Item	Description (Quantity)	Part Number
	A	GPS Antenna	
	B	Locking lever	
	C	Slots in Road Tech Quest unit	
	D	Tabs inside cradle mount	
	E	3.5 mm audio jack connector on harness	
	F	Round four-pin DIN connector on harness	
	G	Tapped hole in Road Tech Quest mounting bracket	