



INSTRUCTIONS

J04192

2006-05-18



LAYBACK LICENSE PLATE MOUNTING KIT

GENERAL

Kit Number

60193-07

Models

This kit fits all Harley-Davidson® motorcycle models having as original equipment a three-hole rear fender mounted license-plate bracket. The mount will hold license plates measuring a maximum of 7-1/4 x 4-1/4 inches (184 x 108 mm).

NOTE

Check for clearance before installing with a rear fender rack.

This kit DOES NOT FIT the following vehicles:

- FLSTS (Springer® Softail®)
- FXDS-CONV (Dyna Convertible™)
- 2000 through 2001 FXDX (Dyna Super Glide® Sport)
- FXDXT (Dyna Super Glide® T-Sport™)
- FL Touring models
- VRSC™ models
- Motorcycles with a "bobtail" rear fender
- models equipped with Rear Turn Signal Relocation Kit 68732-02A or 68733-02A

Kit Contents

See Figure 1.

INSTALLATION

1. Remove the license plate from the vehicle (if installed). Remove and discard the original equipment (O.E.) license-plate bracket and all bracket mounting hardware.
2. See Figure 1. Fasten the new license-plate holder to the rear fender:

- a. **For 2002 and later Dyna, AND 2004 and later Sportster models:** Insert the hole plug (8) into the hole in the fender to the left of the two lower license-plate mounting holes.
- b. **For all models EXCEPT Sportster:** Fasten the triangle gasket (3) and license-plate holder (1) to the fender using three **1/2-in. long** screws (4) and hex nuts with lock washers (6) from the kit. Tighten securely.

- c. **For Sportster models only:** Fasten the triangle gasket (3) and license-plate holder (1) to the fender using the **3/4-in. long** screw (5), flat washer (7), and a hex nut with lock washer (6) from the kit **in the TOP hole**. Do not fully tighten. Fasten the license-plate holder and gasket to the fender at the lower two holes using two 1/2-in. long screws (4) and two hex nuts with lock washers (6). Tighten all three screws securely.

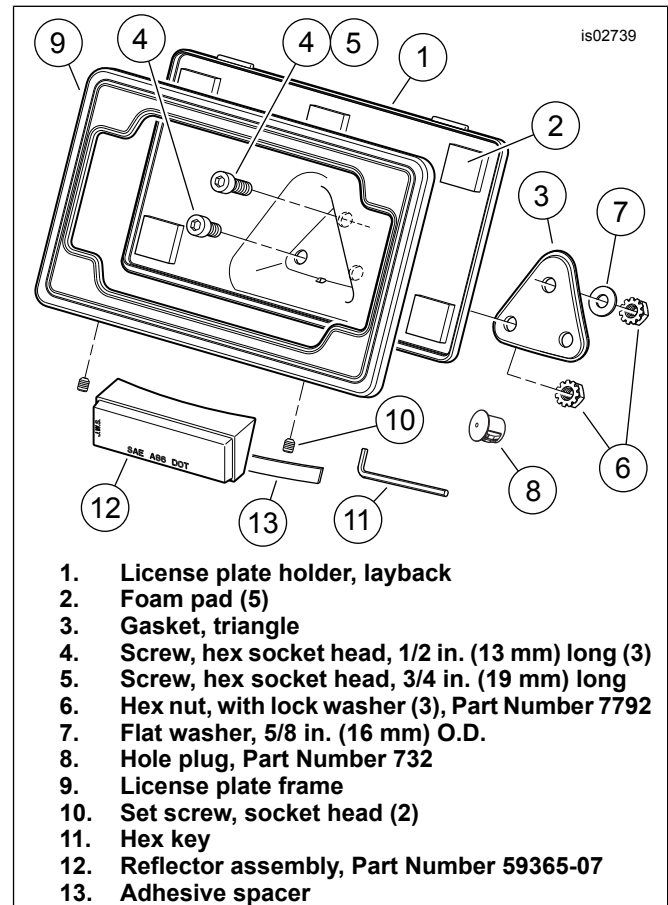

Figure 1. Layback License Plate Mount Components

3. Position the license plate onto the foam pads (2) of the license plate holder, centering and aligning the plate parallel to the holder edges for best appearance.

NOTE

Slots in the inside top edge of the license plate frame (9) fit over the two tabs on the top edge of the license plate holder.

4. Hook the top of the license plate frame over the top edge of the holder. Swing the bottom edge of the frame inward, holding the license plate in position against the pads.



5. Use the hex key (11) from the kit to securely fasten the license plate frame to the holder with the two socket head set screws (10).

NOTE

Ambient temperature should be **at least 60° F (16° C)** for proper adhesion of the reflector assembly (12) to the rear fender.

▲ WARNING

Federal Motor Vehicle Safety Standard (FMVSS) 108 requires motorcycles to be equipped with rear and side reflectors. Be sure rear and side reflectors are properly mounted. Poor visibility of rider to other motorists can result in death or serious injury. (00336b)

6. Clean the rear fender area beneath the tail lamp with a mixture of 50 to 70% isopropyl alcohol and 30 to 50% distilled water. Allow to dry thoroughly.

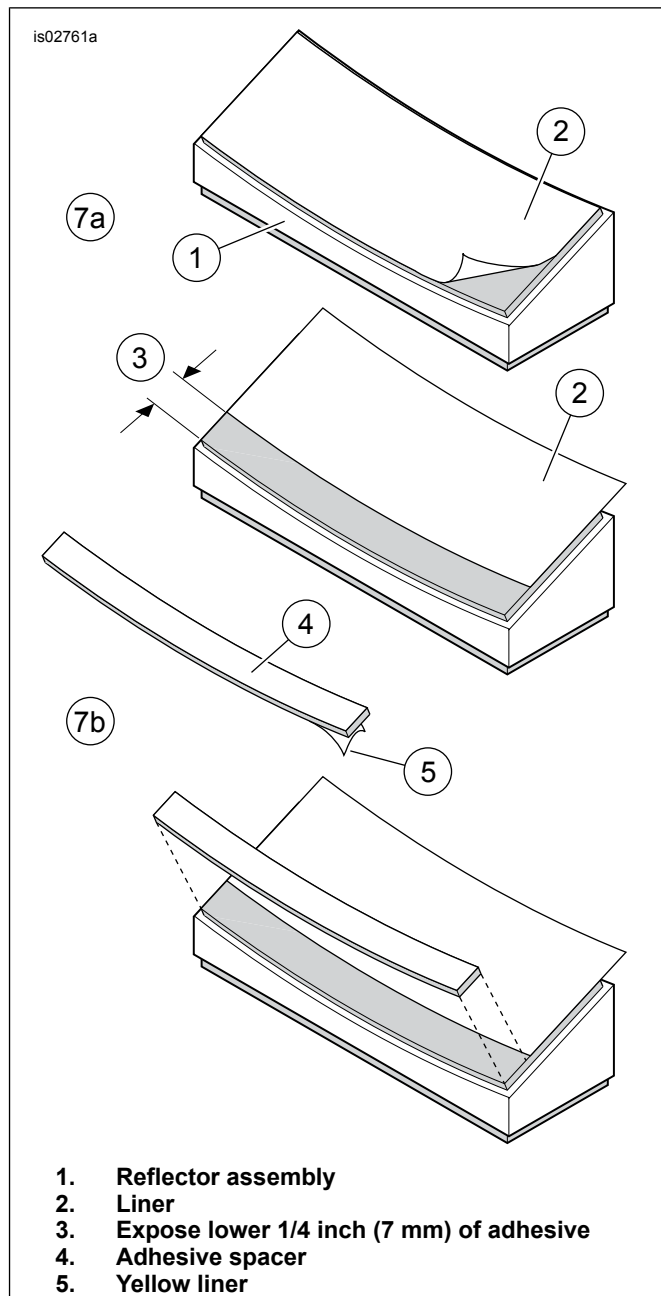

Figure 2. Installing Adhesive Spacer To Reflector (Dyna and Sportster Models Only)

7. **For Dyna and Sportster models only:** The adhesive spacer (13) must be added to the back of the reflector to position the reflector at the correct angle for optimal visibility.
 - a. See Figure 2. Peel the liner (2) from the adhesive surface of the reflector assembly (1). Re-position the liner to expose the lower 1/4 inch (7 mm) of adhesive (3).
 - b. Peel the yellow liner (5) from the adhesive spacer (4). Carefully position the spacer to the exposed adhesive surface of the reflector assembly, and press firmly into place.

8. **For ALL models:** Before removing the adhesive backing of the reflector assembly, test fit the reflector to the fender, centered from left to right, so the reflector surface is parallel to the face of the tail lamp lens.
 - a. Measure and lightly mark the centerline of the black reflector base, tail lamp lens, and the rear fender below the tail lamp with a wax pencil or water-based marker.
 - b. Use a straight-edge to find a location on the fender as indicated in the view in Figure 3 for your model motorcycle. Do not follow the curve of the fender, but measure straight down. Make a horizontal mark on the fender at this location.
 - c. Position the reflector to the rear fender, with the top of the black base at the horizontal mark. Verify that the reflector surface is parallel to the face of the tail lamp lens, adjusting the position of the reflector up or down slightly as necessary to become parallel. Mark the final location of the reflector on the fender.
 - d. Remove un-needed markings from the fender and reflector base, and clean any dirt or grease from the fender in the reflector mounting area.
9. Peel the liner from the adhesive backing of the reflector assembly (and the spacer if installed). Carefully position the reflector to the rear fender, and press firmly into place. Hold the reflector in position with steady pressure for five minutes to ensure proper adhesion.

NOTE

Allow **AT LEAST 24 hours** after applying the reflector before exposing the area to vigorous washing, strong water spray or extreme weather.

The adhesive bond will increase to maximum strength after about 72 hours at normal room temperature.

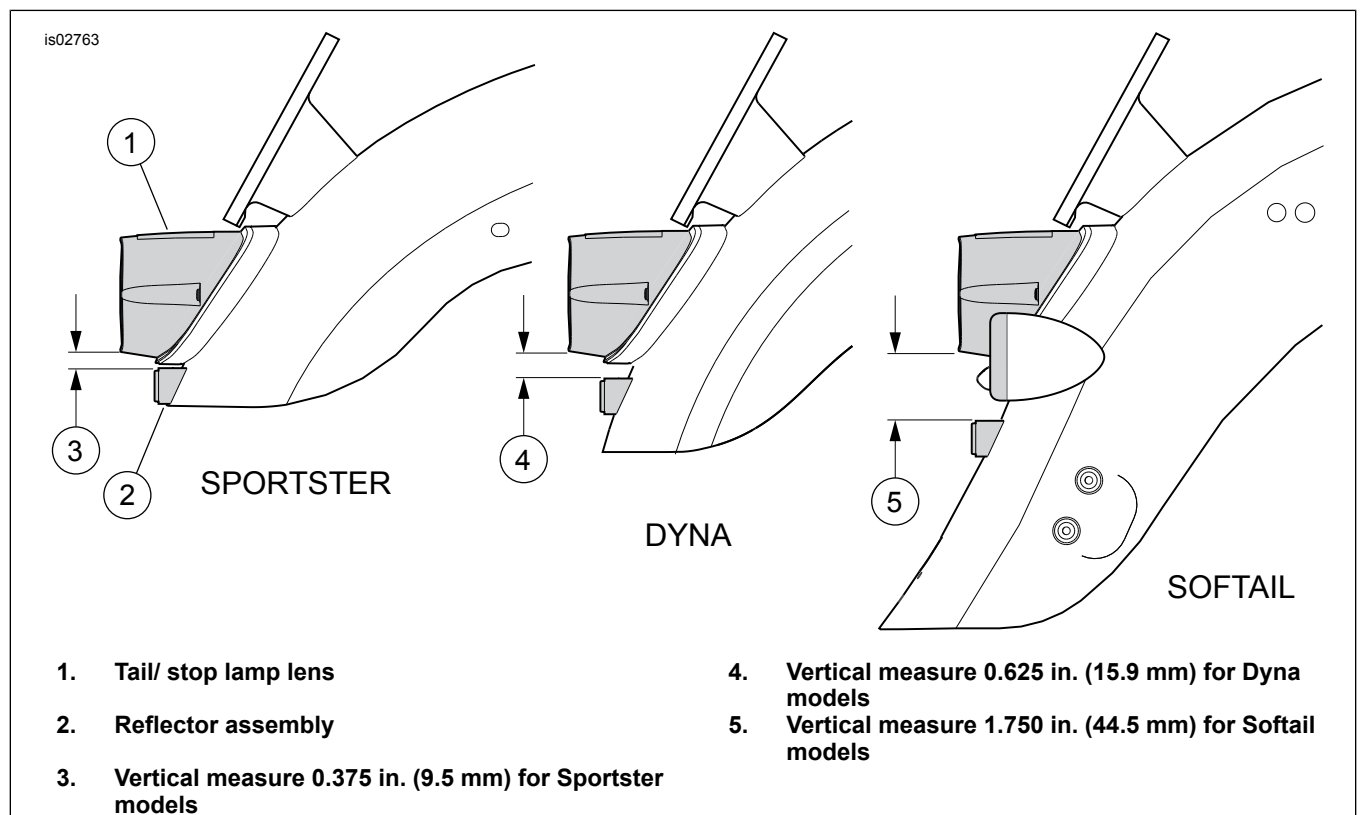

Figure 3. Reflector Mounting