



INSTRUCTIONS

J04006

2008-09-23



SPORTSTER FORWARD CONTROL KITS

GENERAL

Kit Numbers

33398-06A, 33395-06A, 33397-07A

Models

For model fitment information, see the P&A Retail Catalog or the Parts and Accessories section of www.harley-davidson.com (English only).

Additional Parts Required

XL1200L models require the purchase of footpegs (part numbers 33134-07CAZ and 33135-07CAZ).

⚠ WARNING

Rider and passenger safety depend upon the correct installation of this kit. Use the appropriate service manual procedures. If the procedure is not within your capabilities or you do not have the correct tools, have a Harley-Davidson dealer perform the installation. Improper installation of this kit could result in death or serious injury. (00333b)

NOTE

This instruction sheet references service manual information. A service manual for your model motorcycle is required for this installation and is available from a Harley-Davidson Dealer.

Kit Contents

See Figure 6, Figure 7 and Table 1.

REMOVAL

Remove Stock Shift Lever and Footrest Assembly

1. See Figure 1. Loosen the shift lever retaining screw (2) securing the shift lever (1) to the shifter shaft. Slide the shift lever off the splined shaft. Remove shifter peg from lever and save for installation. Discard shift lever.
2. Remove the two socket head screws (4) securing the footrest bracket (3) to the frame and remove footrest. Discard screws.
3. See Figure 7. Firmly press hole plugs (1) into frame screw holes remaining from footrest removal.

4. See Figure 2 and Figure 3. Remove the retaining ring (1) from the clevis to free the footrest clevis pin (4). Remove the clevis pin and footrest (3) from the footrest support. Discard retaining ring, clevis pin, spring washer and footrest bracket. **For All Models Except XL1200L:** Save footrest for installation. **For XL883L and 1200N Models:** Remove and discard wear peg (6). **For XL1200L Models:** Discard footrest.

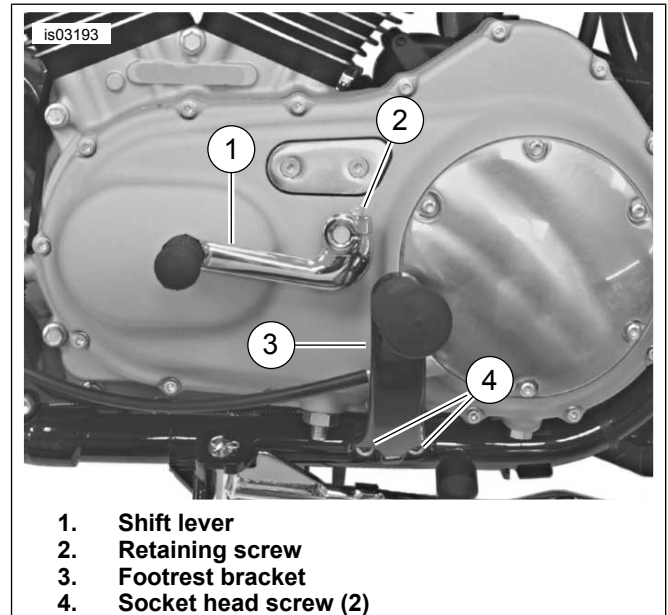

Figure 1. Remove Shift Lever and Footrest

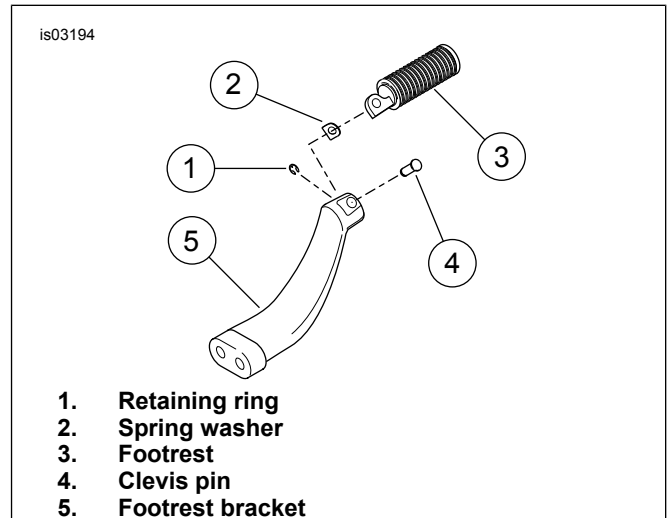

Figure 2. Remove Left Footrest - All Models except XL883L and XL1200N

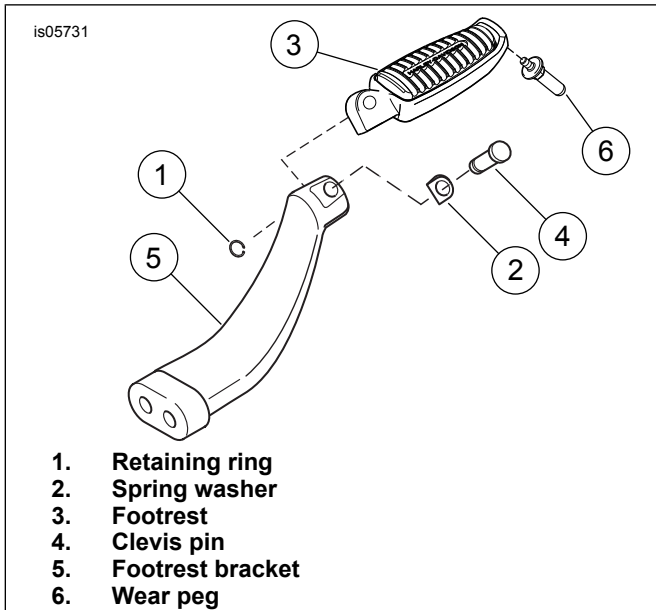

Figure 3. Remove Left Footrest - XL883L and XL1200N Models

Remove Stock Brake Pedal and Footrest Assembly

- See Figure 4. At the right footrest, remove the retaining ring (1) clevis pin (2), footrest (3) and spring washer. Discard all hardware. **For All Models Except XL1200L:** Save footrest for installation. **For XL883L and XL1200N Models:** Remove and discard wear peg (6). **For XL1200L Models:** Discard footrest.
- Remove the exhaust to access the brake rod (4). Follow the instructions in the service manual.
- Remove brake rod (4) from brake pedal and master cylinder bell crank. Discard brake rod.
- Remove the two screws (5) and right footrest/brake pedal support bracket with attached brake assembly from frame. Discard footrest support bracket and entire brake pedal assembly.
- See Figure 6 and Figure 7. Install hole plugs (1) in holes left from support bracket removal.

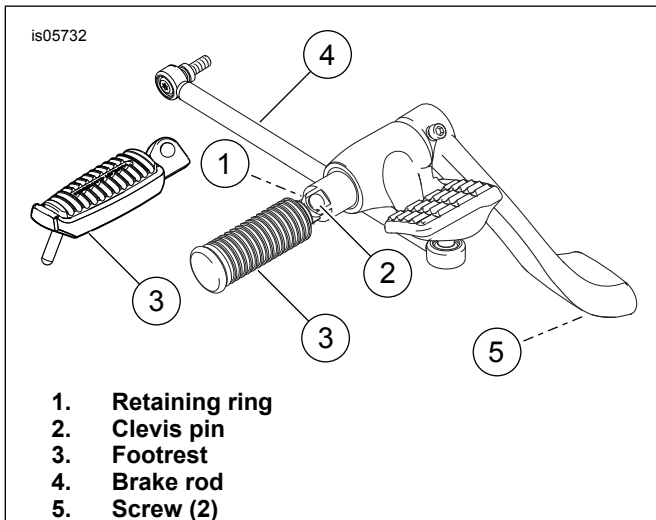

Figure 4. Remove Footrest Support Pedal and Brake Pedal

INSTALLATION

Install Forward Control Brake Pedal and Footrest Assemblies

- See Figure 6 and Figure 7. At the lower front of the right frame downtube, remove the two screws securing the J-clip (B) to the frame. Discard the screws but save J-clip for installation.
- Install the other end of the brake rod into the brake pedal assembly (8). Tighten to 9.5–16.3 N·m (84–144 in-lbs).

NOTE

Assemble the brake pedal and footpeg clevis onto the footrest support bracket (as described in the next step) prior to mounting the support bracket to the frame. This will allow easier installation of the footrest mount clevis retaining ring (installed to grooved end of footrest mount clevis).

- Slide the brake pedal (8) onto footrest mount clevis (11) then slide clevis into footrest/brake pedal support bracket (9). Align hole in the clevis with hole in the support bracket and install screw (6). Tighten the screw to 24.4–29.9 N·m (18–22 ft-lbs).
- Install the footrest mount clevis retaining ring (18) to the groove at the end of the footpeg clevis.
- Position the J-clip (from Step 1) against the frame aligning the mounting holes. Mount the footrest/brake pedal support bracket (9) and J-clip to frame using the **new** screws (3). Tighten the bracket to 61.1–67.9 N·m (45–50 ft-lbs).
- Obtain the brake rod (15) from kit and thread one end into the master cylinder bell crank. Tighten to 13.6–20.3 N·m (120–180 in-lbs).

▲ WARNING

Footrests must fold up and toward rear of motorcycle if struck. Failure to set footrests to fold up and back could result in death or serious injury. (00366a)

- For All Models:** Install footpeg on clevis with spring washer (2). Make sure spring washer is positioned inside clevis (11) with the square edge toward the inside. Align holes and push clevis pin (7) from top down through hole in clevis. Secure clevis pin using the **new** retaining ring (17). Footpegs must be installed so they fold up and back. **For XL1200L Models:** Install new footpegs and install wear peg (19). **For XL883L and XL1200N Models:** Install wear peg (19).
- Install exhaust following the instructions in the service manual.

Install Forward Control Shift Lever Assembly

- See Figure 6. Obtain shift link arm (13) and screw (6) from kit. Orient shift link arm pointing straight down and slide onto shift shaft (exiting engine side cover). Install screw (6) and tighten to 11–18 N·m (96–156 in-lbs).

2. Mount footrest/shift pedal support bracket (10) to frame using screws (3). Tighten to 61.1–67.9 N·m (45–50 ft-lbs).
3. Slide shift pedal (14) onto clevis (12). Mount clevis on footrest/shift pedal support bracket (10). Align hole in clevis with hole in support bracket and secure using screw (6). Tighten screw to 24.4–29.9 N·m (18–22 ft-lbs).
4. Install retaining ring (18) to the relief at the end of the clevis (12) to further secure it in place.
5. Install screw (4) in far end of the shift rod (16) and into shifter arm (13). Tighten to 13.6–20.3 N·m (120–180 in-lbs).
6. Install screw (5) in opposite end of shift rod (16) into shift lever (14). Tighten to 13.6–20.3 N·m (120–180 in-lbs).
7. Install shifter peg into **new** shift lever. Tighten securely.

▲ WARNING

Footrests must fold up and toward rear of motorcycle if struck. Failure to set footrests to fold up and back could result in death or serious injury. (00366a)

8. Install footpeg on clevis (12) with spring washer (2). Make sure spring washer is positioned inside clevis with the square edge toward the inside. Align holes and push clevis pin (7) from top down through hole in clevis. Secure clevis pin using the **new** retaining ring (17). Footpegs must be installed so they fold up and back. **For XL1200L Models:** Install new footpegs and install wear peg (19). **For XL883L and XL1200N Models:** Install wear peg (19).

Adjusting Shift Lever

If the gears do not engage fully or the toe shifter travel is incorrect, the shift linkage must be adjusted. See Figure 5.

SERVICE PARTS

Adjust the shift rod until the shift pedal is at 45 degrees as described.

1. See Figure 5. Remove screw (1) securing the ball joint (2) to shift pedal (5).
2. Turn ball joint or shift rod (4) to adjust rod length. Temporarily attach ball joint to shift pedal and check pedal angle. Make sure an equal number of threads are visible on both ends of shift rod.
3. When pedal angle is at 45 degrees, install screw (1). Tighten to 13.6–20.3 N·m (120–180 in-lbs).
4. Holding shift rod (4) so that it does not turn, tighten locknuts (3) on each end securely.

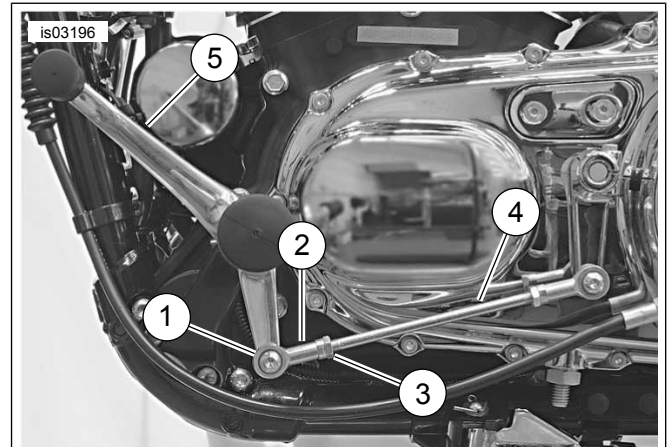

1. Screw (2)
2. Ball joint (2)
3. Lock nut (2)
4. Shift rod
5. Shift pedal

Figure 5. Adjusting Shift Pedal

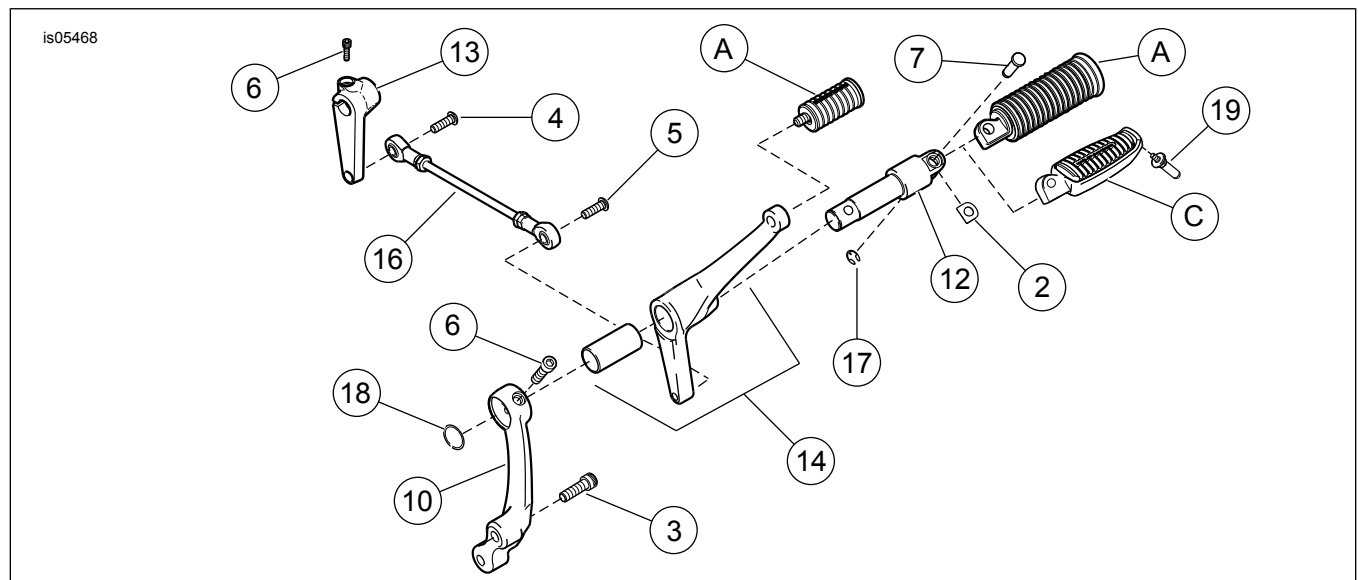

Figure 6. Service Parts: Forward Control, Left (Shift) Side

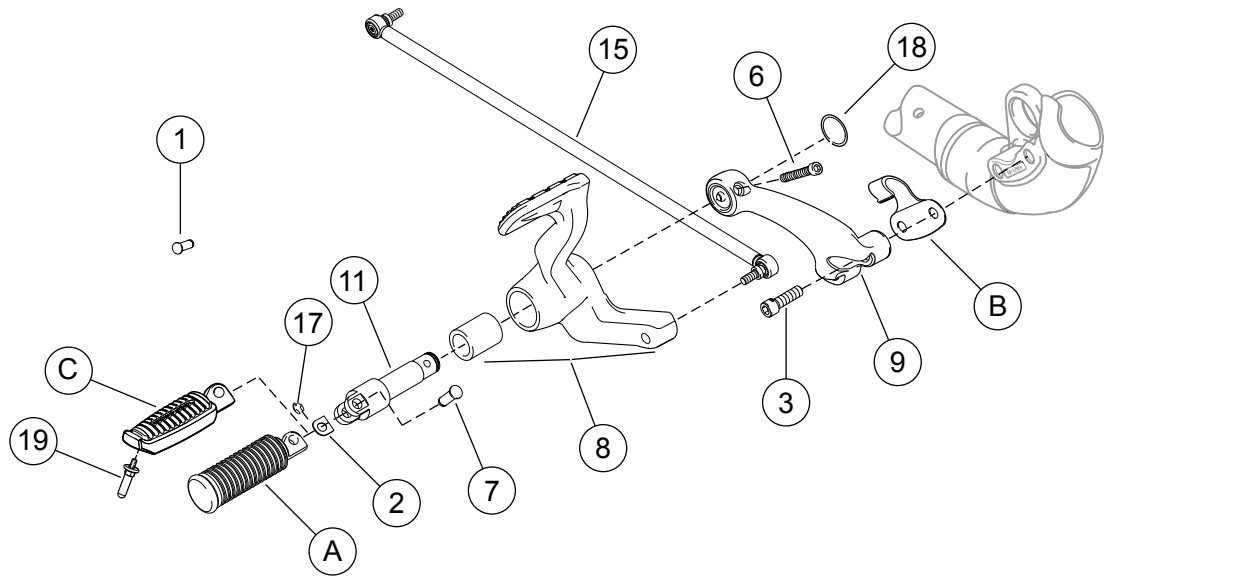

Figure 7. Service Parts: Forward Control, Right (Brake) Side

Table 1. Service Parts Table

Item	Description (Quantity)	Part Number
1	Plug, hole (4)	740
2	Washer, footpeg spring (2)	50912-72
3	Screw, 3/8-16 x 1-1/4 inch (4)	4748
4	Screw, 5/16-18 x 7/8 inch	4359
5	Screw, hex button (lock) 5/16-18 x 1 inch	4016
6	Screw, hex socket 5/16-18 x 1-1/4 inch (3)	3210A
7	Pin, footpeg clevis (2)	45041-01A
8	Assembly, brake pedal, chrome	42702-04
	Assembly, brake pedal, polished	42685-04
	Assembly, brake pedal, black	42649-07
9	Bracket, right rider footpeg support, chrome	42707-04
	Bracket, right rider footpeg support, black	42652-04
10	Bracket, left rider footpeg support, chrome	42706-04
	Bracket, left rider footpeg support, black	42651-04
11	Clevis footpeg right, chrome	42566-04
	Clevis footpeg right, black	42504-07
12	Clevis footpeg left, chrome	42541-04
	Clevis footpeg left, black	42503-07
13	Lever, shift shaft arm, chrome	34670-06
	Lever, shift shaft arm, black	34614-07
14	Assembly, shift lever, chrome	34650-04
	Assembly, shift lever, polished	34572-04
	Assembly, shift lever, black	34636-07
15	Assembly, brake rod	34581-04
	Assembly, brake rod, black	42645-07
16	Assembly, shift rod link	34573-04
	Assembly, shift rod link, black	34577-07
17	Ring, footpeg clevis pin retaining (2)	11304
18	Ring, footrest mount clevis retaining (2)	11390
19	Wear peg (2) (for XL883L and XL1200L Models only)	33188-08
Items mentioned in text, but not included in kit:		
A	Stock footrest	
B	Stock J-clip	
C	Stock footrest (XL883L Models only, separate purchase for XL1200L Models)	