



INSTRUCTIONS

J03929

2006-02-22



BILLET HEADLAMP WITH SHORT/TALL MOUNTS

GENERAL

Kit Number

68593-06, 69851-06

Models

Kit 68593-06 is a 5-3/4 inch headlamp and kit 69851-06 is a 4-1/2 inch headlamp. Both kits will fit the models listed in Table 1.

Table 1. Short and Tall Mount Kits

Kits	Models
Short Mount Kit 68595-06	1984-1999 FXSTC, 1998-Later FXST/B, and 2000-Later FXSTD; 1994-2005 FXDWG
Tall Mount Kit 69611-06	1996-Later XL 1200C and 1998-Later XL 883C; All 2006 Dyna Models; 1999-2000 FXR2/3/4

Additional Parts Required

This kit also requires the separate purchase of a Short or Tall Mounting Kit 68595-06 or 69611-06 for your model motorcycle, and can be purchased from a Harley-Davidson dealer.

▲ WARNING

Rider and passenger safety depend upon the correct installation of this kit. Use the appropriate service manual procedures. If the procedure is not within your capabilities or you do not have the correct tools, have a Harley-Davidson dealer perform the installation. Improper installation of this kit could result in death or serious injury. (00333b)

NOTE

This instruction sheet references Service Manual information. A Service Manual for your model motorcycle is required for this installation and is available from a Harley-Davidson dealer.

Kit Contents

See Figure 21, Table 2 and Figure 22, Table 3.

REMOVAL

Remove Headlamp and Mounting Bracket for Softail Models

▲ WARNING

To prevent accidental vehicle start-up, which could cause death or serious injury, disconnect negative (-) battery cable before proceeding. (00048a)

1. Disconnect negative (-) battery cable.
2. Remove fuel tank. Refer to FUEL TANK in Service Manual.
3. Disconnect 4-place headlamp connector [38] from main wire harness. Headlamp connector is located under fuel tank on left side.

NOTE

All Softails (except FXSTD) complete steps 4 through 6. For FXSTD models complete steps 7 through 9.

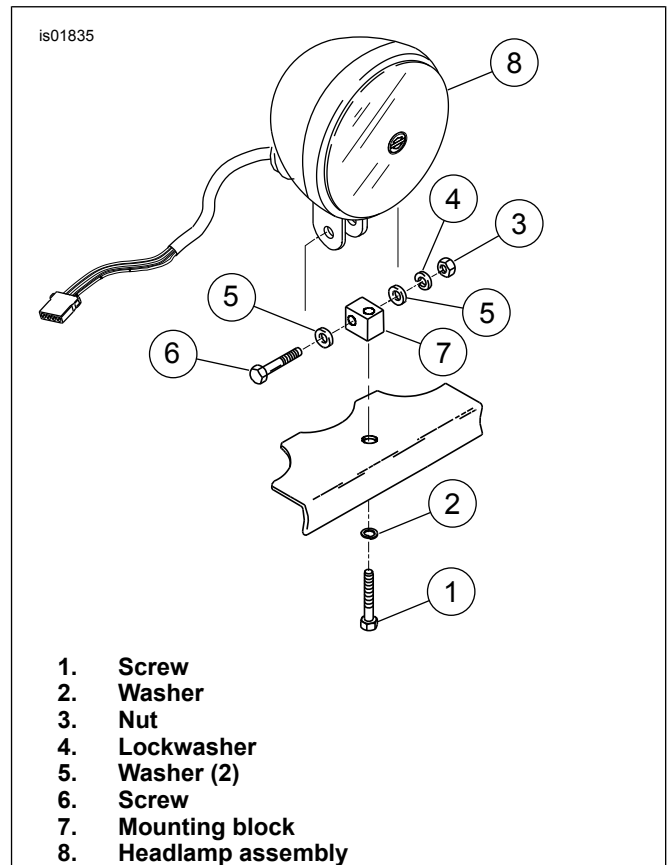

Figure 1. Softail and Dyna Headlamp Assembly with Mount (except FXSTD)

4. All Softails (except FXSTD): See Figure 1. Remove screw (1) and washer (2) from stem and bracket. Discard screw but save washer for later use.
5. Remove and discard mounting block (7) and headlamp assembly (8).



6. *FXSTD models:* See Figure 2. Remove screw (1) and washer (2) from stem and bracket. Save screw and washer for later use.
7. Remove and discard nut (3), washers (4), and screw (5).
8. Remove and discard mounting block (6) and headlamp assembly (7).

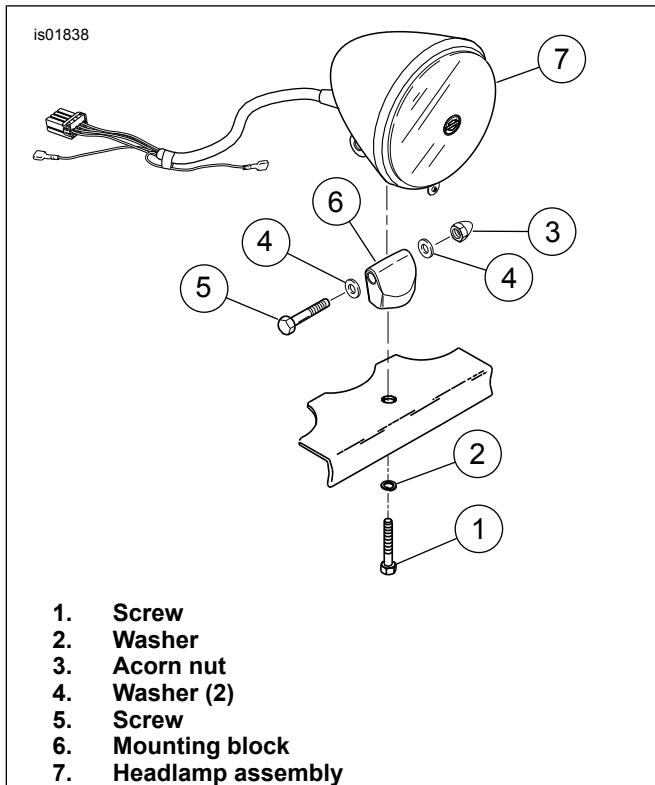

Figure 2. FXSTD Headlamp Assembly with Mount

Remove Headlamp and Mounting Bracket for Dyna Models

1. Remove seat following the instructions in the Service Manual.
2. Disconnect negative (-) battery cable.
3. Remove fuel tank. Refer to FUEL TANK in Service Manual.

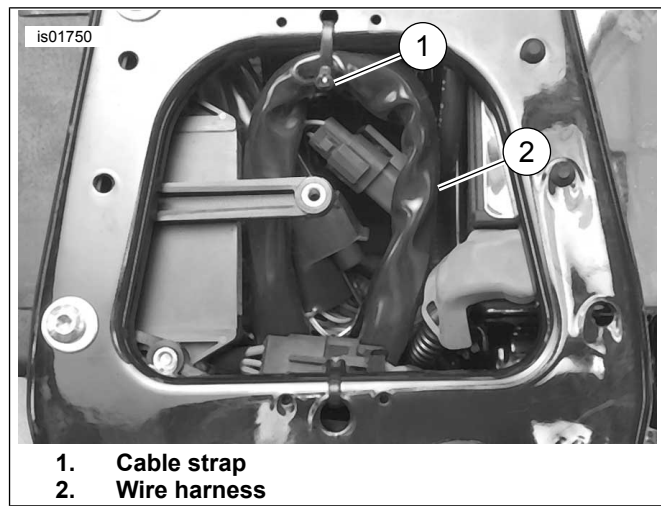

Figure 3. Dyna Service Loop (2005-Earlier)

4. *2005-Earlier FXDWG:* See Figures 3 and 4. Remove plug on right side of top frame tube. At service loop, remove cable clip and push wire harness into top frame tube. Pull connector out from hole on right side of tube. *2006-Later FXD:* See Figure 5. Remove cover under top frame tube, then pull connector out from opening under tube.
5. Disconnect 4-place headlamp connector [38] from main wire harness.

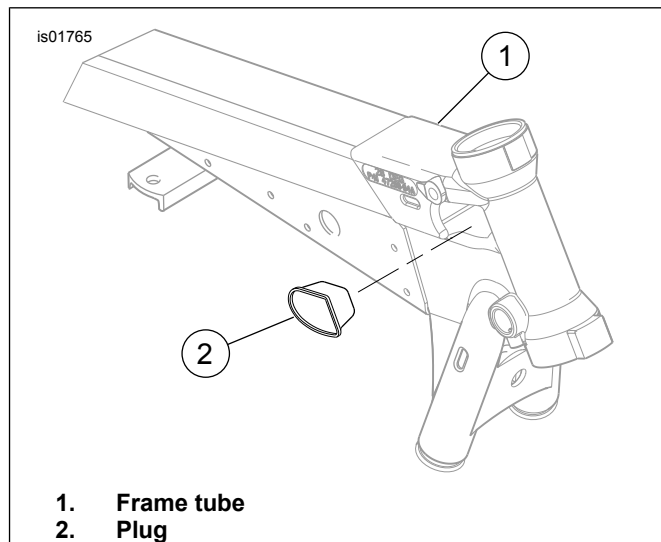

Figure 4. Dyna Top Frame Tube (2005-Earlier)

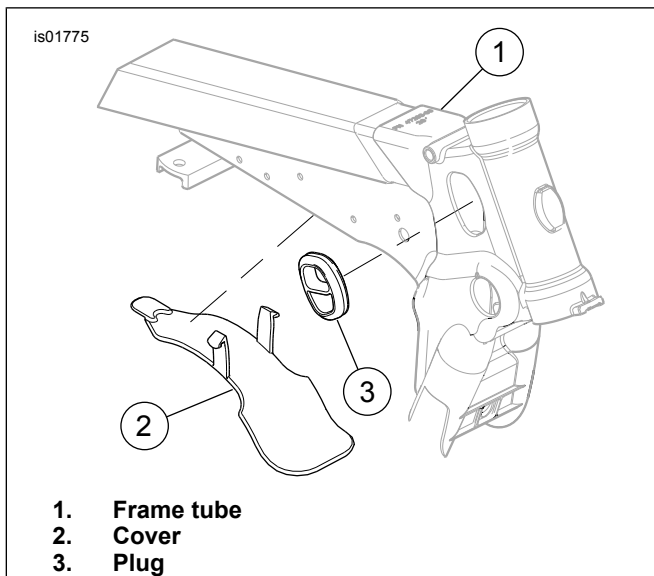

Figure 5. Dyna Top Frame Tube (2006-Later)

6. See Figure 1. Remove screw (1) and washer (2) from stem and bracket. *2005-Earlier FXDWG:* Discard screw but save washer for later use. *2006-Later FXD:* Save screw and washer for later use.
7. Remove and discard nut (3), washers (4), and screw (5).
8. Remove and discard mounting block (6) and headlamp assembly (7).

Remove Headlamp and Mounting Bracket for Sportster Models

1. Remove seat following the instructions in the Service Manual.
2. *2003-Earlier:* Disconnect negative (-) battery cable. *2004-Later:* Remove maxi-fuse. Refer to MAXI-FUSE in Service Manual.
3. Remove fuel tank. Refer to FUEL TANK in Service Manual.
4. Disconnect 4-place headlamp connector [38] from main wire harness. Headlamp connector is located under fuel tank.
5. See Figure 6. Remove screw (1) and washer (2) from stem and bracket. Save screw and washer for later use.
6. Remove and discard nut (3), washers (4), and screw (5).
7. Remove and discard mounting block (6) and headlamp assembly (7).

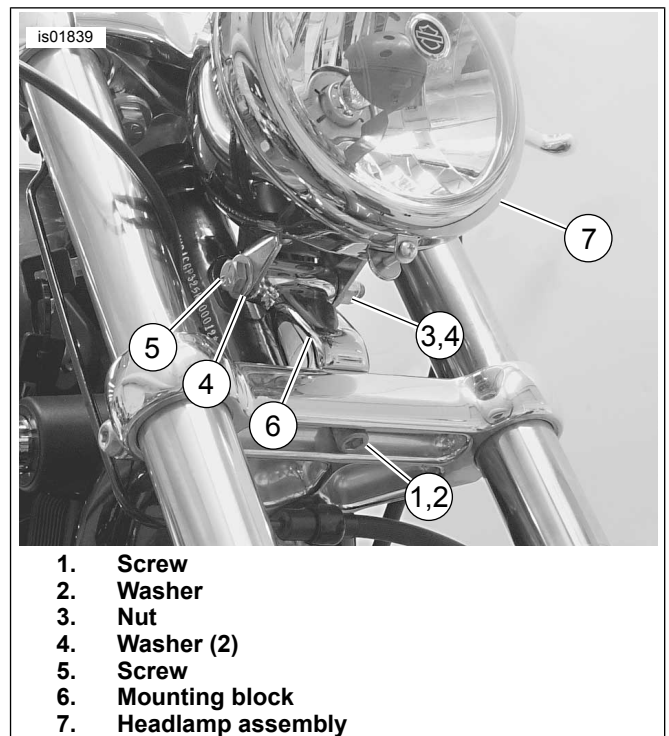

Figure 6. Sportster Headlamp Assembly with Mount

Remove Headlamp and Mounting Bracket for FXR Models

1. Remove seat following the instructions in the Service Manual.
2. Disconnect negative (-) battery cable.
3. Remove fuel tank. Refer to FUEL TANK in Service Manual.
4. Disconnect 4-place headlamp connector [38] from main wire harness. Headlamp connector is located under fuel tank on left side.
5. See Figure 7. Remove screw (1) and washer (2) from stem and bracket. Save screw and washer for later use.
6. Remove and discard nut (3), washers (4), and screw (5).
7. Remove and discard mounting block (6) and headlamp assembly (7).

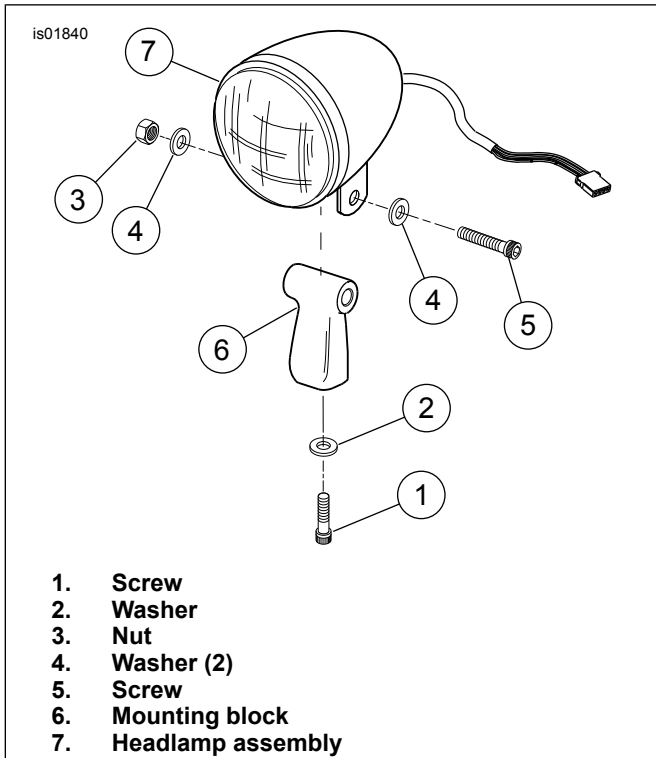

Figure 7. FXR Headlamp Assembly with Mount

INSTALLATION

Install Billet Headlamp with Short Mount

1. *Softail and 1994-2005 FXDWG Models:* See Figure 8. Loosely install vertical adjusting screw (1) from kit and washer (2) previously saved. *2000-Later FXSTD Models:* See Figure 8. Loosely install vertical adjusting screw (1) and washer (2) previously saved.
2. Loosely install mounting block (3) and billet headlamp (4) using horizontal adjusting screw (5), washers (6), lockwasher (7), and acorn nut (8).

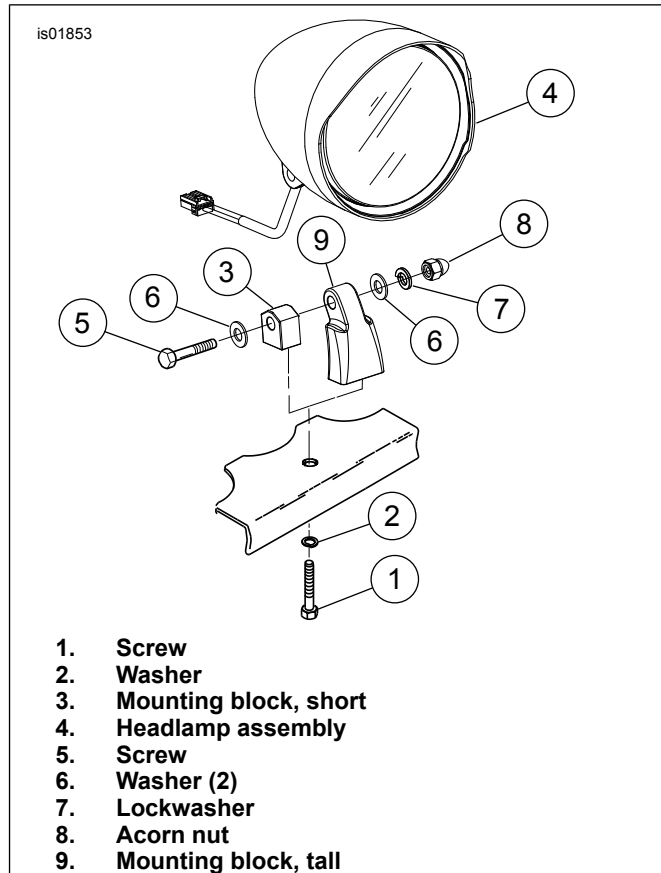

Figure 8. Billet Headlamp Assembly with Short/Tall Mounts

Install Billet Headlamp with Tall Mount

1. See Table 1 and Figure 8. Loosely install vertical adjusting screw (1) and washer (2) previously saved.
2. Loosely install mounting block (9) and billet headlamp (4) using horizontal adjusting screw (5), washers (6), lockwasher (7), and acorn nut (8).
3. Check headlamp for proper height and lateral alignment. Refer to Headlamp Alignment section in Instruction Sheet.

Connect Headlamp Wiring

Models With 4-Place Amp Multilock Connector:

1. Locate main harness pin housing.
2. Insert socket housing of billet headlamp into pin housing of main harness.

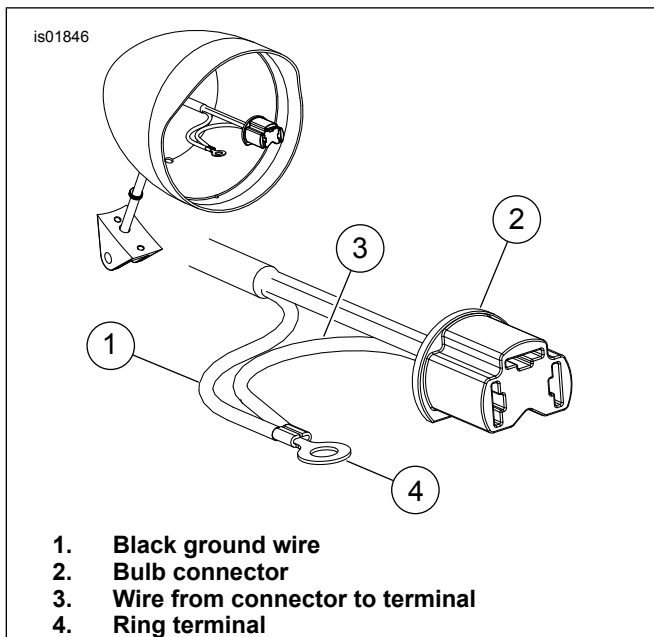

Figure 9. Clip Black Ground Wire

Models Without 4-Place Amp Multilock Connector:

Older chassis ground models, complete steps 1 and 2.

1. See Figure 9. Clip black ground wire (1) inside new billet headlamp close to the bulb connector (2). Refer to REPLACE LAMP ASSEMBLY AND BULB for procedures to disassemble billet headlamp.

NOTE

There are two black wires exiting the bulb. Be careful not to clip the wire that is grounded to the internal housing with ring terminal.

2. Pull the long black wire out of the sleeving and discard.
3. See Figure 10. Remove 1-1/2 inch (38.1 mm) of black jacket (1) at a convenient location from headlamp wire harness (2).
4. Using wire cutters, remove the headlamp socket housing (3).

NOTE

Use care not to cut the insulation on the three wires inside the headlamp wire harness.

5. Butt splice wires of billet headlamp to wires of main harness. Also refer to SEALED BUTT SPLICE CONNECTORS in Service Manual.
6. Strip 3/8-inch (9.5 mm) of insulation off the ends of the headlamp wires.
7. See Figure 11. Insert headlamp wires into butt splice connector until the stripped ends are housed inside the metal insert (1).
8. Crimp the wires (2) within the connector using suitable crimping tool.

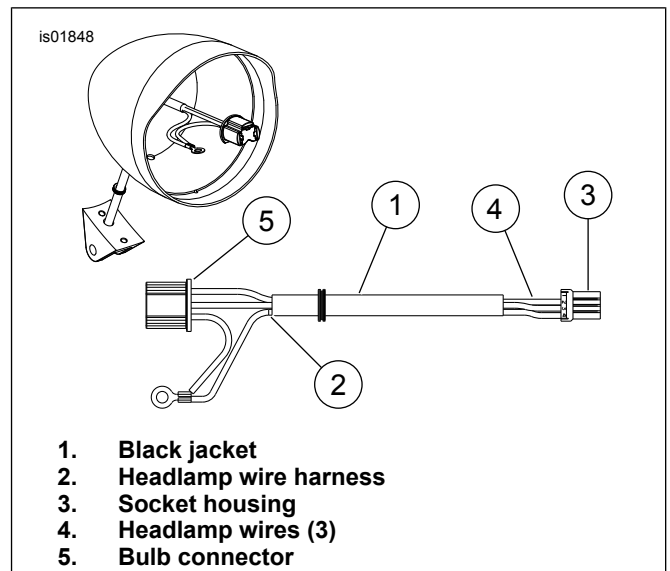

Figure 10. Remove Black Jacket, Socket Housing, and Strip Wires

⚠ WARNING

Be sure to follow manufacturer's instructions when using the UltraTorch UT-100 or any other radiant heating device. Failure to follow manufacturer's instructions can cause a fire, which could result in death or serious injury. (00335a)

9. Repeat steps on other side of butt splice connector for main harness wires.

NOTE

Stagger the splices so that the butt splice connectors are spaced at different positions along the length of the wires.

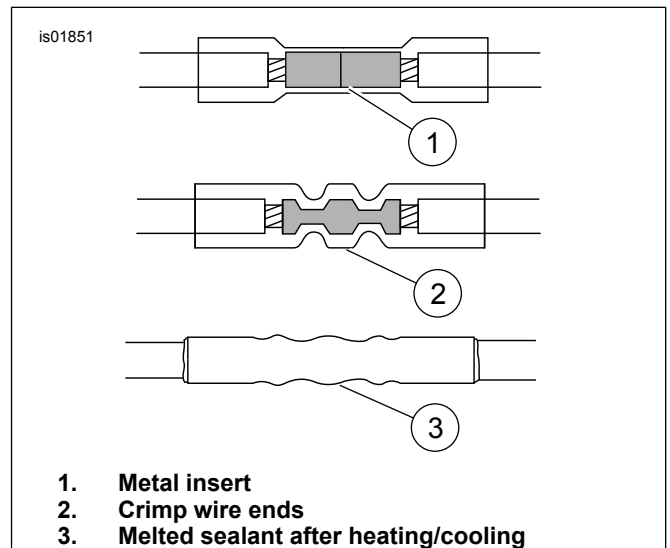

Figure 11. Install Sealed Butt Splice Connectors

- Avoid directing heat toward any fuel system component. Extreme heat can cause fuel ignition/explosion resulting in death or serious injury.
- Avoid directing heat toward any electrical system component other than the connectors on which heat shrink work is being performed.

- Always keep hands away from tool tip area and heat shrink attachment.
- Using the UltraTorch UT-100 (39969) or other suitable radiant heating device, heat the crimped splice to encapsulate the butt splice connection. Apply heat from the center of the crimp out to each end until the meltable sealant exudes out both ends of the connector.
 - Heat the center of the butt splice (3) until the crimp indentations disappear and the tubing assumes a smooth cylindrical appearance.
 - Slide section of black jacket previously removed over butt spliced wires and secure with clips.

Headlamp Alignment

⚠ WARNING

The automatic-on headlamp feature provides increased visibility of the rider to other motorists. Be sure headlamp is on at all times. Poor visibility of rider to other motorists can result in death or serious injury. (00030b)

- Verify correct front and rear tire pressure. Refer to TIRES AND WHEELS in Service Manual.
- Place motorcycle on level floor (or pavement) in an area with minimum light.
- Position motorcycle 25 ft (7.6 m) away from a screen or wall. Measure the distance from directly below the front axle to the base of the screen/wall.
- See Figure 12, Letter (A). Draw a horizontal line 35 inches (0.9 m) above floor on screen wall.

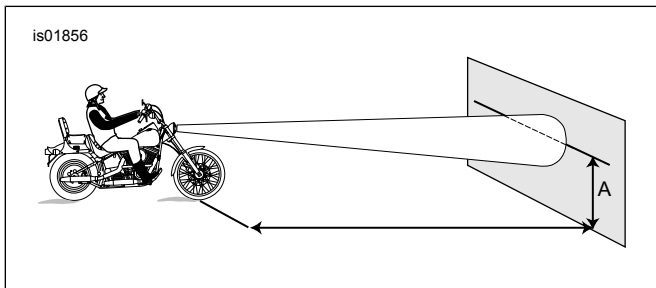

Figure 12. Headlamp Alignment

- Load vehicle with rider, passenger (if normally present) and any cargo. Weight will compress vehicle suspension slightly.
- Stand motorcycle upright with both tires resting on floor, and with front wheel held in straight alignment (directly forward).
- Sotail and Dyna Models:* Turn ignition switch to ON position. *Sportster Models:* Turn ignition/light switch to IGNITION position. *FXR Models:* Turn ignition/light switch to IGNITION position.
- See Figure 13. Set handlebar headlamp switch to high beam position.

- Check light beam for alignment as follows:
 - The main beam, which is a broad, flat pattern of light, should be centered equally above and below the horizontal line.
 - The main beam of light should also be directed straight ahead. Properly adjusted headlamps project an equal area of light to right and left of center.
- Tighten vertical adjusting screw and horizontal adjusting nut to 25-30 ft-lbs (33.9-40.7 Nm).

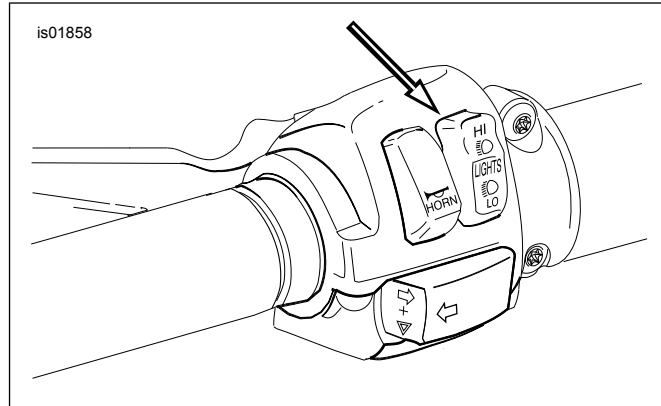

Figure 13. High Beam Setting

Final Assembly

Softail and FXR Models

- Install fuel tank. Refer to FUEL TANK in Service Manual.
- Connect negative (-) battery cable.

Dyna Models

- Install fuel tank. Refer to FUEL TANK in Service Manual.
- Install seat following the instructions in the Service Manual.
- Connect negative (-) battery cable.

FXR Models

- Install fuel tank. Refer to FUEL TANK in Service Manual.
- 2003-Earlier models:* Connect negative (-) battery cable.
- 2004-Later models:* Install maxi-fuse. Refer to MAXI-FUSE in Service Manual.

REPLACE LENS ASSEMBLY AND BULB

NOTICE

When replacement is required, use only the specified sealed beam unit or bulb, available from a Harley-Davidson dealer. An improper wattage sealed beam or bulb, can cause charging system problems. (00209a)

NOTICE

Never touch the quartz bulb. Fingerprints will etch the glass and decrease bulb life. Handle the bulb with paper or a clean, dry cloth. Failure to do so could result in bulb damage. (00210b)

▲ WARNING

Handle bulb carefully and wear eye protection. Bulb contains gas under pressure, which, if not handled carefully, could cause serious eye injury. (00062b)

NOTE

You do not need to remove billet headlamp from motorcycle to replace lamp assembly and bulb.

Disassembly

1. All models (except 2004-Later Sportster): Disconnect negative (-) battery cable. 2004-Later Sportster models: Remove maxi-fuse. Refer to MAXI-FUSE in Service Manual.
2. Using a 50/50 isopropyl alcohol/water solution, thoroughly clean the billet headlamp and surface of the chrome trim ring. Let dry completely.
3. See Figure 14. Using 1/16-inch allen wrench, remove outer set screw at bottom of headlamp shell.



Figure 14. Allen Wrench and Outer Set Screw

4. See Figure 15. Cut three 1/4 x 1-inch strips of two-sided tape and place at equal distance around the chrome trim ring.

NOTE

You can also use latex gloves to remove/install the chrome trim ring. This will enable you to grip the chrome trim ring and will not mark the finish.

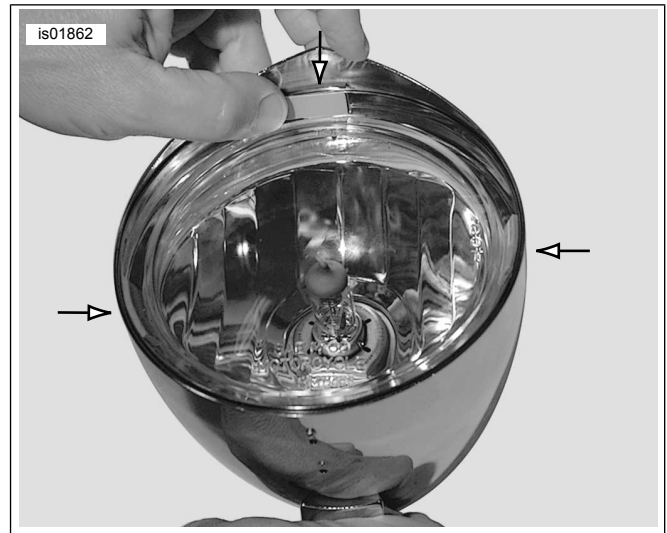

Figure 15. Place Two-Sided Tape on Chrome Trim Ring



Figure 16. Chrome Trim Ring (two-sided tape shown)

5. See Figure 16. Place fingers on two-sided tape and remove chrome trim ring (rotate counterclockwise) and O-ring.
6. See Figure 17. Using service tool, remove inner ring (rotate counterclockwise) and rubber O-ring.
7. See Figure 18. Unplug lamp assembly (1) from bulb connector (2) and remove from shell.



Figure 17. Service Tool and Inner Ring

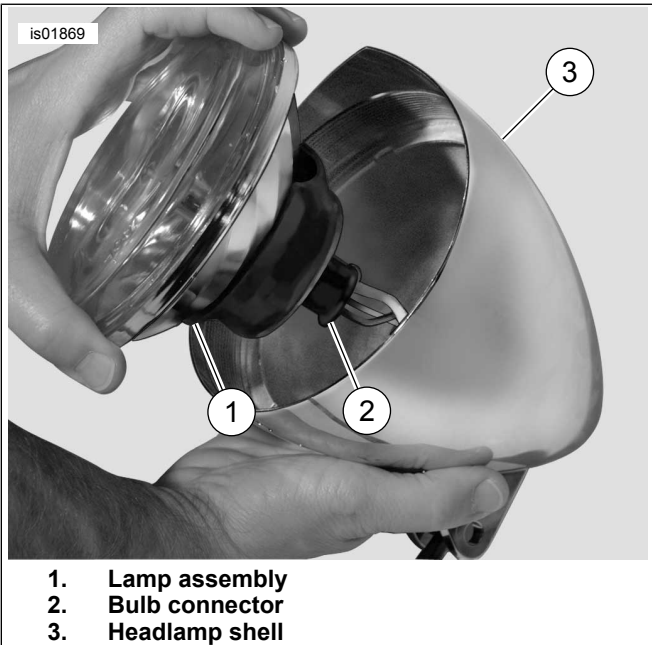

Figure 18. Lamp Assembly and Bulb Connector

8. See Figure 19. Remove rubber boot (1) from back of lens assembly and bulb (2).
9. Press ends of retaining clip (3) to unhook from notched retaining post, then pivot retaining clip back.
10. See Figure 20. Remove bulb (1) from lens assembly (2).

Assembly

1. See Figure 20. Fit replacement bulb (1) into lens assembly (2).
2. See Figure 19. Pivot the retaining clip (3) over the bulb and press the ends into the retaining post.

3. Install rubber boot (1) into back of lens assembly (2).
4. See Figure 18. Plug lamp assembly (1) into wire harness connector (2). Gently press lamp assembly into position inside headlamp shell.
5. See Figure 17. Using service tool, install inner ring (rotate clockwise) and rubber O-ring. Use care when installing ring to ensure proper threading into headlamp shell.
6. See Figure 16. Install chrome trim ring (rotate clockwise) and rubber O-ring. Remove strips of two-sided tape from ring if used. Use care when installing ring to ensure proper threading into headlamp shell.
7. See Figure 14. Using 1/16-inch allen wrench, install outer set screw at bottom of headlamp shell.

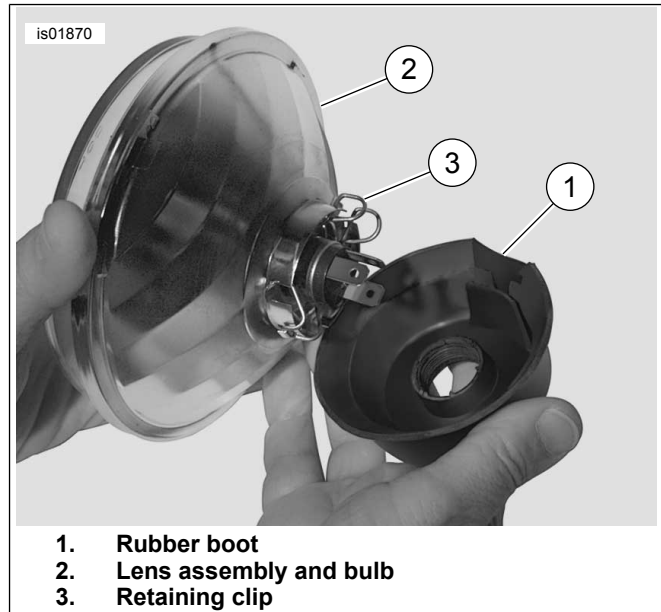

Figure 19. Lens Assembly, Retaining Clip, and Rubber Boot

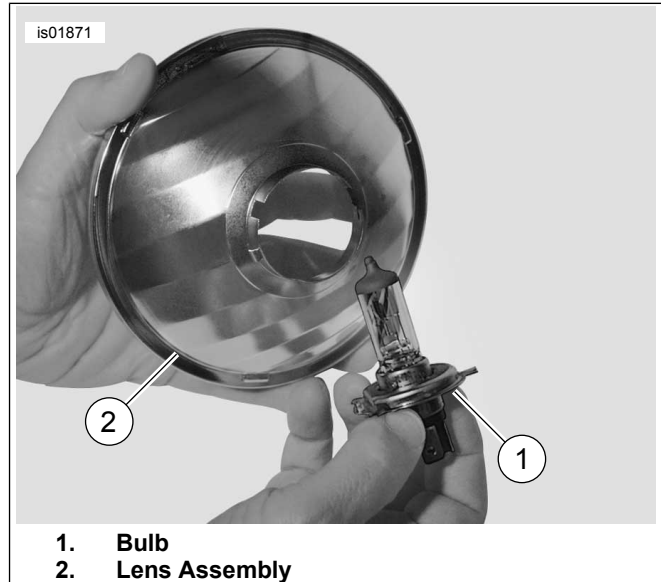

Figure 20. Lens Assembly and Bulb

SERVICE PARTS

is01908

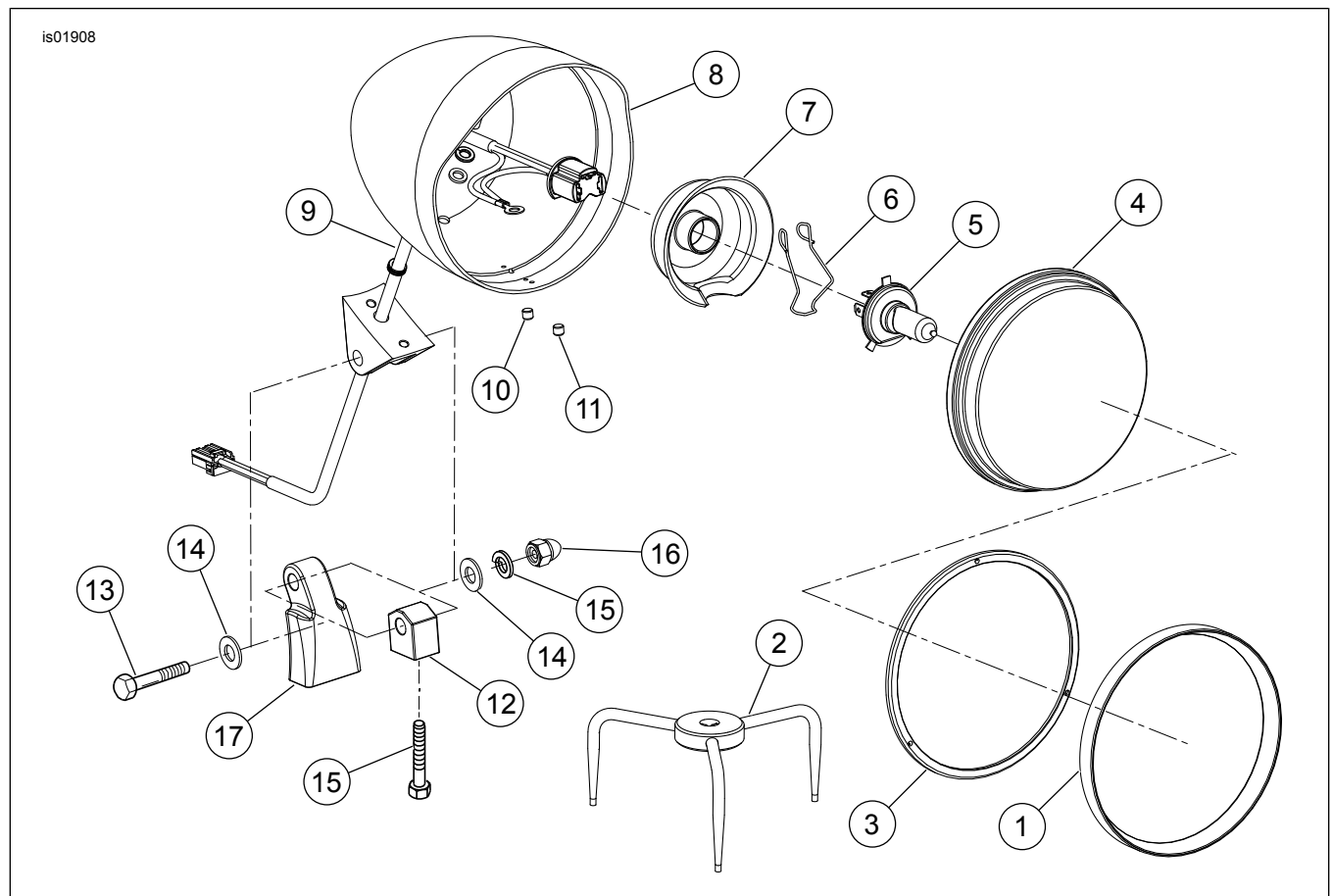

Figure 21. Service Parts: 5-3/4 Inch Billet Headlamp With Short/Tall Mounts

Table 2. Service Parts: 5-3/4 Inch Billet Headlamp With Short/Tall Mounts

Kit	Item	Description (Quantity)	Part Number
5-3/4 Inch Billet Headlamp 68593-06	1	Chrome trim ring	Not Sold Separately
	2	Service tool, inner ring	94950-06
	3	Inner ring	Not Sold Separately
	4	Lens Assembly	69668-06
	5	Bulb, dual filament 12V 60/55W H4	68329-03
	6	Retaining clip	Not Sold Separately
	7	Rubber boot	Not Sold Separately
	8	Headlamp shell, chrome	Not Sold Separately
	9	Headlamp wiring	Not Sold Separately
Short Mount Kit 68595-06	10	Set screw, #6-32 x 1/8 in. (outer trim ring)	Not Sold Separately
	11	Set screw, #6-32 x 3/16 in. (nesting ring)	Not Sold Separately
	12	Billet headlamp mount, short	Not Sold Separately
	13	Capscrew, hex hd 3/8-16 x 1-3/4 in. (2) (chrome); FXSTD models use quantity of one.	94237-91T
Tall Mount Kit 69611-06	14	Washer, flat 3/8 in (2) (chrome)	94067-90T
	15	Washer, lock 3/8 in (chrome)	94082-90T
	16	Nut, acorn 3/8-16 (chrome)	94008-90T
	17	Billet headlamp mount, tall	Not Sold Separately
Note: This kit also includes item 13 (quantity of one) and items 14 through 16.			

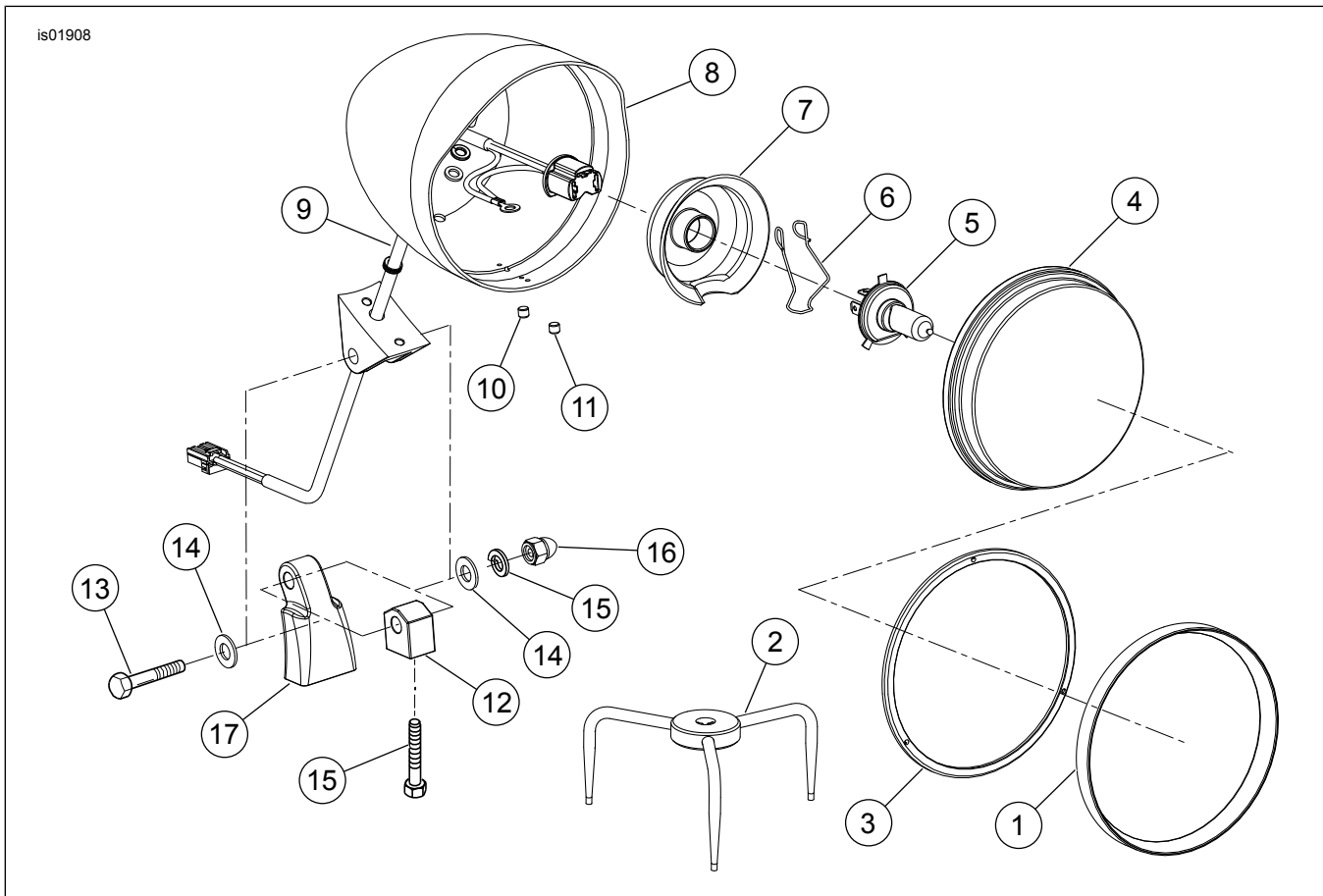

Figure 22. Service Parts: 4-1/2 Inch Billet Headlamp With Short/Tall Mounts

Table 3. Service Parts: 4-1/2 Inch Billet Headlamp With Short/Tall Mounts

Kit	Item	Description (Quantity)	Part Number
4-1/2 Inch Billet Headlamp 69851-06	1	Chrome trim ring	Not Sold Separately
	2	Service tool, inner ring	69852-06
	3	Inner ring	Not Sold Separately
	4	Lens Assembly	69856-06
	5	Bulb, dual filament 12V 60/55W H4	68329-03
	6	Retaining clip	Not Sold Separately
	7	Rubber boot	Not Sold Separately
	8	Headlamp shell, chrome	Not Sold Separately
	9	Headlamp wiring	Not Sold Separately
	10	Set screw, #6-32 x 1/8 in. (outer trim ring)	Not Sold Separately
	11	Set screw, #6-32 x 3/16 in. (nesting ring)	Not Sold Separately
Short Mount Kit 68595-06	12	Billet headlamp mount, short	Not Sold Separately
	13	Capscrew, hex hd 3/8-16 x 1-3/4 in. (2) (chrome); FXSTD models use quantity of one.	94237-91T
	14	Washer, flat 3/8 in (2) (chrome)	94067-90T
	15	Washer, lock 3/8 in (chrome)	94082-90T
Tall Mount Kit 69611-06	16	Nut, acorn 3/8-16 (chrome)	94008-90T
	17	Billet headlamp mount, tall	Not Sold Separately
Note: This kit also includes item 13 (quantity of one) and items 14 through 16.			