



INSTRUCTIONS

J03369

2012-10-22



XL 2-UP CUSTOM SEAT KITS

GENERAL

Kit Number

See Table 1 and Table 2.

Models

For model fitment information, see the P&A Retail Catalog or the Parts and Accessories section of www.harley-davidson.com (English only).

▲ WARNING

Do not install these seat kits on motorcycles that are not equipped with an appropriate grab strap and passenger footpegs. If footpegs and grab strap are not installed, passenger could fall from moving motorcycle or grab onto operator, causing loss of control and death or serious injury. (00410b)

Additional Parts Required

- XL883 and XL883L models require the separate purchase of Passenger Footpeg Kit 50203-04, which is available from a Harley-Davidson dealer.
- XL1200N, XL883N and XL1200X models require separate purchase of guide washer 7487.

Kit Contents

See Table 1 and Table 2 for the kit number and corresponding grabstrap number.

See Figure 7 and Table 3 for a list of the service parts.

Table 1. Kit Contents-4.5 Gallon Tank

Kit Number	Grabstrap	Kit Number	Grabstrap
51686-05	51295-04	52907-04A	51312-07
52859-04B	51312-07	52923-04B	51312-07
52883-04A	51312-07	52000120	51312-07

Table 2. Kit Contents-2.1 and 3.3 Gallon Tank

Kit Number	Grabstrap	Kit Number	Grabstrap
51386-04	51295-04	52849-04B	51312-07
51684-05	51295-04	52871-04A	51312-07
51685-05	51295-04	52884-04A	51312-07
52176-06	51295-04	52916-04B	51312-07
52184-06	51295-04	52000121	51312-07

INSTALLATION

NOTE

When installing this kit, be careful not to scratch painted surfaces (fender, tank, etc.) with the metal tabs on the seat.

Models Originally Equipped With Solo Seat

1. Remove the seat according to the instructions in the owner's manual.
2. See Figure 1. Remove and discard seat post washer (2) and screw (3) from the front fender hole.
3. **For XL883 and XL883L models:** See Figure 2. Remove plastic cap (1) from rearward fender hole and save.
4. Remove retention nut (2) and washer (3) from middle fender hole.

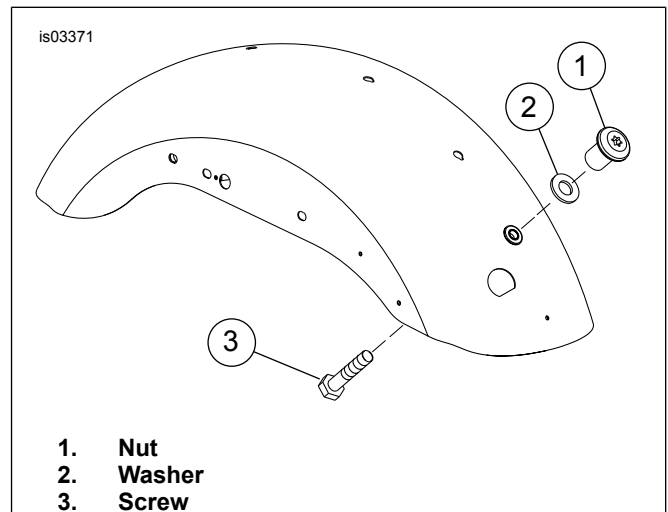

Figure 1. Front Fender Hole Hardware (2006 Fender Shown)

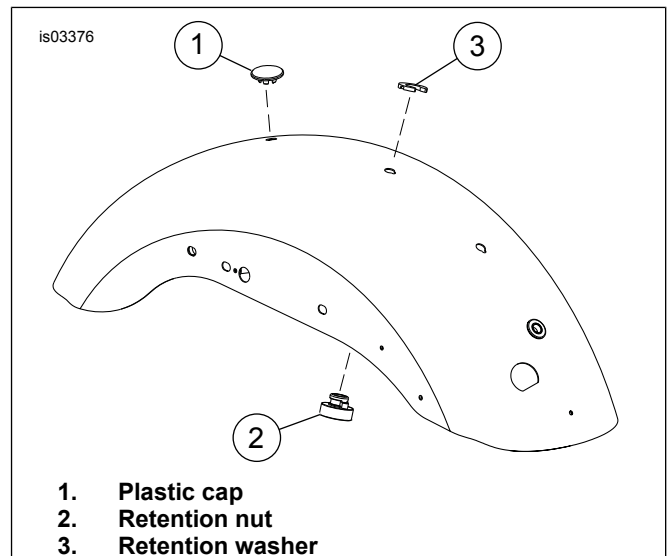

Figure 2. Retention Nut and Plastic Cap (Solo Seats)

5. See Figure 3. Install retention nut (1) and washer (2) into rearward fender hole.
 - a. See Figure 4. Place retention nut (1) over cable strap (2) so wide end of nut rests on eye of cable strap.
 - b. Thread cable strap up under fender and through fender hole.
 - c. Pull up on cable strap to hold nut snug against underside of fender.
 - d. With rib on retention nut seated into notch in fender hole, slide retention washer (3) into place from rear. This will lock retention nut in place.
6. See Figure 3. Install plastic cap in middle fender hole.
7. **For XL1200N, XL883N, and XL1200X:** Remove screw in rearward fender hole and discard.

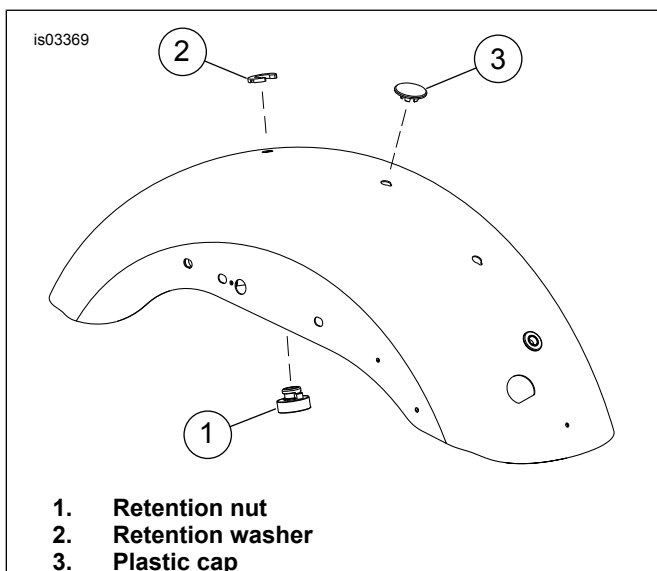

Figure 3. Retention Nut and Plastic Cap (2-Up Seats)

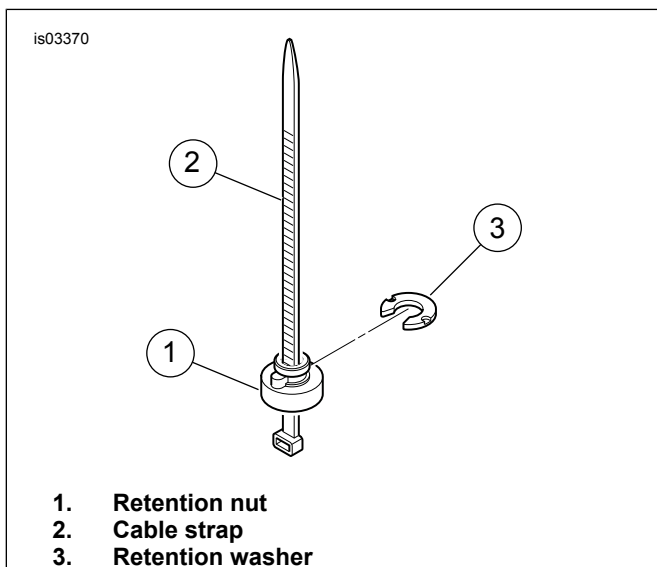

Figure 4. Retention Nut Installation

Models Originally Equipped With 2-Up Seat

1. Remove the seat according to the instructions in the Owner's Manual.
2. See Figure 1. Remove and discard nut (1), washer (2), and screw (3) from the front fender hole.

Install Grabstrap

1. See Figure 7. Insert screw (1) through front fender hole from inside the fender.
2. See Figure 5. *2007-2009 models:* Route grabstrap under ECM wire harness (1) and antenna wire (2). It is important to route grabstrap **under** wire harness and antenna wire so it does not interfere with wiring. If grabstrap is routed over wires, contact may occur when seat is fully installed. *All other models:* Loop grabstrap around top of rear fender.

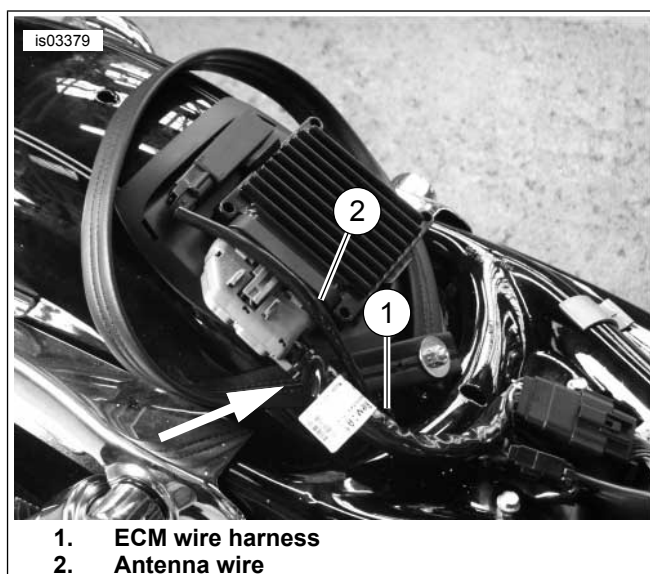

Figure 5. Grabstrap Routing Under Wires (2007-2009)

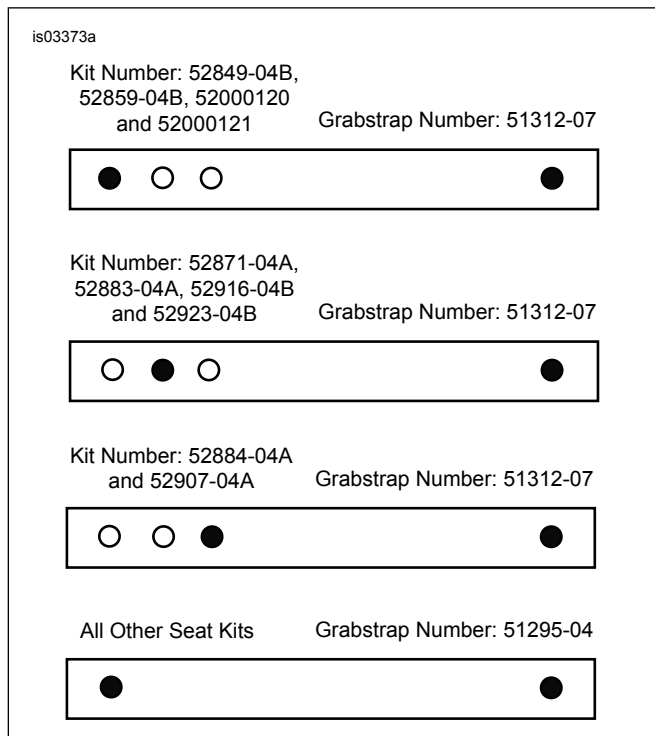

Figure 6. Grabstrap Installation

3. See Figure 6. Assemble grabstrap (Figure 7, Item 2) onto screw using appropriate holes for the seat kit being installed.
4. See Figure 7. Install washer (3) and hex nut (4) onto screw (1). Tighten to 36-60 **in-lbs** (4.1-6.8 Nm).

Install Custom 2-Up Seat

1. See Figure 7. Slip rear section of seat (5) through grabstrap (2).

2. Bring seat forward and engage the tongue on bottom front of seat into the slot at base of fuel tank.

NOTE

For XL 1200N, XL883N and XL1200X models, place guide washer over rear seat mounting hole in fender before installing seat knob.

3. Secure seat to fender (A) using knurled knob (6) and Neoprene washer (7) from kit.
 - a. Install washer onto knob.
 - b. Push down and hold seat in position while tightening knob securely to fender nut.
4. Remove adhesive backing from Bar& Shield emblem (8) and install it in recess of knob face.

NOTE

The seat can be adjusted to eliminate the gap between the front of the seat and the rear of the fuel tank console.

▲ WARNING

After installing seat, pull upward on seat to be sure it is locked in position. While riding, a loose seat can shift causing loss of control, which could result in death or serious injury. (00070b)

5. To adjust the seat, turn the seat over and loosen the two button head screws that secure the rear tab bracket (11). Slide the bracket forward or back as required. Tighten the button head screws to 10.8 N·m (96 **in-lbs**).

SERVICE PARTS

is03374b

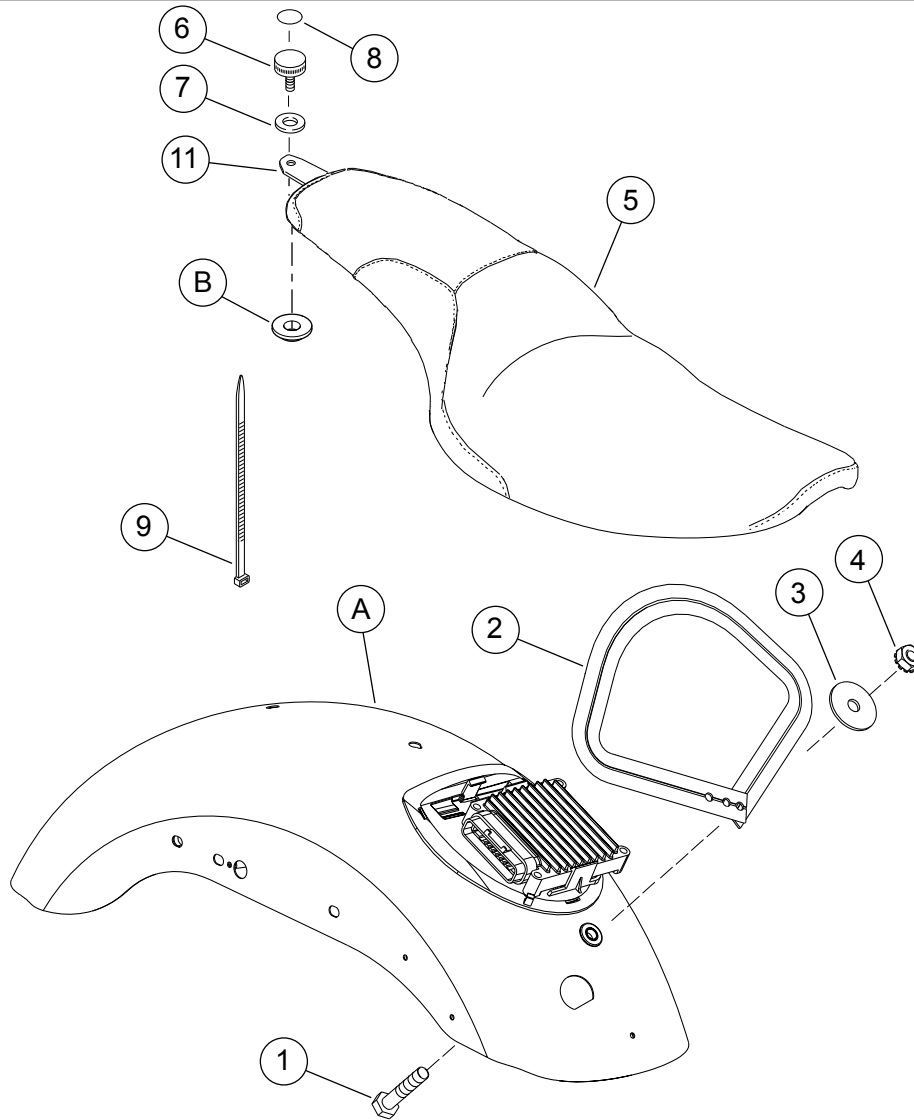

Figure 7. Service Parts: XL 2-Up Custom Seat Kits

Table 3. Service Parts: XL 2-Up Custom Seat Kits

Item	Description (Quantity)	Part Number	Item	Description (Quantity)	Part Number
1	Screw, hex 1/4-20 X 1-1/4 in.	3993	7	Washer, Neoprene	6205
2	Grabstrap	See Table 1 and 2	8	Emblem, Bar & Shield	14628-96
3	Washer, plain	6036	9	Strap, cable	10039
4	Nut, keps hex 1/4-20	7792	10	Leather dressing (Not Shown)	Not Sold Separately
5	Seat	Not Sold Separately	11	Rear tab bracket kit (includes two button head mounting screws, not shown)	51699-09
6	Knob, knurled 1/4-20	3649	Items mentioned in text, but not included in kit:		
			A	Rear fender (2007 model shown)	
			B	Guide Washer (XL1200N, XL883N and XL1200X models only)	7487