



INSTRUCTIONS

J04477

2016-08-22



PASSENGER FOOTPEG SUPPORT KIT

GENERAL

Kit Number

50932-08

Models

For model fitment information, see the P&A retail catalog or the Parts and Accessories section of www.harley-davidson.com (English only).

Installation Requirements

Separate purchase of footpegs is required for proper installation of this kit on your model motorcycle. See the P&A retail catalog or the Parts and Accessories section of www.harley-davidson.com (English only) for a selection of available footpegs.

⚠ WARNING

Rider and passenger safety depend upon the correct installation of this kit. Use the appropriate service manual procedures. If the procedure is not within your capabilities or you do not have the correct tools, have a Harley-Davidson dealer perform the installation. Improper installation of this kit could result in death or serious injury. (00333b)

Kit Contents

See Figure 1. and Table 1.

INSTALLATION

⚠ WARNING

Footrests must fold up and toward rear of motorcycle if struck. Failure to set footrests to fold up and back could result in death or serious injury. (00366a)

1. See Figure 1. Install footpeg support bracket (7) to the left side of the frame using screw (1). Tighten to 47.4–61 N·m (35–45 ft-lbs).
2. Install the footpeg support (6) to the bracket with screw (2). Align the support to angle 10 to 15 degrees from vertical to the rear of the frame. Tighten to 47.4–61 N·m (35–45 ft-lbs).
3. Install the footpeg (A) to the support with the spring washer (5), (flat side facing the support). Insert the clevis pin through the support and footpeg. Fasten the retaining ring to the pin.
4. Repeat Steps 2 and 3 for right side footpeg installation to the muffler support bracket, as shown in Figure 1.

SERVICE PARTS

1003716

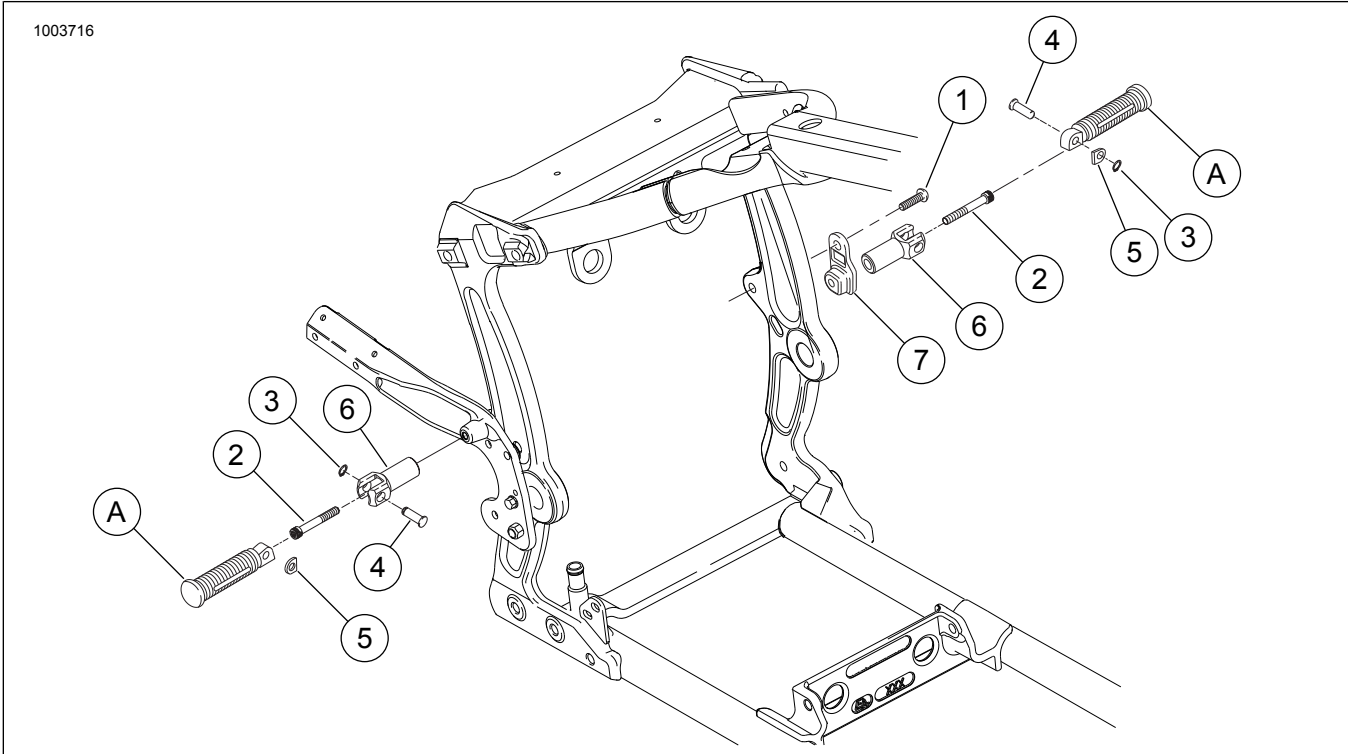

Figure 1. Service Parts, Passenger Footpeg Support Kit

Table 1. Service Parts

| Item | Description (Quantity) | Part Number |
|--|-------------------------------------|-------------|
| 1 | Button head screw, TORX® T50 | 4390 |
| 2 | Socket head cap screw, TORX T45 (2) | 4454 |
| 3 | Retaining ring (2) | 11304 |
| 4 | Clevis pin (2) | 45041-01A |
| 5 | Spring washer (2) | 50912-72 |
| 6 | Footpeg support (2) | 50943-05A |
| 7 | Support bracket | 50944-05 |
| Items mentioned in text, but not included in kit: | | |
| A | Footpeg | |