



INSTRUCTIONS

J03938

2007-08-10



FLSTF SOFTAIL SADDLEBAG KIT

GENERAL

Kit Number

90715-07XX

Models

For model fitment information, please see the P&A Retail Catalog or the Parts and Accessories section of www.harley-davidson.com (English only).

Additional Parts Required

Proper installation of this kit requires the separate purchase of the following items which are available from a Harley-Davidson dealer.

- Loctite[®] 243 Threadlocker and Sealant - Blue (99642-97)
- Terminal Pick Tool (HD-41475-100)

Models equipped with detachable sissy bar or luggage rack require the additional purchase of Softail Hard Saddlebag Hardware Kit (53075-03).

⚠ WARNING

Rider and passenger safety depend upon the correct installation of this kit. Use the appropriate service manual procedures. If the procedure is not within your capabilities or you do not have the correct tools, have a Harley-Davidson dealer perform the installation. Improper installation of this kit could result in death or serious injury. (00333b)

NOTE

This instruction sheet references Service Manual information. A Service Manual for your model motorcycle is required for this installation and is available from a Harley-Davidson dealer.

Kit Contents

This saddlebag kit includes the following kits and assemblies:

Table 1. Kit Contents

Kit/Assembly	See Figure/Table:
Saddlebag Bracket Kit (90715-07)	Figure 18, Table 3
Saddlebag Bracket Hardware Kit (88208-07)	Figure 18, Table 3
Turn Signal Wiring Kit (72509-00)	Figure 19, Table 4
Saddlebag Assembly, L.H. (90026-07XX)	Figure 20, Table 5
Saddlebag Assembly, R.H. (90027-07XX)	Figure 20, Table 5

⚠ WARNING

Do not exceed saddlebag weight capacity. Put equal weight in each bag. Too much weight in saddlebags can cause loss of control, which could result in death or serious injury. (00383a)

NOTE

Maximum weight capacity is 7 lbs (3.18 Kg) in each saddlebag.

PREPARE FOR SERVICE

1. Remove seat according to the instructions in the Service Manual.

⚠ WARNING

To prevent accidental vehicle start-up, which could cause death or serious injury, disconnect battery cables (negative (-) cable first) before proceeding. (00307a)

⚠ WARNING

Disconnect negative (-) battery cable first. If positive (+) cable should contact ground with negative (-) cable connected, the resulting sparks can cause a battery explosion, which could result in death or serious injury. (00049a)

2. Disconnect battery cables, negative (-) cable first.

REMOVAL

Remove Turn Signals

1. Locate and separate tail lamp connector (8-place multilock) under seat. Then remove wires from connector. Refer to AMP MULTILOCK ELECTRICAL CONNECTORS in Service Manual.
2. See Figure 1. Remove two screws and tail lamp lens (1) from base (2).
3. See Figure 2. Using a Terminal Pick Tool (1), depress locking tabs and remove turn signal connectors (2-place) (2, 3). Save connectors for kit installation. Refer to AMP MULTILOCK ELECTRICAL CONNECTORS in Service Manual.
4. Remove wires from turn signal connectors. Take note of terminal location for proper reassembly.
5. See Figure 3. Remove turn signal wiring (1, 2) from clips (3) under rear of fender and pull wires out.



NOTE

When performing Steps 6 through 11, complete for one side before continuing to the opposite side. This will secure the fender during removal.

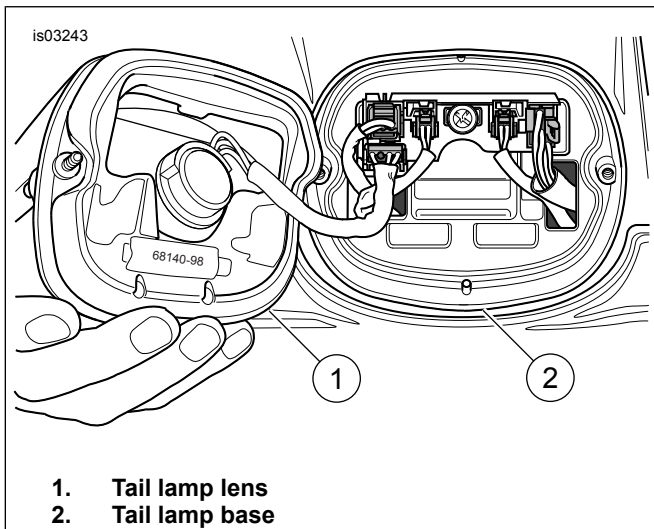

Figure 1. Remove Tail Lamp Lens

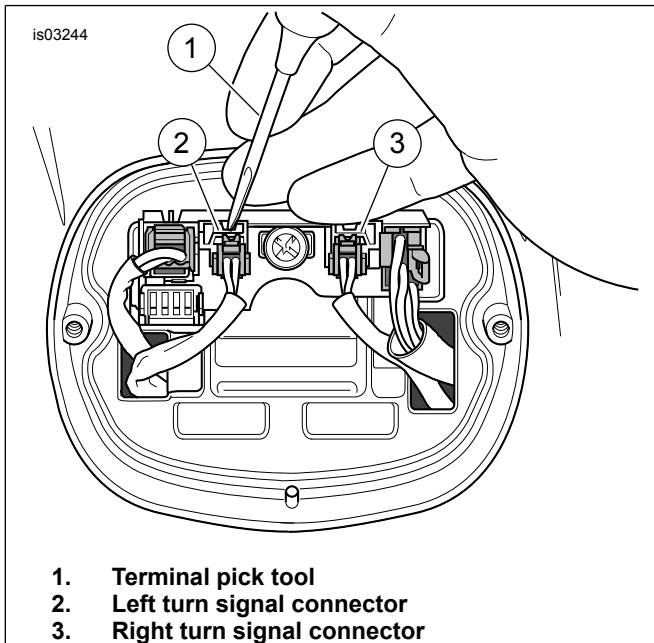

Figure 2. Remove Turn Signal Connectors

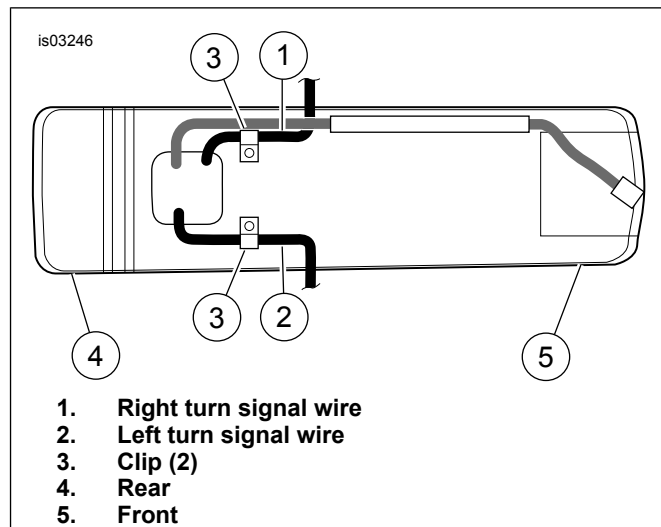

Figure 3. Turn Signal Wires and Clips (Viewed from Bottom Inside Rear Fender)

6. See Figure 4. Remove three rear screws (1) from fender support (2).
7. Loosen but do not remove two front screws (3) from fender support.
8. Gently pull turn signal wiring out through rear fender.
9. Remove turn signal mount hardware from fender support then remove turn signal from mount.
10. Carefully pull turn signal wiring out through turn signal mount. Discard mount.
11. Install fender support on rear fender using original screws and snug into place.

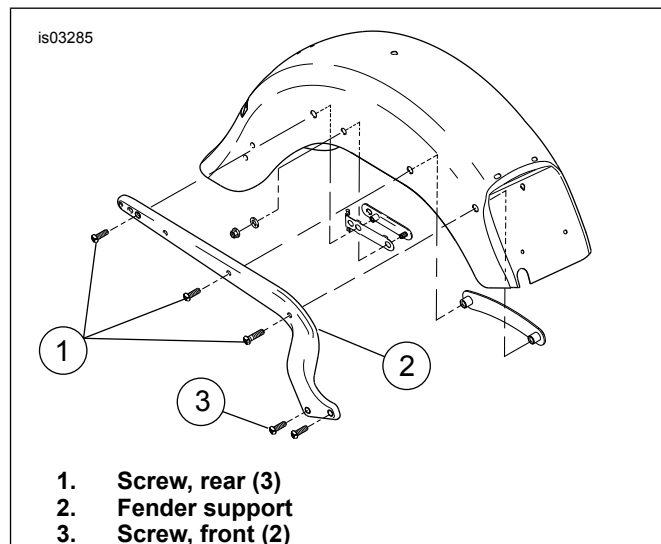

Figure 4. Fender Support Screws and Fender Support

Remove Passenger Footpeg and Debris Deflector

1. Remove belt guard/debris deflector to provide adequate access for installing saddlebag mounting hardware. Refer to BELT GUARD/DEBRIS DEFLECTOR REMOVAL in Service Manual.
2. See Figure 5. Remove passenger footpeg (1) from footpeg support (2) by removing pin (3), wave washer (4), and clip (5). Save parts for kit installation.
3. Remove bolt (6, 7) that runs through footpeg support to remove support. Discard bolt.

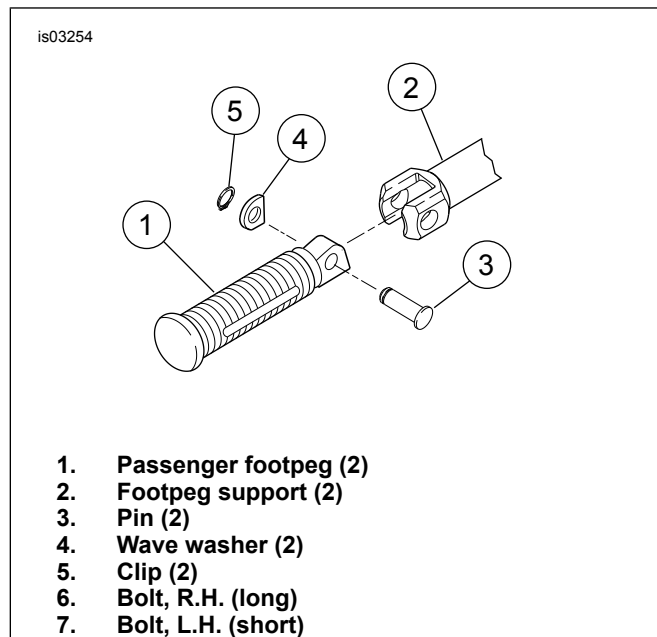

Figure 5. Passenger Footpeg Mounting (Right Side)

ASSEMBLY

NOTE

Proper installation of this kit requires that the tasks be completed for one side of the motorcycle first before continuing to the opposite side.

Assemble Relocation Bracket and Turn Signals

1. See Figure 6. Route lamp wiring through turn signal relocation bracket.

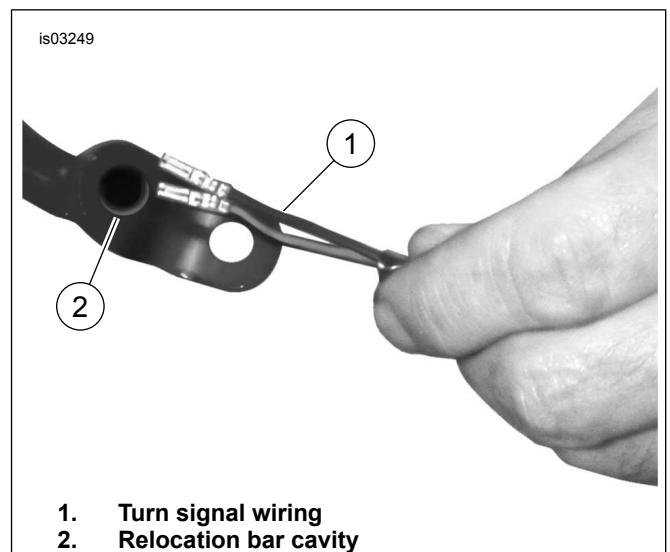

Figure 6. Route Turn Signal Wiring

2. For 3-Inch Signal Lamp:For 2-3/8 Inch Signal Lamp:

- a. See Figure 7. Apply Loctite 243 (blue) to threads of screw.
- b. Install turn signal to relocation bracket (1) using screw (2) and lockwasher (3). Tighten securely.
- c. See Figure 8. Apply Loctite 243 (blue) to threads of screw.
- d. Install turn signal to relocation bracket (1) using screw (2), lockwasher (3), and spacer (4). Spacer should be installed between lamp and relocation bracket.

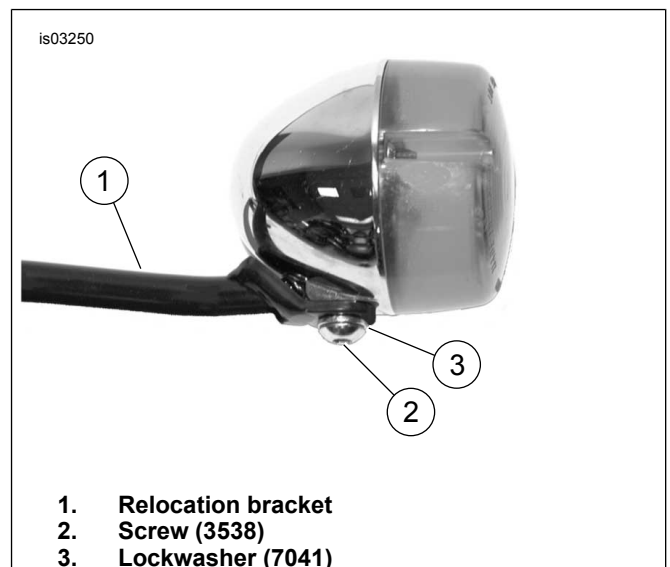

Figure 7. Install 3-Inch Turn Signals

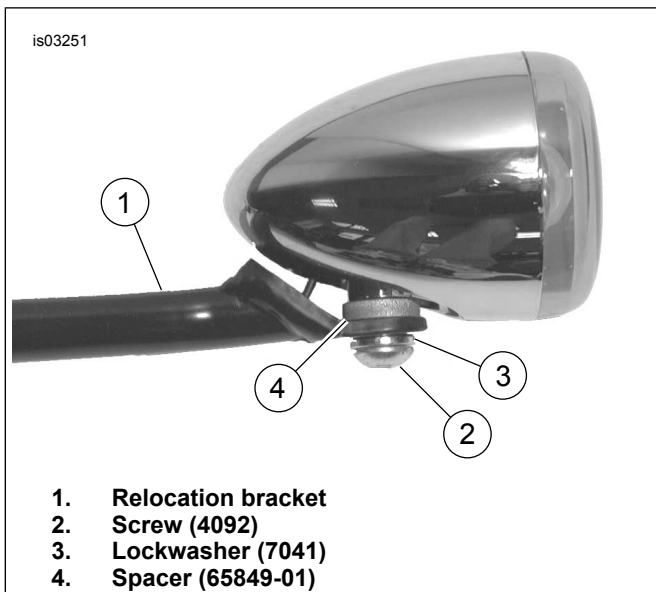

Figure 8. Install 2-3/8 Inch Turn Signals

SADDLEBAG BRACKET INSTALLATION

NOTE

Proper installation of this kit requires that the tasks be completed for one side of the motorcycle first before continuing to the opposite side.

Install Saddlebag Support Hanger and Turn Signal Relocation Bracket

1. See Figure 9. Install saddlebag support hanger (1) to fender support (2) and fender using two screws (3) and original stud plate.
2. Tighten screws to 27 ft-lbs (37 Nm).
3. If docking hardware is used, install docking points (4) between fender support and saddlebag support hanger.
4. Press chrome plug (5) from wiring kit into hole to cover original turn signal location.
5. Obtain turn signal and relocation bracket previously assembled.
6. See Figure 10. Install turn signal and relocation bracket (1) to saddlebag support hanger using two screws (2) and nuts (3).

Install Forward Support Bracket and Footpeg Support

Left Side:

1. See Figure 5. Align footpeg support (2) with hole in frame.
2. See Figure 18. Insert bolt (14) through footpeg support and frame. Threads should be exposed approximately 1/2 in. on inner side of frame.
3. Install forward support bracket (5) onto bolt (14).
4. Install shoulder washer (16) with shoulder oriented toward bracket, then install nut (17) onto bolt and finger tighten.

Right Side:

1. See Figure 5. Align footpeg support (2) with hole in muffler support.

2. See Figure 18. Insert bolt (15) through footpeg support (1) and muffler support. Threads should be exposed approximately 1/2 in. on inner side of frame.
3. Install forward support bracket (6) onto bolt (15).
4. Install shoulder washer (16) with shoulder oriented toward bracket, then install nut (17) onto bolt and finger tighten.

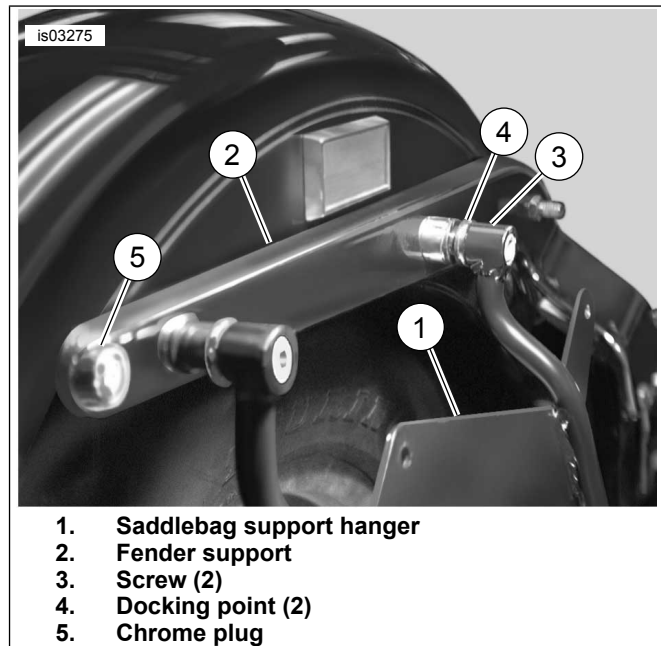

Figure 9. Install Saddlebag Support Hanger

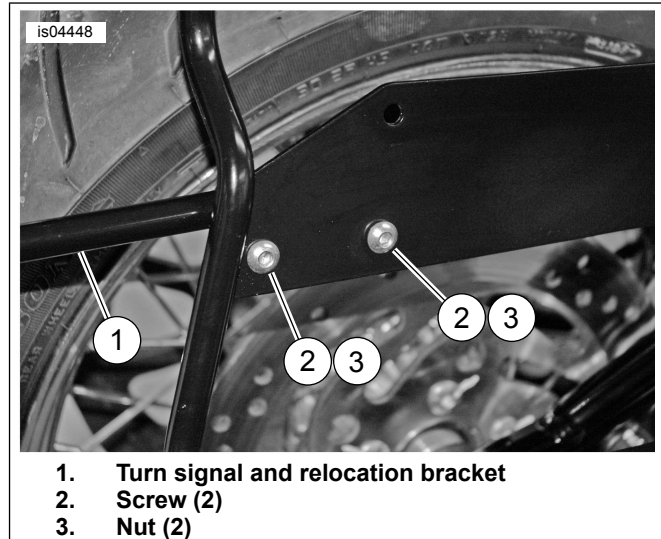

Figure 10. Install Turn Signal and Relocation Bracket

Install Forward Support Bracket to Saddlebag Support Hanger

NOTE

See Figure 11. If docking hardware is installed, use the inner two holes (1) to mount the forward support bracket (2) to the saddlebag support hanger (3). If docking hardware is not installed, use the outer two holes (4).

1. See Figure 18. Install two screws (8) through saddlebag support hangers (1, 2) and into forward support brackets (5, 6). Secure with nuts (9). Tighten nuts to 10 ft-lbs (13.1 Nm).

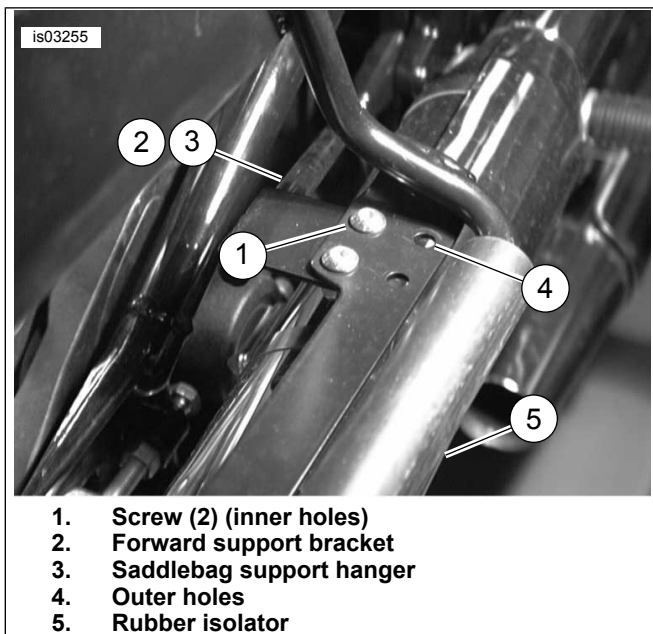

Figure 11. Install Forward Support Bracket to Saddlebag Support Hanger

2. Tighten nuts (17) on forward support brackets (5, 6) to 25-30 ft-lbs (34-41 Nm).
3. Install rubber isolator (18) over saddlebag support hangers (1, 2) with "flat" side facing down.

Install Passenger Footpeg and Debris Deflector

1. See Figure 5. Install passenger footpeg (1) to footpeg support (2) using original pin (3), wave washer (4), and clip (5).
2. Install debris deflector. Refer to BELT GUARD/DEBRIS DEFLECTOR REMOVAL in Service Manual.

ROUTE TURN SIGNAL WIRING

1. See Figure 19. Install terminals in turn signal connectors (2-place) at locations previously noted. Refer to AMP MULTILOCK ELECTRICAL CONNECTORS in Service Manual.
2. Connect socket half of turn signal connector to pin half on wire harness (2).
3. Remove adhesive backing from two clips (3) and install to support plate.
4. Route wiring from relocation bracket along support plate and bend clip tabs to capture wiring.
5. See Figure 12. Continue routing up the inside of saddlebag support hanger (1) and fasten turn signal wiring (2) to hanger using cable straps (3). Clip excess plastic from ends of straps.
6. Remove adhesive backing from two clips (4) and install to bottom of fender support (5).

7. Insert wiring into each clip and bend tabs to capture wiring.

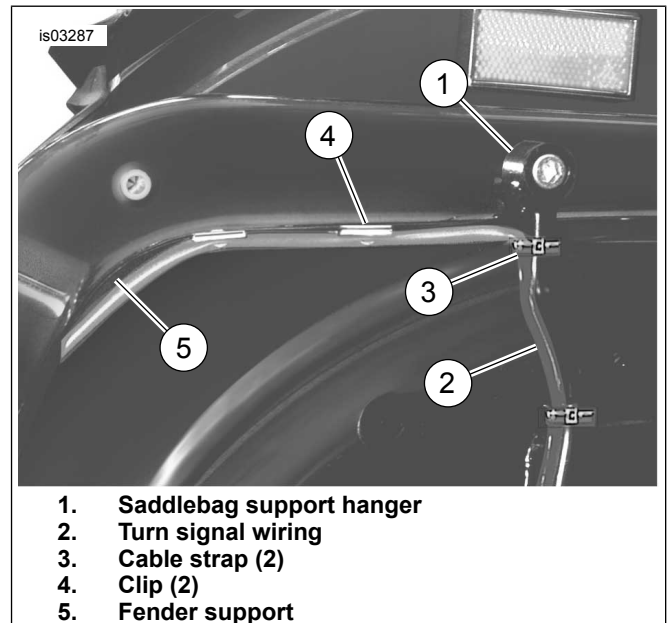

Figure 12. Route Wiring and Install Straps and Clips

8. Continue to route wiring under fender support and around front of fender to turn signal wire connector (right side of fender under seat).
9. Install signal wiring terminals to turn signal connector. Refer to AMP MULTILOCK ELECTRICAL CONNECTORS in Service Manual.
10. Complete the following steps if the power wire is too short to reach the turn signal connector connector after routing. Refer to SEALED BUTT SPLICE CONNECTORS INSTALLATION in Service Manual.
 - a. Measure and cut a section of wire from the wire harness (Figure 19, Item 2) provided in kit.
 - b. Cut terminal end off leaving approximately 3 inches of wire.
 - c. Using butt connectors (Figure 19, Item 5), splice jumper between original wire and terminal end.
11. See Figure 1. Install tail lamp lens (1) on base (2) using two screws.
12. Tighten screws to 20-24 in-lbs (2.3-2.7 Nm).

SADDLEBAG INSTALLATION

1. See Figure 13. Install rubber grommets (1) into holes inside of saddlebag.
2. Install spacer (2) into each of the grommets.
3. See Figure 14. Hold saddlebag (1) up to hanger (2) and locate spacer (3) between saddlebag and support hanger.

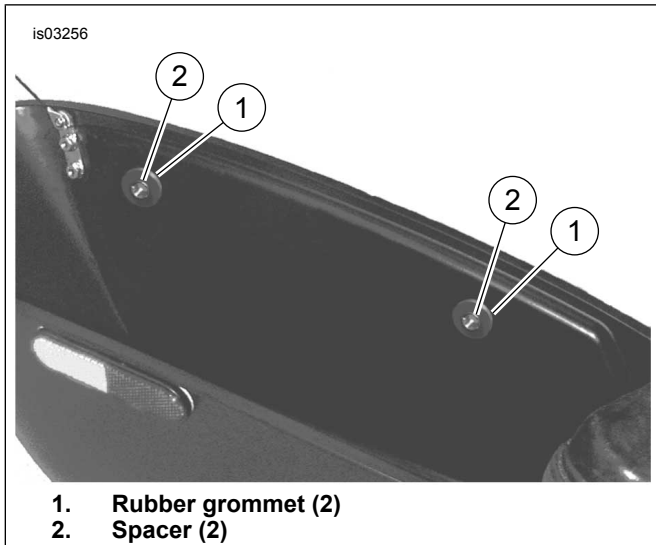

Figure 13. Install Grommets and Spacers

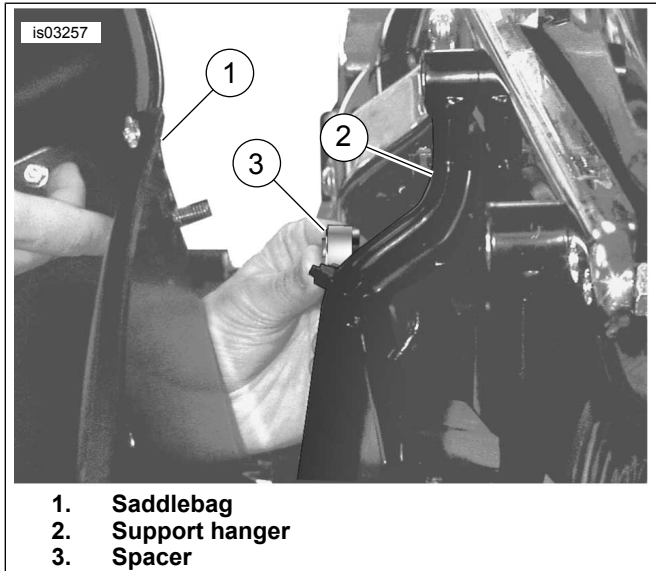

Figure 14. Install Spacer

4. See Figure 18. Install screw (22) and washer (23) from side saddlebag, through spacer (21). Then install nut (9), finger tight.
5. Install screw, washer, and spacer for remaining hole in saddlebag and hanger.
6. Make sure saddlebag is properly aligned and tighten screws and nuts securely.

RETURN TO SERVICE

Install Reflectors

NOTE

Red reflectors are included in this kit and must be installed to meet domestic and international requirements.

▲ WARNING

Federal Motor Vehicle Safety Standard (FMVSS) 108 requires motorcycles to be equipped with rear and side reflectors. Be sure rear and side reflectors are properly mounted. Poor visibility of rider to other motorists can result in death or serious injury. (00336b)

1. See Figure 15. Position reflector approximately 7 in. (179 mm) from saddlebag front and 1/4 in. (6 mm) from lip of saddlebag bottom.
2. Using a 50/50 isopropyl alcohol/water solution, thoroughly clean the surface where the reflector will be installed.
3. Allow the surface to dry completely before continuing.
4. Remove the adhesive backing and install reflector on saddlebag.
5. Let the adhesive cure for at least 24 hours at no less than 60°F (16°C).
6. Repeat steps for opposite side.

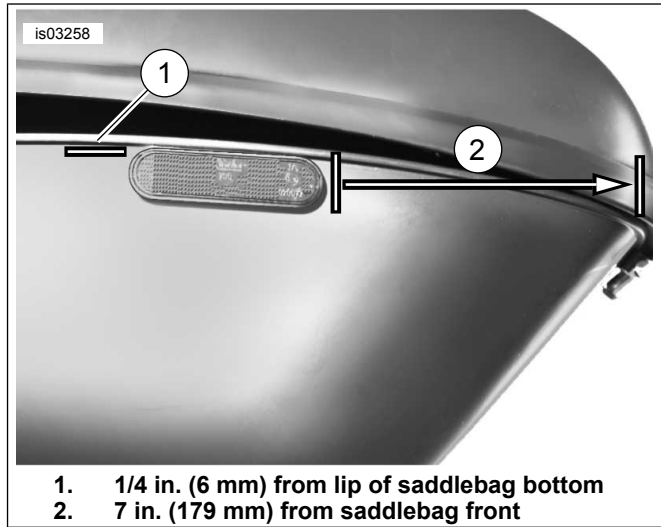

Figure 15. Install Reflector on Saddlebag

Hinge Replacement (Optional)

NOTE

Saddlebags are shipped with hinge and tether for raising and lowering lid. However, due to various styles of seat or accessories installed, it may be preferable to replace existing hinge with optional hinge provided in kit which allows complete removal of lid.

1. See Figure 16. Remove screws (1, 2) securing tether to saddlebag lid and base.
2. Remove tether (3) from saddlebag.
3. See Figure 17. Remove and save C-clip and pin (1) from hinge. Separate saddlebag lid from body.
4. Remove and save two screws (2) securing hinge to saddlebag lid.

- Slide hinge (3) out from under rubber seal.

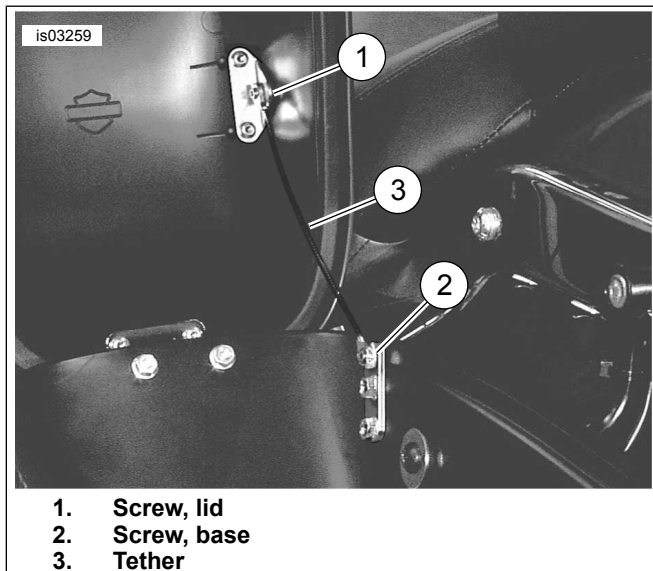

Figure 16. Remove Tether

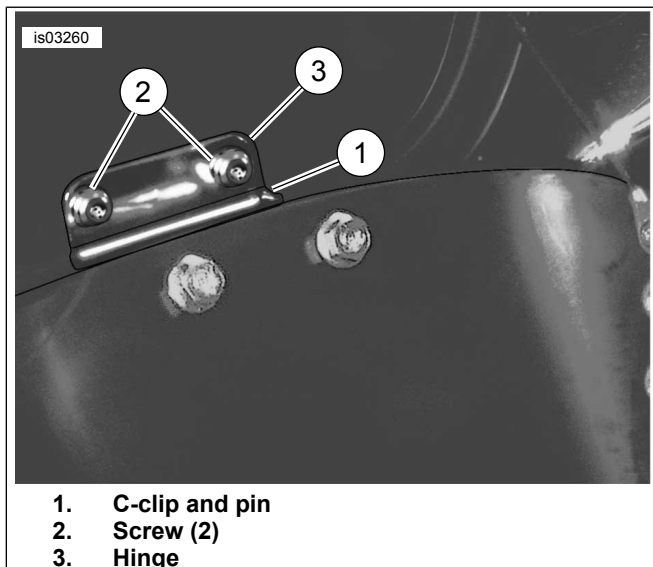

Figure 17. Remove Hinge

- See Figure 18. Slide hinge (25) under rubber seal and fasten hinge half to saddlebag lid using screws (Figure 17, Item 2) previously removed. Tighten screws securely.
- See Figure 17. Install pin to hinge and secure with C-clip.
- Install saddlebag lid to base by aligning hinge halves and close lid. Pull up on front of lid to make sure lid is fastened securely.

Final Assembly

⚠ WARNING

Connect positive (+) battery cable first. If positive (+) cable should contact ground with negative (-) cable connected, the resulting sparks can cause a battery explosion, which could result in death or serious injury. (00068a)

- Connect battery cables, positive (+) cable first.

⚠ WARNING

After installing seat, pull upward on seat to be sure it is locked in position. While riding, a loose seat can shift causing loss of control, which could result in death or serious injury. (00070b)

- Install seat according to the instructions in the Service Manual.

⚠ WARNING

Be sure that all lights and switches operate properly before operating motorcycle. Low visibility of rider can result in death or serious injury. (00316a)

- Check turn signals for proper operation.
- Check tail light for proper operation.

SERVICE PARTS

is03269

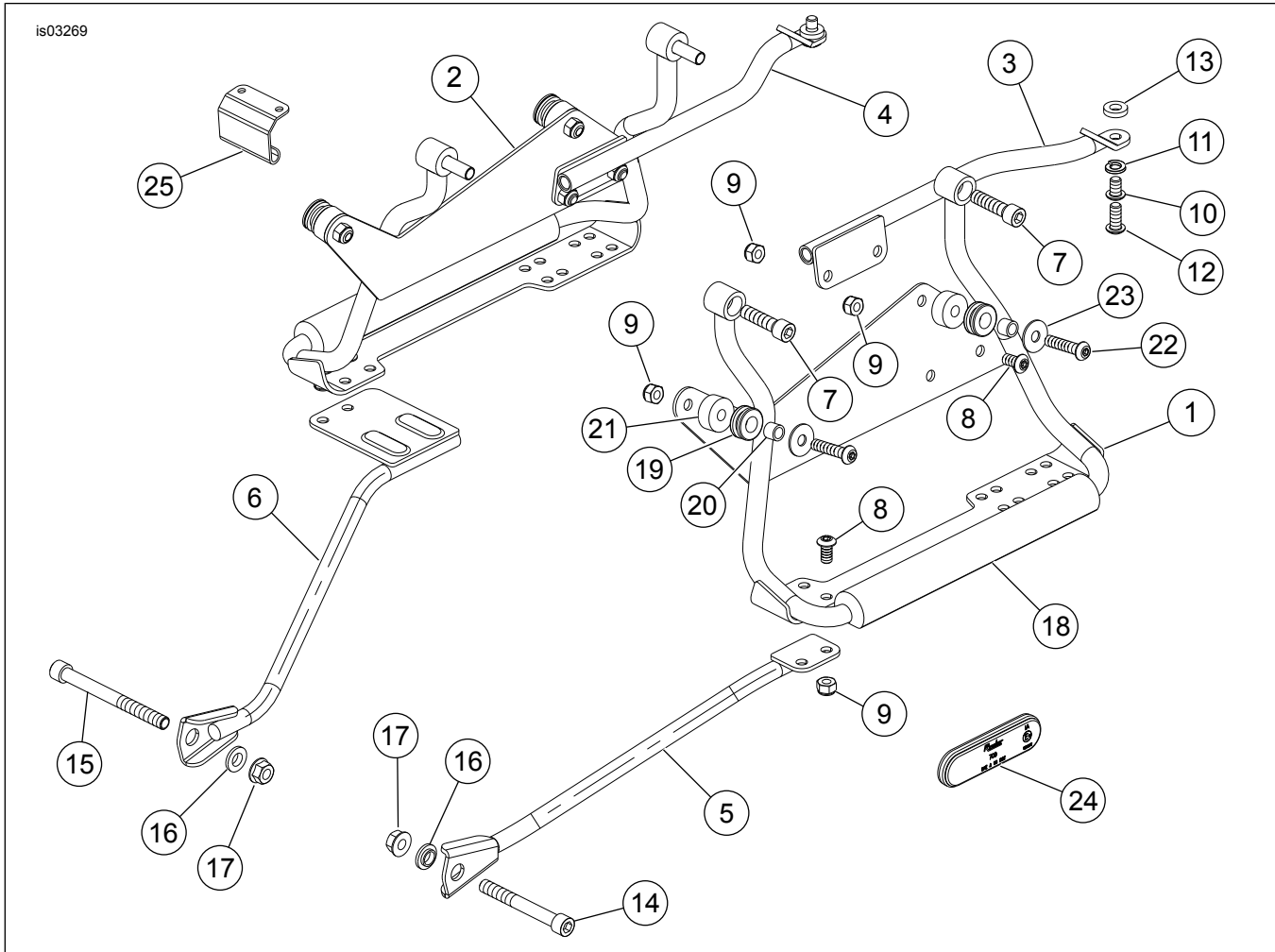

Figure 18. Service Parts: Saddlebag Bracket Kit (90715-07) and Hardware Kit (88208-07)

Table 2. Service Parts Table

Item	Description (Quantity)	Part Number	Item	Description (Quantity)	Part Number
Kit 90715-07XX					
Kit 88205-07A - Saddlebag Bracket Kit					
Includes items 1 through 6					
1	Hanger, saddlebag support L.H.	90762-00	13	Spacer (2) (2-3/8 in. turn signal)	65849-01
2	Hanger, saddlebag support R.H.	90750-00	14	Bolt, 3/8-16 x 3 in.	94362-91T
3	Relocation bracket, L.H.	90695-00	15	Bolt, 3/8-16 x 4 in.	4204
4	Relocation bracket, R.H.	90433-00	16	Washer, shoulder (2)	5816
5	Bracket, forward support L.H.	88207-07	17	Locknut, 3/8-16 (2)	7601
			18	Isolator, support	90267-00
			6	Bracket, forward support R.H.	88206-07A
Kit 88208-07 - Saddlebag Bracket Hardware Kit					
Includes items 7 through 25					
7	Bolt, 5/16-18 x 1-3/8 in. (4)	1002	20	Spacer, steel (4)	90186-00A
8	Screw, 5/16-18 x 5/8 in. (8)	3540	21	Spacer (4)	90175-00
9	Locknut, 5/16-18 (8)	7739	22	Screw, 5/16-18 x 1-3/8 in. (4)	4214
10	Screw, 5/16-24 x 1/2 in. (3 in. turn signal)	3538	23	Washer, 5/16 (4)	6213
			24	Reflector, red (2)	59173-00

① ② ③
④ ⑤ ⑥
⑦ ⑧ ⑨
⑩ ⑪ ⑫
⑬ ⑭ ⑮
⑯ ⑰ ⑱
⑲ ⑳ ㉑
㉒ ㉓ ㉔
㉕ ㉖ ㉗
㉘ ㉙ ㉚
㉛ ㉜ ㉝
㉞ ㉟ ㊱
㊲ ㊳ ㊴
㊵ ㊶ ㊷
㊸ ㊹ ㊺

Table 2. Service Parts Table

Item	Description (Quantity)	Part Number	Item	Description (Quantity)	Part Number
11	Lockwasher (2) (2-3/8 and 3 in. turn signals)	7041	25	Hinge (2)	90229-00
12	Screw, 5/16-18 x 3/4 in. (2) (2-3/8 in. turn signal)	4092			

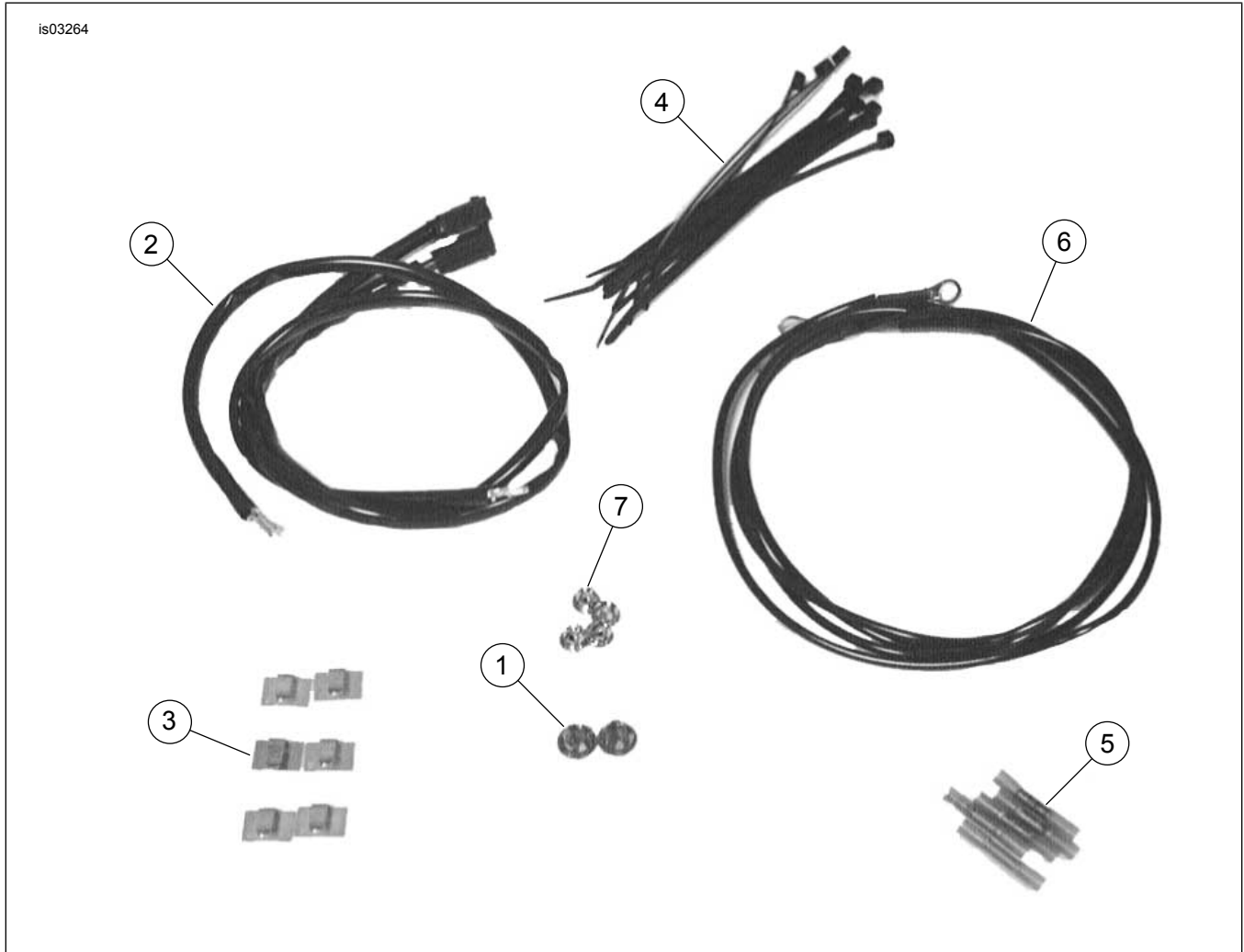

Figure 19. Service Parts: Turn Signal Wiring Kit (72509-00)

Table 3. Service Parts Table

Item	Description (Quantity)	Part Number
1	Chrome plug (2)	53830-00
2	Wire harness (2)	70508-00
3	Clip, adhesive (8)	10102
4	Strap, cable (6)	10006
5	Connector, sealed butt (5)	70586-93
6	Strap, ground (2)	70507-00
7	Plug, button (4)	68446-00

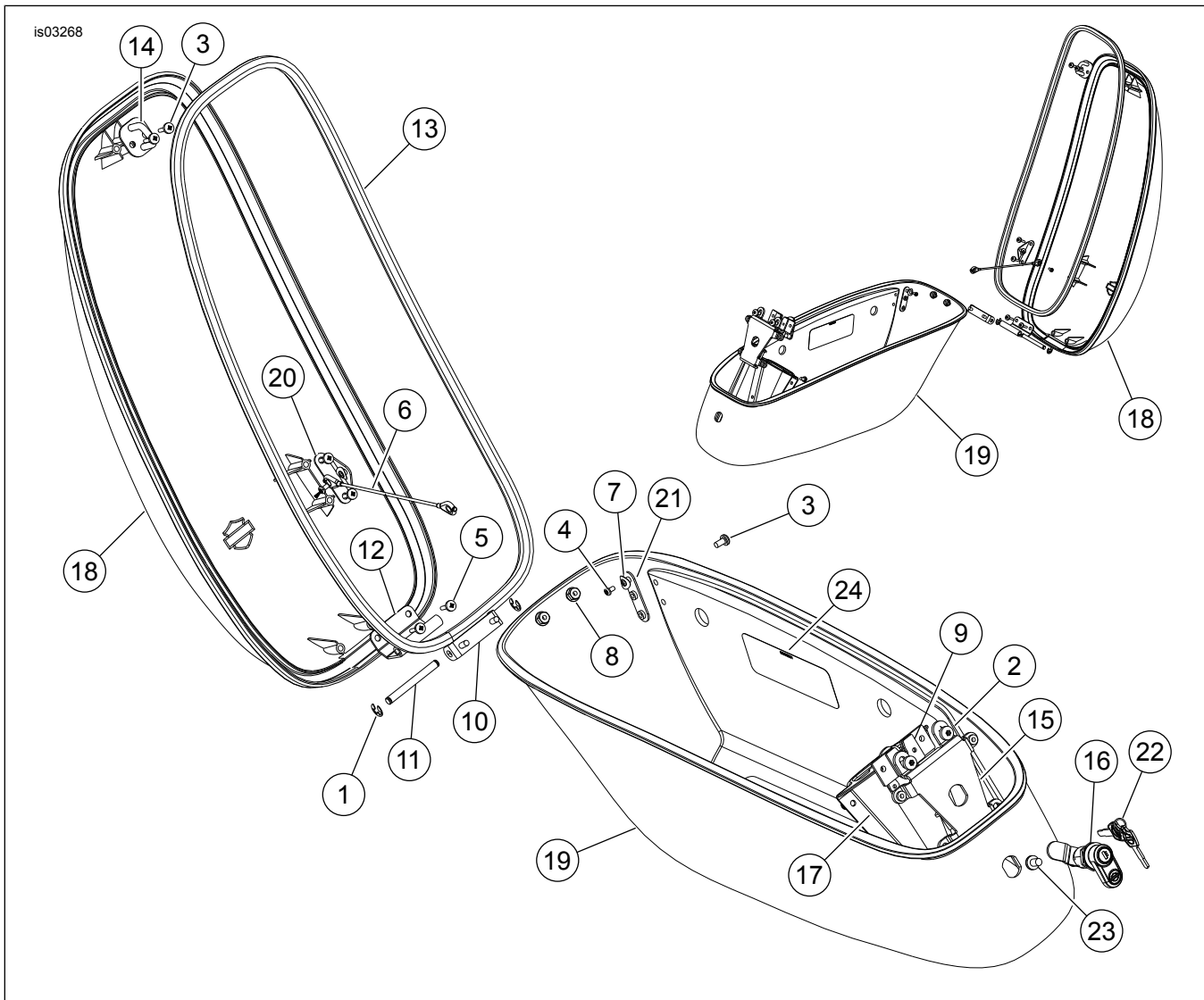

Figure 20. Service Parts: Saddlebag Assemblies (90026-07XX L.H. and 90027-07XX R.H.)

Table 4. Service Parts Table

Item	Description (Quantity)	Part Number	Item	Description (Quantity)	Part Number
	Saddlebag assembly, L.H. (includes Items 1 through 24)	20026-07XX	13	Gasket	90230-00
	Saddlebag assembly, R.H. (includes Items 1 through 24)	20027-07XX	14	Loop latch	90231-00
1	Retaining ring	11015	15	Bracket, latch	90232-00
2	Screw, M6-6H (2)	1394	16	Lockset, saddlebag	90235-00A
3	Screw, #10-24 x 3/8 in. (6)	3018	17	Cover latch assembly	90237-00
4	Screw, pan head machine (2)	3595	18	Lid, saddlebag (left)	90261-00
5	Screw, hi-lo (8)	3596		Lid, saddlebag (right)	90260-00
6	Tether	53633-00	19	Base, saddlebag (left)	90264-00
7	Washer, spring curved (2)	6970		Base, saddlebag (right)	90262-00
8	Nut, flange (2)	7878	20	Bracket, upper tether	90417-00
9	Latch assembly	90166-00	21	Bracket, lower tether	90418-00
10	Catch, hinge	90172-00	22	Key set (specify code)	90234-00
11	Pin	90173-00	23	Screw, TORX T30 1/4-20 x 3/8 in.	Not Sold Separately
12	Hinge, hook bracket	90176-00	24	Label, saddlebag (location shown)	Not Sold Separately