



INSTRUCTIONS

J04763

2008-04-11



INNER FAIRING TRIM PACKAGE KIT

GENERAL

Kit Number

96396-09

Models

For model fitment information, see the P&A Retail Catalog or the Parts and Accessories section of www.harley-davidson.com (English only).

Kit Contents

See Table 1.

Additional Parts Required

This instruction sheet references Service Manual information. A Service Manual for your model motorcycle is required for this installation and is available from a Harley-Davidson Dealer.

PREPARATION

Preparation for All Trim Pieces

NOTE

Mounting surfaces must be above 60°F (16°C), or the trim piece may not adhere.

- Using a 50:50 isopropyl alcohol/water solution, thoroughly clean the surface where the trim will be installed for each kit component.

NOTICE

Do not clean with denatured alcohol, mineral spirits, or other solvent products, or component damage may occur. (00411c)

- Allow the surface to dry completely before continuing to install kit.

NOTE

Trim rings cannot be repositioned after initial installation. Verify they are properly aligned before pressing into place.

- Test the fit of the trim piece prior to removing adhesive backing of the double-sided tape or the trim piece.

NOTE

Let the adhesive cure for at least 24 hours at no less than 60°F (16°C).

INSTALLATION

Install Small Instrument Bezel Covers

- See Figure 1. Cut tape (1) into six equal pieces.
- Remove paper liner from one side of tape and apply three pieces tape (spaced equally) to the instrument bezel (2). Press firmly.
- Remove the adhesive backing from the back of the double-sided tape.
- Position instrument bezel cover (3) over gauge and press firmly into place.
- Repeat for remaining gauges.

Install Large Instrument Bezel Covers

- See Figure 1. Cut tape (4) into sixteen equal pieces. Use eight pieces for each bezel cover.
- Repeat Steps 2 through 5 under "Install Small Instrument Bezel Covers".

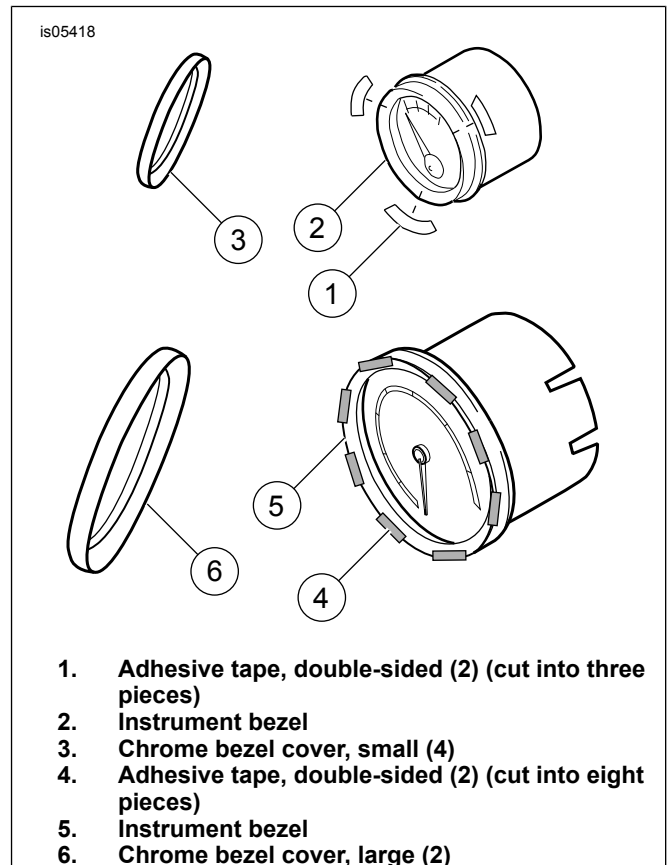

Figure 1. Install Instrument Bezels

Install Front Speaker Trim

1. Gently brush or vacuum each speaker grille to remove any dust or dirt particles.
2. Cut eight 1-inch strips of narrow masking tape.
3. Without removing the adhesive backing, position the trim rings against the speaker grille.
4. Rotate the trim rings into desired position and hold in place.
5. See Figure 2. Apply 4 pieces of masking tape (1) directly to the speaker grille above and below the trim ring crossbar and on each side of the Bar & Shield. This will be the installation template.
6. Remove the adhesive backing from the trim ring.
7. Align the trim ring with the masking tape template and press firmly into place.
8. Remove masking tape template.
9. Repeat for the other speaker.

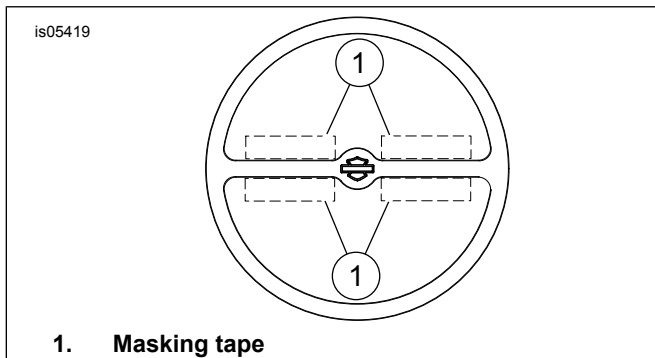

Figure 2. Speaker Grille Cover

Install Radio Faceplate

1. See Figure 3. Test the fit of the radio faceplate trim before removing the adhesive backing.
2. Remove the adhesive backing from the back of the radio faceplate trim.
3. Open the auxiliary jack cap and feed it through the radio faceplate trim (1). Position radio faceplate and press firmly into place.

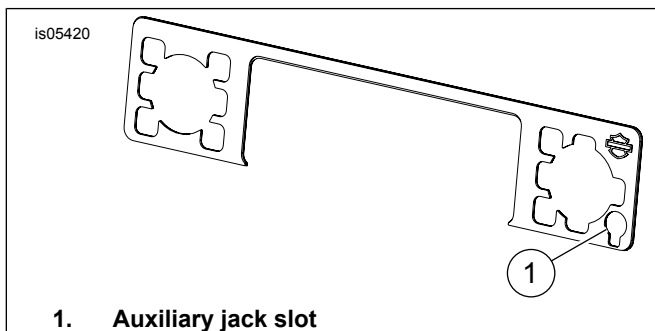

Figure 3. Radio Faceplate Trim

Install Radio/Gauge Bezel

1. Insert a CD into the radio, press the EJECT button and turn the motorcycle switch to OFF.
2. Test the fit of the radio bezel before removing the adhesive backing.

3. Remove the adhesive backing from the back of the radio bezel.

NOTE

When bezel is aligned properly, the CD door will open without rubbing against the bezel.

4. See Figure 4. Install the bezel aligning the opening in the bezel (1) with the indicator lights and verifying that the CD door opens without rubbing against the bezel.
5. Measure the distance between the door and the CD (2). If the distance is 1/8 inch or more, the installation is complete. If the distance is less than 1/8 inch, proceed to Step 6.
6. Remove the outer fairing following the instructions in the appropriate Service Manual.
7. Loosen the four radio mounting screws and push the radio toward the rear of the motorcycle to the maximum position within the mounting slots.
8. Tighten the four mounting screws.
9. Measure the distance between the door and the CD again.
10. Install the outer fairing following the instruction in the appropriate Service Manual.

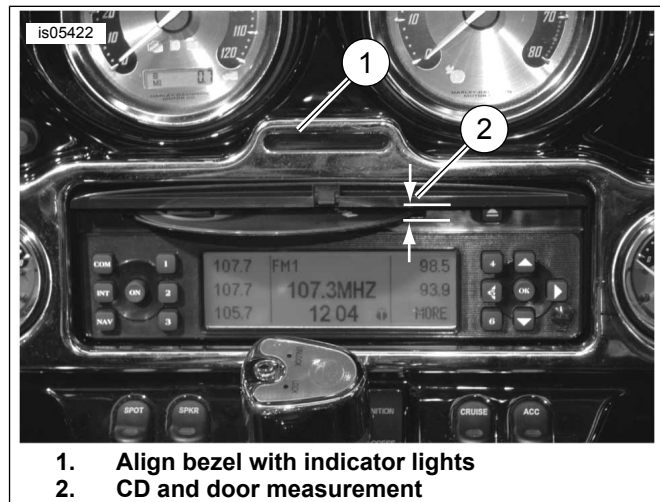

Figure 4. Install Radio/Gauge Bezel

SERVICE PARTS

Table 1. Kit Contents

Item	Description (Quantity)	Part Number
1	Gauge bezel cover, small (4) • Tape, double-sided (included with Item 1)	74550-92T (set of 2) Not Sold Separately
2	Gauge bezel cover, large (2) • Tape, double-sided (included with Item 2)	74541-00 Not Sold Separately
3	Front speaker trim (2)	74604-99
4	Radio faceplate	77143-07
5	Radio/gauge bezel	74612-06