



INSTRUCTIONS

J04287

2007-01-29



AUXILIARY LAMP KIT

GENERAL

Kit Number

69287-07

Models

For model fitment information, please see the P&A Retail Catalog or the Parts and Accessories section of www.harley-davidson.com (English only).

Additional Parts Required

Proper installation of this kit requires the following tools which are available at a Harley-Davidson dealer:

- Heat Gun (HD-25070)
- Packard Crimping Tool (HD-38125-8)
- Ultra-Torch (HD-39969)

⚠ WARNING

Rider and passenger safety depend upon the correct installation of this kit. Use the appropriate service manual procedures. If the procedure is not within your capabilities or you do not have the correct tools, have a Harley-Davidson dealer perform the installation. Improper installation of this kit could result in death or serious injury. (00333b)

NOTE

This instruction sheet references Service Manual information. A Service Manual for your model motorcycle is required for this installation and is available from a Harley-Davidson dealer.

Kit Contents

See Figure 5 and Table 1.

NOTICE

It is possible to overload the vehicle's charging system by adding too many electrical accessories. If the combined electrical accessories operating at any one time consume more electrical current than the vehicle's charging system can produce, the electrical consumption can discharge the battery and cause damage to the vehicle's electrical system. (00211d)

NOTE

Auxiliary/fog lamps are not included in this kit. The desired style of lamp must be purchased separately. HDI motorcycles should only use approved fog lamps.

If this lamp kit will be used with a windshield kit, refer to the instructions provided with that kit for the correct mounting sequence.

INSTALLATION

Install Auxiliary Lamp and Bracket

1. See Figure 1. Remove and discard two screws (1) and side trim strips (2) from each side of the fork trim panel (3).

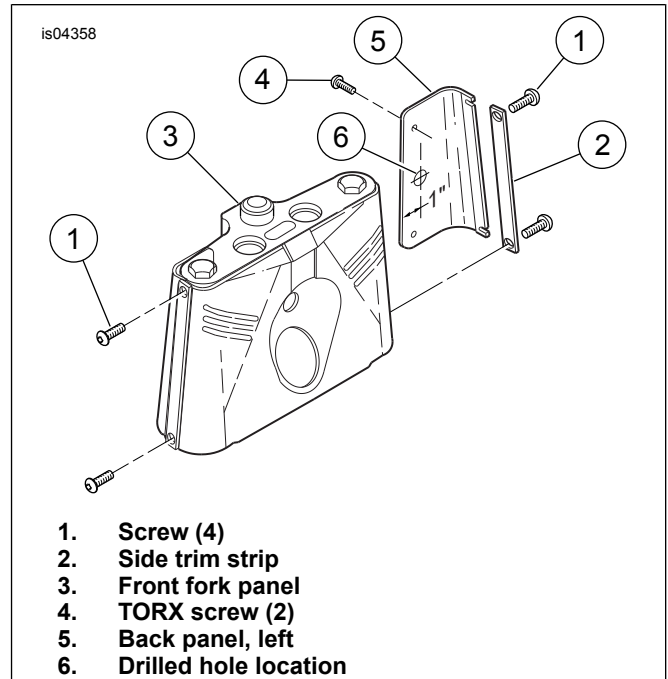

Figure 1. Toggle Switch Hole

2. Unfasten TORX[®] screws (4) and remove back panel (5) from front fork trim panel.
3. Mark a spot one inch out from the inside edge and halfway between the top and bottom edges of the back panel.
4. Drill a small lead hole (6) at the location indicated. Enlarge the hole to 1/2 in. (13 mm) diameter.
5. See Figure 5. Attach adhesive label (1) around drilled hole (Figure 1, Item 6). Mount toggle switch (2) in hole using knurled nut (3). Set back panel aside for later wiring.
6. Place lockwasher (4) and washer (5) on two bolts (6). Insert bolts through upper holes in bracket (7) and through spacer (8). Thread into upper holes of fork bracket and through trim panel finger tight.

- Place lockwasher (4) and washer (5) on two bolts (9). Insert bolts through lower holes in bracket (7) and through spacer (10). Thread into bottom holes of fork bracket and through trim panel finger tight.
- Tighten right side bolts on bracket to 19 ft-lbs (26 Nm).
- Attach auxiliary lamp housing (11) to bracket using hardware (12-16) in the sequence shown in Figure 5.

NOTE

The Belleville washer (13) must be positioned cupped side up.

- See Figure 2. Place inner nesting ring on bulb. Connect back wire to spade terminal next to bulb index tab (1). Install gray wire on remaining spade terminal.

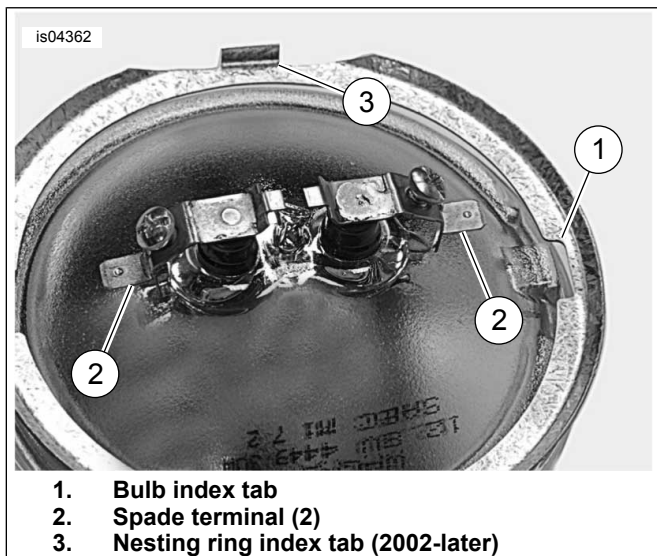

- Bulb index tab
- Spade terminal (2)
- Nesting ring index tab (2002-later)

Figure 2. Auxiliary Lamp Bulb Terminal

- Attach auxiliary lamp (17) and inner nesting ring (18) using outer trim ring (19), screw (20), and nut (21).

Auxiliary Lamp Wiring

- Remove seat according to the instructions in the Service Manual.

▲ WARNING

To prevent accidental vehicle start-up, which could cause death or serious injury, disconnect battery cables (negative (-) cable first) before proceeding. (00307a)

▲ WARNING

Disconnect negative (-) battery cable first. If positive (+) cable should contact ground with negative (-) cable connected, the resulting sparks can cause a battery explosion, which could result in death or serious injury. (00049a)

- Disconnect battery cables, negative (-) cable first.

- See Figure 3. Combine wire ends from both auxiliary lamps (1) and terminate them with one of the spade terminals (Figure 5, Item 22).
- Attach connector (2) to the nearest terminal on the toggle switch (3).

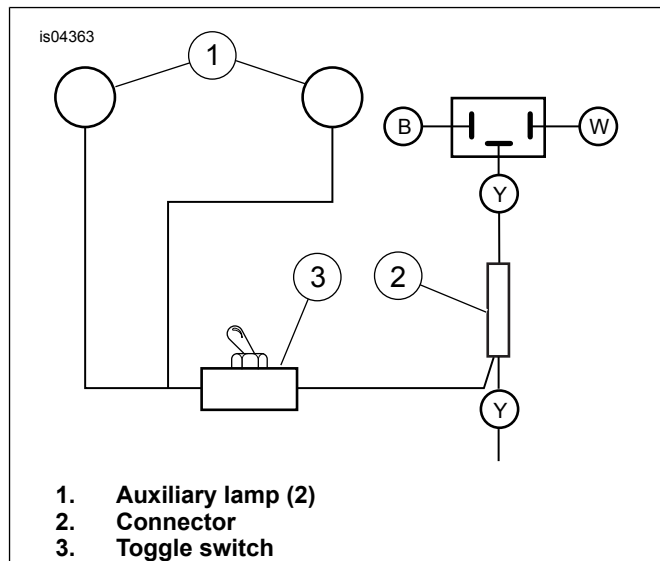

- Auxiliary lamp (2)
- Connector
- Toggle switch

Figure 3. Wiring Diagram

- See Figure 5. Terminal one end of cable wire (23) with remaining single spade connector (22) and attach connector to remaining terminal on toggle switch (2). Slide conduit (24) over cable wire.
- See Figure 1. Attach left side panel (5) to front fork panel (3) under left side of auxiliary lamp bracket.
- Route wires so they are not pinched between the trim panel and fork bracket. Use cable straps (25) to secure wires to fork bracket and motorcycle frame.
- Tighten left side bolts on bracket to 19 ft-lbs (26 Nm).
- See Figure 5. Remove outer trim ring (21) and auxiliary lamp (17).
- Route end of toggle switch wire into headlamp housing (11) through grommet in rear of housing. Refer to HEADLAMP REMOVAL/INSTALLATION in Service Manual.

NOTE

To route the wire through the grommet, push a hooked piece of wire through the grommet from the inside of the headlamp housing. Soap the toggle switch wire and pull it back through back through the grommet with the hooked wire.

When wired as follows, the auxiliary lamps can only be operated while the main headlamp is on low beam. This conforms to most state and local laws.

Butt Splice Connections

- See Figure 3. Connect toggle switch lead to the low beam (yellow) wire from headlamp socket with butt splice connector (Figure 5, Item 26) from kit.

- Cut low beam (yellow) wire several inches from headlamp connector.
- Strip a 3/8 in. (10 mm) section of insulation from ends of three wires being spliced.
- See Figure 4. Insert wires into ends of butt splice connector.

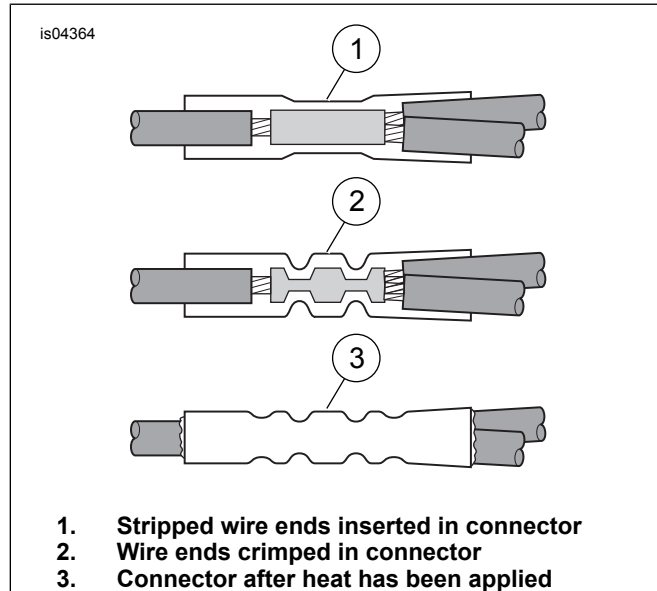

Figure 4. Install Butt Splice Connectors

- Match color of butt splice connector with cavity of crimping tool. Using a Packard Crimping Tool, crimp wires into the connector.

⚠ WARNING

Be sure to follow manufacturer's instructions when using the UltraTorch UT-100 or any other radiant heating device. Failure to follow manufacturer's instructions can cause a fire, which could result in death or serious injury. (00335a)

- Avoid direct heat toward any fuel system component. Extreme heat can cause fuel ignition/explosion resulting in death or serious injury.

- Avoid direct heat toward any electrical system component other than the connectors on which heat shrink work is being performed.
 - Always keep hands away from tool tip area and heat shrink attachment.
- Using Ultra-Torch, Heat Gun, or other suitable radiant heating device, heat crimped splice to encapsulate butt splice connection. Apply heat from the center of the crimp out to each end until meltable sealant exudes out of both ends of connector. Let splices cool.

Final Assembly

- Assemble headlamp components.

⚠ WARNING

Connect positive (+) battery cable first. If positive (+) cable should contact ground with negative (-) cable connected, the resulting sparks can cause a battery explosion, which could result in death or serious injury. (00068a)

- Connect battery cables, positive (+) first.
- Install seat according to the instructions in the Service Manual.

⚠ WARNING

After installing seat, pull upward on seat to be sure it is locked in position. While riding, a loose seat can shift causing loss of control, which could result in death or serious injury. (00070b)

⚠ WARNING

Be sure that all lights and switches operate properly before operating motorcycle. Low visibility of rider can result in death or serious injury. (00316a)

- Test headlamp high and low beams, and the auxiliary lamps for proper operation. Refer to HEADLAMP ALIGNMENT in Service Manual.
- Aim auxiliary lamps and tighten mounting nuts.

SERVICE PARTS

is04365

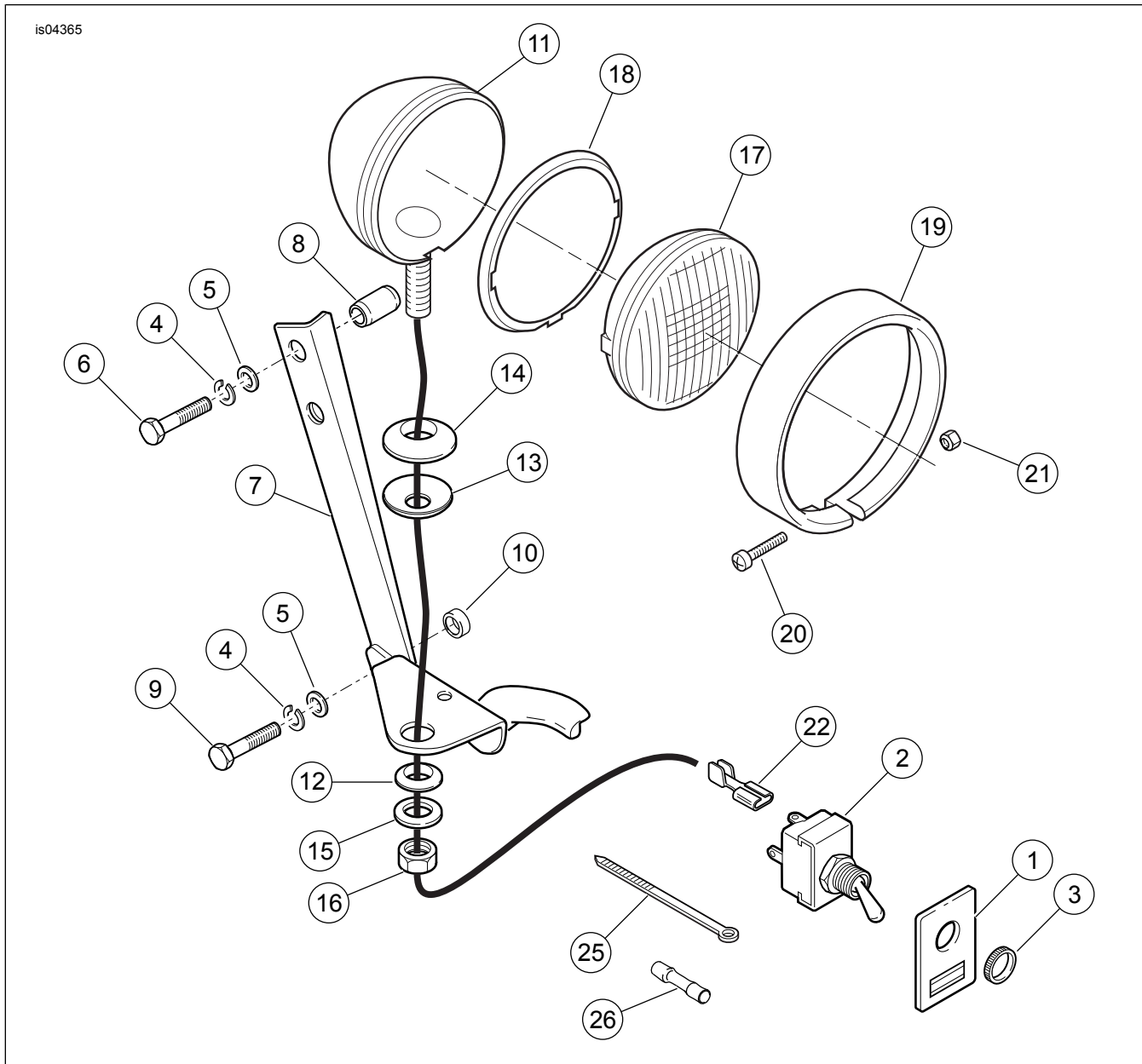

Figure 5. Service Parts: Auxiliary Lamp Kit

Table 1. Service Parts Table

Item	Description (Quantity)	Part Number
1	Label, switch	68731-98
2	Switch, toggle (includes Item 3, knurled nut)	67844-70
3	Nut, knurled	67846-70
4	Lockwasher, 5/16 in. (6)	7041
5	Washer, flat 5/16 in.	6330
6	Bolt, 5/16-24 x 1-3/8 in. (2)	4020W
7	Bracket, auxiliary lamp	57852-02A
8	Spacer (2)	5885
9	Bolt, 5/16-24 x 1 in. (2)	3960W
10	Spacer (2)	11827
11	Housing, auxiliary lamp (2)	68683-02
12	Clamp block, auxiliary lamp (2)	68720-62
13	Washer, Belleville (2)	6072
14	Swivel block, auxiliary lamp (2)	68721-62
15	Washer, swivel (2)	68693-38

Table 1. Service Parts Table

Item	Description (Quantity)	Part Number
16	Locknut, 3/8-16 (2)	7778
17	Auxiliary lamp (sealed unit) (2)	Purchased Separately
18	Nesting ring, inner	68331-02
19	Trim ring, outer	68725-62A
20	Screw, #8-32 x 1 in.	3514
21	Locknut, #8-32 (chrome)	7606
22	Connector, single spade (2)	9930
23	Wire, cable (not shown)	Not Sold Separately
24	Conduit (not shown)	Not Sold Separately
25	Strap, cable (10)	10006
26	Connector, butt splice	70586-93