



# INSTRUCTIONS

J04291

2014-09-12



## CHROME CLUTCH BRACKET AND FRONT BRAKE MASTER CYLINDER RESERVOIR KIT

### GENERAL

#### Kit Number

42117-08A

#### Models

For model fitment information, see the P&A Retail Catalog or the Parts and Accessories section of [www.harley-davidson.com](http://www.harley-davidson.com) (English only).

#### NOTE

*Installation of this kit requires the installation of brake and clutch hand control levers. If replacement of the original equipment (OE) levers is needed, refer to the Parts Catalog for your year and model vehicle.*

*See the P&A Retail Catalog or the Parts and Accessories section of [www.harley-davidson.com](http://www.harley-davidson.com) (English only) for a selection of Genuine Motor Accessory hand control levers that are available. These can be easily installed at the same time as this kit.*

#### Additional Parts Required

A Brake Lever Pivot Pin Kit (Part Number 42860-06B, black OR 42105-06A, polished) and a retaining ring (Part Number 11143) for the **clutch lever** pivot pin are required for the proper installation of this kit.

#### Tools and Supplies Required

Fresh, uncontaminated DOT 4 brake fluid from a sealed container will be needed. GM-40M grease (2 gram bag, H-D part number 42820-04) will also be needed. These items are available from a Harley-Davidson Dealer.

#### ⚠ WARNING

Rider and passenger safety depend upon the correct installation of this kit. Use the appropriate service manual procedures. If the procedure is not within your capabilities or you do not have the correct tools, have a Harley-Davidson dealer perform the installation. Improper installation of this kit could result in death or serious injury. (00333b)

#### NOTE

*This instruction sheet references Service Manual information. A Service Manual for your model motorcycle is required for this installation and is available from a Harley-Davidson Dealer.*

#### ⚠ WARNING

Brakes are a critical safety component. Contact a Harley-Davidson dealer for brake repair or replacement. Improperly serviced brakes can adversely affect brake performance, which could result in death or serious injury. (00054a)

#### Kit Contents

See Figure 5 and Table 1.

### INSTALLATION

Rest the motorcycle on the jiffy stand, with the front wheel turned toward the right fork stop so that the master cylinder is in a level position.

#### Front Brake Master Cylinder Removal

#### ⚠ WARNING

Contact with DOT 4 brake fluid can have serious health effects. Failure to wear proper skin and eye protection could result in death or serious injury.

- If inhaled: Keep calm, remove to fresh air, seek medical attention.
- If on skin: Remove contaminated clothing. Rinse skin immediately with plenty of water for 15-20 minutes. If irritation develops, seek medical attention.
- If in eyes: Wash affected eyes for at least 15 minutes under running water with eye lids held open. If irritation develops, seek medical attention.
- If swallowed: Rinse mouth and then drink plenty of water. Do not induce vomiting. Contact Poison Control. Immediate medical attention required.
- See Safety Data Sheet (SDS) for more details available at [sds.harley-davidson.com](http://sds.harley-davidson.com)

(00240e)

#### NOTICE

DOT 4 brake fluid will damage painted and body panel surfaces it comes in contact with. Always use caution and protect surfaces from spills whenever brake work is performed. Failure to comply can result in cosmetic damage. (00239c)

**IMPORTANT NOTE:** If DOT 4 brake fluid contacts painted surfaces, IMMEDIATELY flush area with clear water.

Cover nearby motorcycle surfaces with a polyethylene protective sheet to help protect against damage to finish caused by spillage or splash of DOT 4 brake fluid.



1. Drain the front brake master cylinder.
  - a. Open the bleeder nipple caps on each of the front brake calipers.
  - b. Install one end of a length of clear plastic tubing over each caliper bleeder valve, while placing the free ends in a suitable container.
  - c. Open the bleeder valves about 3/4-turn. Pump the hand lever to drain the fluid from the reservoir.
  - d. Close the bleeder valves.

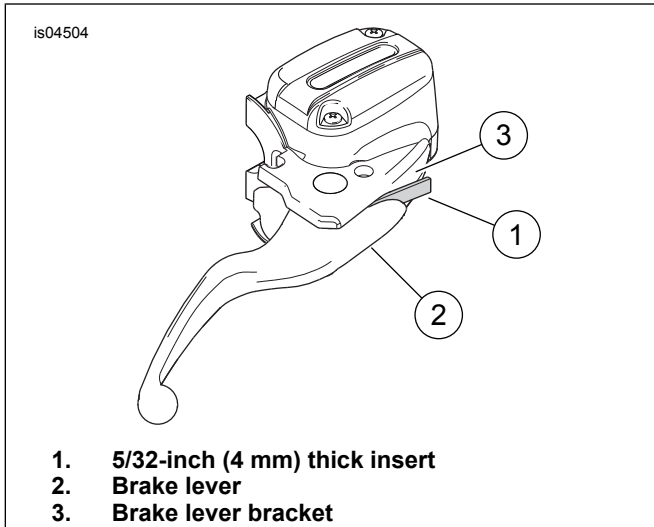

**Figure 1. Protect Stop Light Switch**

2. **FLHRS/FLHRSE models:** Remove the mirror and front turn signal from the brake hand lever bracket. **All other models:** Remove the mirror from the brake hand lever bracket.
  - a. Remove the acorn nut, lockwasher and (if equipped) turn signal lamp bracket from the mirror stem. Secure the turn signal lamp to the handlebar.
  - b. Remove the threaded stem of the mirror from the brake lever bracket, and set aside for reassembly.
3. Clean the area surrounding the banjo bolt at the front brake master cylinder. Remove the banjo bolt and the two copper gaskets to disconnect the brake line fitting from the master cylinder. Discard the gaskets, but save the banjo bolt.

**NOTE**

Use the eyelet of a cable strap if the cardboard insert is not available. See Figure 1.

**NOTICE**

**Do not remove or install the master cylinder assembly without first positioning a 5/32-inch (4 mm) thick insert between the brake lever and lever bracket. Removing or installing the master cylinder assembly without the insert in place may result in damage to the rubber boot and plunger on the front stoplight switch. (00324a)**

4. Place cardboard insert between brake lever and brake lever bracket.
5. See Figure 5. Using a T-27 TORX<sup>®</sup> drive head, remove and discard the two screws (3) and flat washers (4) securing the handlebar clamp (2) to the master cylinder housing (7). Remove the brake lever/master cylinder assembly and clamp from the handlebar.

**If the current brake lever WILL NOT be re-used with the new master cylinder:** Continue after Step 6.

**If the current brake lever IS being re-used with the new master cylinder:**

**⚠ WARNING**

**Wear safety glasses or goggles when removing or installing retaining rings. Retaining rings can slip from the pliers and could be propelled with enough force to cause serious eye injury. (00312a)**

6. Remove and discard the retaining ring (C) from the groove in the pivot pin (B). Remove and discard the pivot pin.
7. Remove the brake hand lever (A) from the master cylinder.

**NOTE**

The new master cylinder comes with all internal components pre-assembled. It is not necessary to remove the components from the bore of the old master cylinder.

**New Front Brake Master Cylinder Installation**

1. Obtain the OE brake hand lever removed earlier, or a new lever (purchased separately). Apply a small amount of GM-40M grease (H-D part number 42820-04) to the area where the master cylinder pushrod seats against the brake lever. **DO NOT** apply grease to the stop-light switch contact surface of the lever. Align the hole in the brake hand lever with the hole in the **new** master cylinder bracket. From the top of the assembly, slide the **new** pivot pin (purchased separately) down through the bracket and hand lever. Check that the pushrod is properly seated on the lever.

**⚠ WARNING**

**Wear safety glasses or goggles when removing or installing retaining rings. Retaining rings can slip from the pliers and could be propelled with enough force to cause serious eye injury. (00312a)**

2. Install the **new** retaining ring (purchased separately) in the pivot pin groove. Verify that the retaining ring is completely seated in the groove.

**NOTE**

Use the eyelet of a cable strap if the cardboard insert is not available. See Figure 1

## NOTICE

Do not remove or install the master cylinder assembly without first positioning a 5/32-inch (4 mm) thick insert between the brake lever and lever bracket. Removing or installing the master cylinder assembly without the insert in place may result in damage to the rubber boot and plunger on the front stoplight switch. (00324a)

3. Place cardboard insert between brake lever and brake lever bracket.

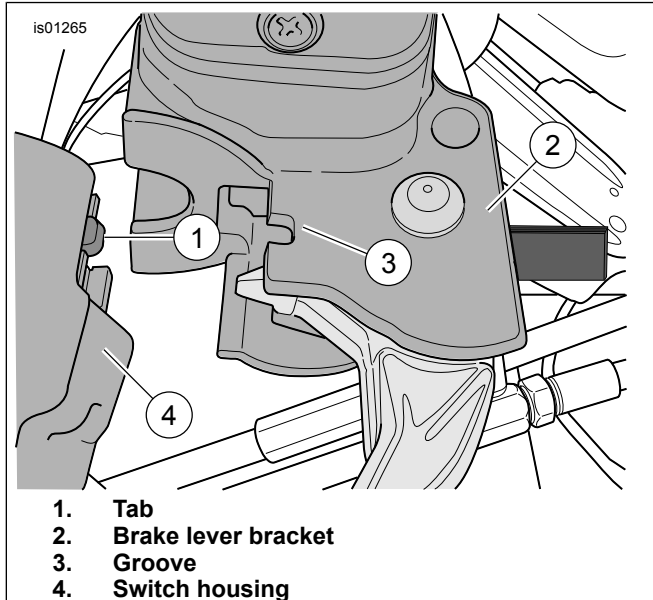

Figure 2. Brake Lever Bracket to Switch Housing

4. See Figure 2. Position the brake lever/master cylinder assembly inboard of the switch housing (4) assembly, engaging the tab (1) on the lower switch housing in the groove (3) at the top of the brake lever bracket (2).
5. Obtain the **new** screws (3) and flat washers (4) from the kit. Place a washer onto the threads of each screw. Align the holes in the **new** handlebar clamp with those in the master cylinder housing, and start the two screws into the threaded holes.
6. Adjust the position of the brake lever assembly on the handlebar for rider comfort and posture. Beginning with the top screw, use a T27 TORX drive head to tighten the screws to 7.9–9 N·m (70–80 in-lbs).

## NOTICE

Avoid leakage. Be sure gaskets, banjo bolt(s) and brake line are clean and undamaged before assembly. (00323a)

7. Position **new** copper gaskets (6, included in the kit) on each side of the brake line fitting. Insert the **new** banjo bolt (5) through the gaskets and fitting. Thread the bolt into the master cylinder housing and tighten to 17–20 N·m (13–15 ft-lbs).
8. Remove the insert from the brake lever. See Figure 1

## Clutch Bracket and Lever Removal

Park motorcycle on a level surface on jiffy stand.

1. **FLHRSE/FLHRSE models:** Remove the mirror and front turn signal from the clutch hand lever bracket. **All other models:** Remove the mirror from the clutch hand lever bracket.
  - a. Remove the acorn nut, lockwasher and (if equipped) turn signal lamp bracket from the mirror stem. Secure the turn signal lamp to the handlebar.
  - b. Remove the threaded stem of the mirror from the clutch lever bracket, and set aside for reassembly.
2. See Figure 3. Loosen the clutch adjuster so the clutch cable is fully slack by performing the following steps:
  - a. Slide the rubber boot (1) off the cable adjuster (2).
  - b. Holding the cable adjuster with a 1/2 in wrench, loosen the jamnut (3) using a 9/16 in wrench.
  - c. Back the jamnut away, and turn the cable adjuster toward the jamnut to cause a large amount of free play at the clutch hand lever.

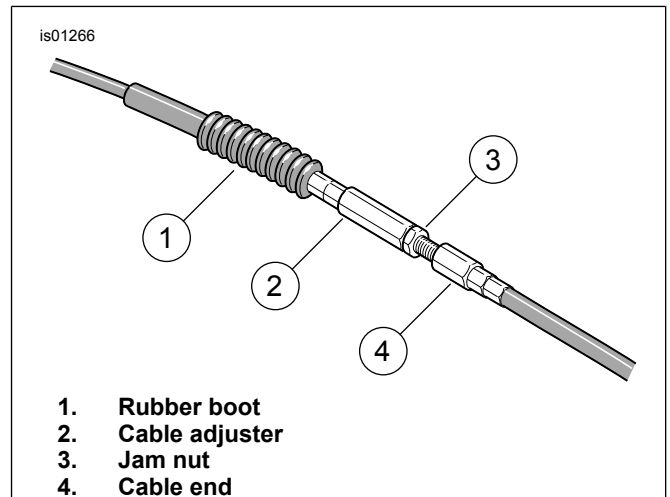

Figure 3. Loosen Clutch Adjuster

### ⚠ WARNING

Wear safety glasses or goggles when removing or installing retaining rings. Retaining rings can slip from the pliers and could be propelled with enough force to cause serious eye injury. (00312a)

3. See Figure 5. Remove and **discard** the retaining ring (G) from the pivot pin (F). Remove and **retain** the pin from the clutch lever bracket (1).
4. Remove the clutch cable anchor pin (I) from the clutch hand lever (D). Remove the clevis end of the clutch cable (H) and the hand lever from the bracket.
5. Using a T-27 TORX<sup>®</sup> drive head, remove and discard the two screws (3) and flat washers (4) securing the handlebar clamp (2) to the clutch lever bracket. Remove the clutch lever bracket and clamp from the handlebar.

## New Clutch Bracket and Lever Installation

1. See Figure 5. Obtain the OE clutch hand lever (D) removed earlier, or a new lever (purchased separately). Verify that the pivot bushing (E) is in place.
2. Place the clevis end of the clutch cable (H) in position in the clutch lever, and slide the anchor pin (I) into place. The flat in the pin must face in toward the hand lever.

### ⚠ WARNING

**Wear safety glasses or goggles when removing or installing retaining rings. Retaining rings can slip from the pliers and could be propelled with enough force to cause serious eye injury. (00312a)**

3. Place the clutch lever in the new bracket, and install the pivot pin (F) saved earlier and the **new** retaining ring (G), purchased separately.
4. Obtain the **new** screws (3) and flat washers (4) from the kit. Place a washer onto the threads of each screw. Align the holes in the **new** handlebar clamp with those in the clutch lever bracket, and start the two screws into the threaded holes.
5. Adjust the position of the clutch lever assembly on the handlebar for rider comfort and posture. Beginning with the top screw, use a T-27 TORX drive head to tighten the screws to 7.9–9 N·m (70–80 in-lbs).

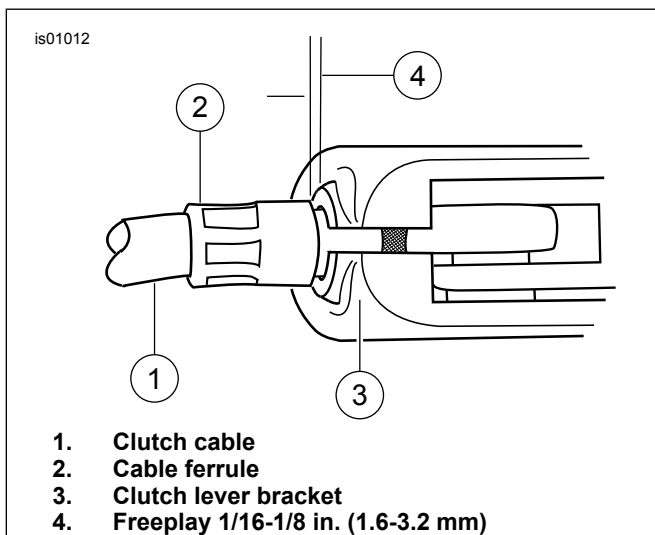

Figure 4. Clutch Hand Lever

6. Adjust the clutch lever free play by performing the following:
  - a. See Figure 3. Turn the cable adjuster (2) away from the jamnut (3) until slack is eliminated at the hand lever
  - b. See Figure 4. Pull the clutch cable ferrule (2) away from the clutch lever bracket (3) to check the free play. Turn the cable adjuster as necessary to obtain 1/16-1/8 inch (1.6-3.2 mm) free play between the end of the cable ferrule and the clutch lever bracket.

- c. See Figure 3. Hold the cable adjuster (2) with a 1/2 inch wrench. Using a 9/16 inch wrench, tighten the jamnut (3) against the adjuster.
- d. Cover the cable adjuster with the rubber boot (1).

## Final Assembly

### NOTE

**For ABS-equipped vehicles:** Refer to the Service Manual for brake bleeding procedures.

**For Non-ABS vehicles:** Refer to Steps 1 through 11 that follow.

1. If removed earlier, install one end of a length of clear plastic tubing over the **right-side** caliper bleeder valve, and place the free end in a suitable container. Verify that **both** caliper bleeder valves are closed tightly.
2. Remove the master cylinder cover. Rest the motorcycle on the jiffy stand, with the front wheel turned toward the right fork stop so that the master cylinder is level.

### ⚠ WARNING

**Contact with DOT 4 brake fluid can have serious health effects. Failure to wear proper skin and eye protection could result in death or serious injury.**

- **If inhaled:** Keep calm, remove to fresh air, seek medical attention.
- **If on skin:** Remove contaminated clothing. Rinse skin immediately with plenty of water for 15-20 minutes. If irritation develops, seek medical attention.
- **If in eyes:** Wash affected eyes for at least 15 minutes under running water with eye lids held open. If irritation develops, seek medical attention.
- **If swallowed:** Rinse mouth and then drink plenty of water. Do not induce vomiting. Contact Poison Control. Immediate medical attention required.
- See Safety Data Sheet (SDS) for more details available at [sds.harley-davidson.com](http://sds.harley-davidson.com)

(00240e)

### NOTE

*The brake system on this vehicle uses DOT 4 BRAKE FLUID. Do not mix grades of brake fluid as they are not compatible. Mixing different types of fluid may adversely affect braking ability and lead to brake failure which could result in death or serious injury.*

**IMPORTANT NOTE:** If DOT 4 brake fluid contacts painted surfaces, **IMMEDIATELY** flush area with clear water.

**Cover painted parts to protect finish.**

3. Add DOT 4 HYDRAULIC BRAKE FLUID to the master cylinder reservoir until the fluid level reaches the MAX marking inside the reservoir. Do not reuse old brake fluid. Use only D.O.T. 4 fluid from a sealed container.

### ⚠ WARNING

**Be sure the master cylinder relief port is not plugged. A plugged relief port can cause brake drag or lockup and loss of vehicle control, which could result in death or serious injury. (00317a)**

4. Verify proper operation of the master cylinder relief port by actuating the brake pedal or lever. Actuate the brake hand lever. A slight spurt of fluid will break the fluid surface in the reservoir compartment if all internal components are working properly.
5. Pump the front brake hand lever to build up hydraulic pressure.
6. **While holding the lever**, open the **right side** caliper bleeder valve about 3/4-turn. Brake fluid will flow from the bleeder valve through the tubing. Close the bleeder valve as soon as a loss of pressure is detected. Allow the brake hand lever to return slowly to its released position.

**NOTE**

*Pay careful attention to the fluid level in the master cylinder reservoir during the bleeding procedure. To avoid drawing air into the brake lines, always add fluid as needed to the reservoir before it becomes completely empty.*

7. Repeat Steps 5 and 6 until all air bubbles are purged, and a solid column of fluid is observed in the bleeder tube.
8. Final tighten the right-side bleeder valve to 9–11.3 N·m (80–100 **in-lbs**), and install the bleeder cap.
9. If removed earlier, install one end of a length of clear plastic tubing over the **left-side** caliper bleeder valve, and place the free end in a suitable container. Add brake fluid to the master cylinder reservoir until the fluid level reaches the MAX marking inside the reservoir. Repeat Steps 5 through 8 for the left-side brake line.
10. Add brake fluid as needed to the master cylinder reservoir per the instructions in the Service Manual.

**NOTE**

*Before installing the master cylinder cover, verify that the cover gasket bellows is not expanded. If bellows is expanded, brake fluid is ejected from the reservoir during cover installation, which could damage the vehicle finish.*

11. Note that the shape of the master cylinder cover has one end thinner than the other. Install the cover (with gasket compressed) on the master cylinder reservoir so the thinner end is positioned above the brake line fitting. Install two Phillips-head screws to fasten the cover to the reservoir. Tighten the screws to 0.8–1.2 N·m (7–11 **in-lbs**).

**NOTE**

*The sight glass enables the rider to visually check the brake fluid level without removing the master cylinder cover. When the master cylinder is level and the reservoir is full, the sight glass is dark. As the fluid level drops, a bubble of air will start to appear in the glass to indicate this condition to the rider.*

12. Turn the Ignition/Light Key Switch to IGNITION, but do not start the motorcycle. Actuate the front brake hand lever to verify operation of the brake lamp.
13. Check the clutch lever for proper operation. If necessary, refer to CLUTCH ADJUSTMENT in the Service Manual.

14. **FLHRS/FLHRSE models:** Install the mirrors and front turn signals to the brake hand lever and clutch lever brackets. **All other models:** Install the mirrors to the brake hand lever and clutch lever brackets.

- a. Insert the threaded stem of the mirror into the hole in the brake lever or clutch lever bracket.
- b. Position the turn signal lamp bracket (if equipped) onto the mirror stem. Install the lockwasher and acorn nut onto the mirror stem threads, but do not fully tighten at this time.
- c. Repeat for the opposite-side lever bracket.
- d. Align the turn signal lamp housings so that the lenses will be aimed straight ahead for proper visibility. Align the mirrors for proper field of vision and compliance with local regulations.
- e. Tighten the acorn nuts to 16 N·m (12 ft-lbs).

**▲ WARNING**

**After repairing the brake system, test brakes at low speed. If brakes are not operating properly, testing at high speeds can cause loss of control, which could result in death or serious injury. (00289a)**

15. Test ride motorcycle at low speed. Repeat the bleeding procedure if brakes feel spongy.

## SERVICE PARTS

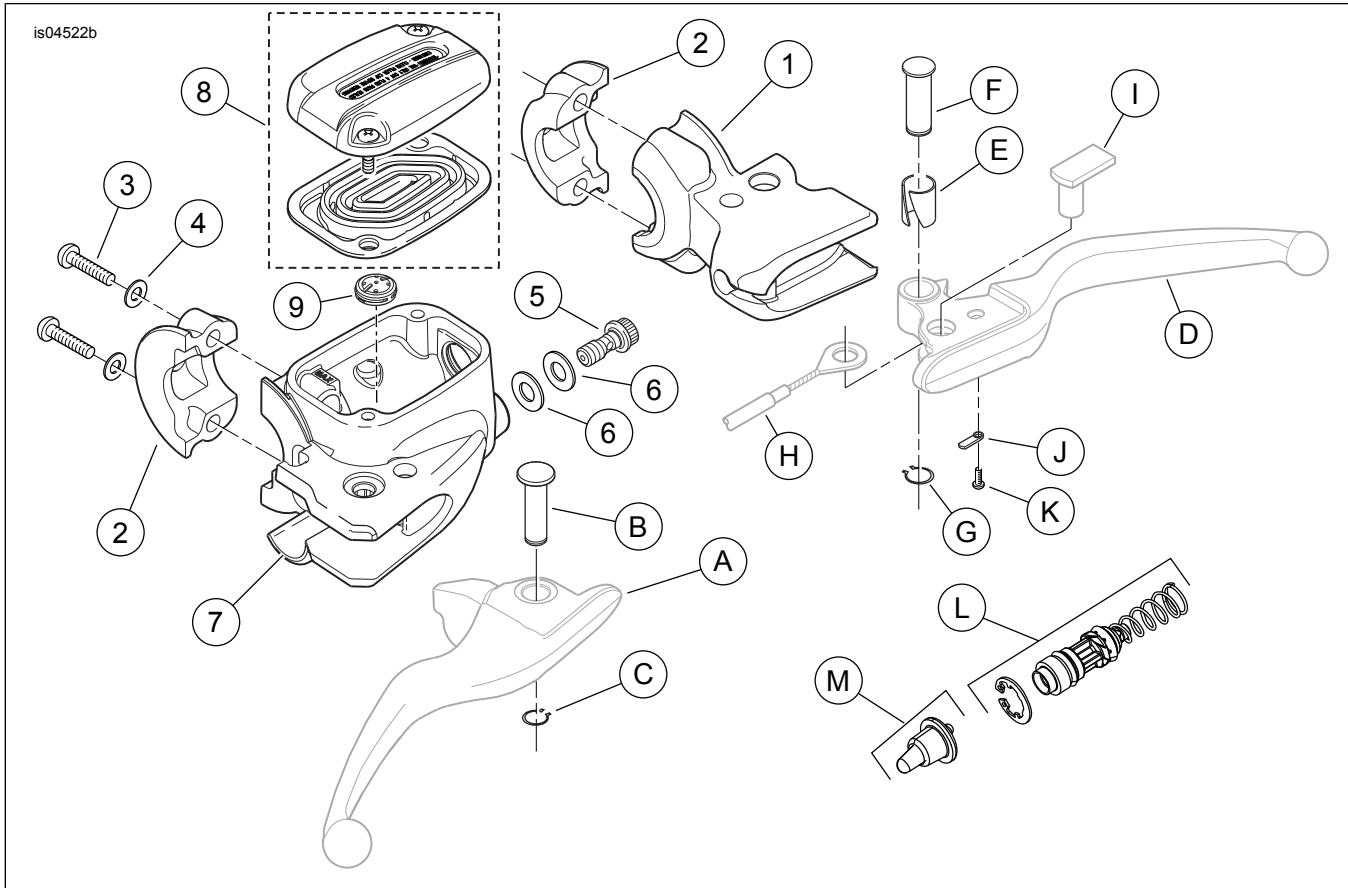

Figure 5. Service Parts, Chrome Clutch Bracket and Front Brake Master Cylinder Kit

## SERVICE PARTS

Table 1. Service Parts Table

Item	Description (Quantity)	Part Number
1	Bracket, clutch hand lever (chrome)	42104-08A
2	Clamp, brake/clutch lever bracket (chrome) (2)	42119-08
3	Screw, TORX® button head, 1/4-20 x 1-1/8 in. long (4)	4293
4	Flat washer (4)	6099
5	Banjo bolt (bright finish)	42010-06A
6	Copper gasket, brake line (2)	41751-06A
7	Brake master cylinder assembly, chrome (includes items 8 and 9)	42102-08D
8	• Cover kit, front brake master cylinder (chrome)	42123-08
9	• Anti-bubble button	41700367
<b>Items mentioned in text, but not included in kit:</b>		
A	Brake hand lever and pivot bushing	
B	Brake lever pivot pin	
C	Retaining ring	
D	Clutch hand lever	
E	Clutch lever pivot bushing	
F	Clutch lever pivot pin	
G	Retaining ring	
H	Clutch control cable	
I	Clutch cable anchor pin	
J	Anti-rattle spring	
K	Screw, anti-rattle spring	
<b>Additional replacement parts available:</b>		
L	Master cylinder repair kit	42862-06B
M	Pushrod kit	42861-06B