



INSTRUCTIONS

J04709

2008-02-15



XR1200 REAR CALIPER PAD KIT

GENERAL

Kit Number

42310-08

Models

For model fitment information, please see the P&A Retail Catalog or the Parts and Accessories section of www.harley-davidson.com (English only).

Additional Parts Required

Separate purchase and installation of additional parts or accessories may be required for proper installation of this kit on your model motorcycle. Please see the P&A Retail Catalog or the Parts and Accessories section of www.harley-davidson.com (English only) for a list of required parts or accessories for your model.

⚠ WARNING

Rider and passenger safety depend upon the correct installation of this kit. Use the appropriate service manual procedures. If the procedure is not within your capabilities or you do not have the correct tools, have a Harley-Davidson dealer perform the installation. Improper installation of this kit could result in death or serious injury. (00333b)

NOTE

This instruction sheet references Service Manual information. A Service Manual for your model motorcycle is required for this installation and is available from a Harley-Davidson Dealer.

⚠ WARNING

Always replace brake pads in complete sets for correct and safe brake operation. Improper brake operation could result in death or serious injury. (00111a)

NOTE

Replace brake pads if brake pad friction material on either the front or rear caliper is worn to 0.04 in. (1.02 mm) or less above the backing plates. Always replace both pads in a caliper as a set.

When checking the brake pads and discs, inspect the brake hoses for correct routing and any signs of damage or leakage.

Kit Contents

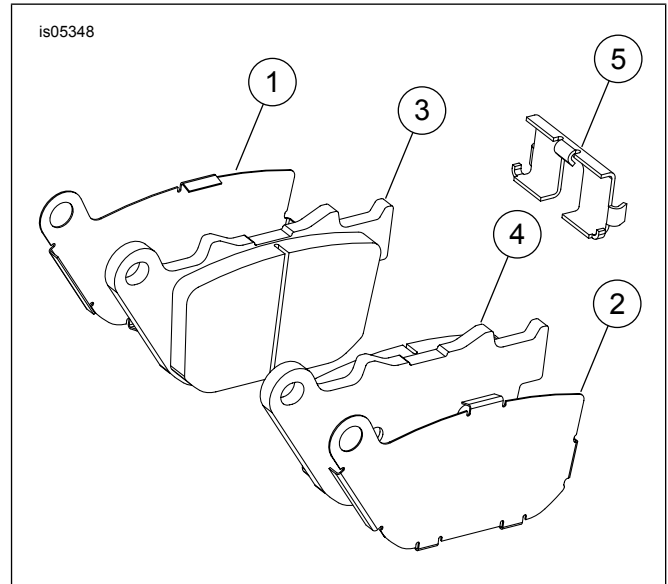

Figure 1. XR1200 Rear Caliper Pad Kit

Table 1. Kit Parts

Item	Description (Quantity)	Part Number
1	Retainer, A	Not Sold Separately
2	Retainer, B	Not Sold Separately
3	Brake pad, B	Not Sold Separately
4	Brake pad, A	Not Sold Separately
5	Retainer clip	Not Sold Separately

There are no Service Parts available with this kit.

INSTALLATION

1. Refer to "BRAKE PADS AND DISCS: XR MODELS" in the Service Manual to replace the brake pads.

