



INSTRUCTIONS

J04713

2009-07-21



XL FRONT END LOWERING KIT

GENERAL

Kit Number

45500-09

Models

For model fitment information, see the P&A Retail Catalog or the Parts and Accessories section of www.harley-davidson.com (English only).

Additional Parts Required

⚠ WARNING

This Front End Lowering Kit cannot be used independently. It must be used with an appropriate Low Rear Suspension Kit or handling and cornering can be affected, which could distract the rider, causing loss of control and death or serious injury. (00429b)

XL883, XL883R and XL1200R model motorcycles also require the separate purchase of a Rear Shock Kit (54754-09) which is available for purchase at your Harley-Davidson dealer.

Replacement 6 mm screw and copper washer (49378-09). Quantity of two required.

Installation of this kit also requires the following special tools: Fork Tube Holder (HD-41177), Fork Seal/Bushing Installation Tool (HD-36583), and Front Fork Oil Level Gauge (HD-59000B).

⚠ WARNING

Rider and passenger safety depend upon the correct installation of this kit. Use the appropriate service manual procedures. If the procedure is not within your capabilities or you do not have the correct tools, have a Harley-Davidson dealer perform the installation. Improper installation of this kit could result in death or serious injury. (00333b)

NOTE

This instruction sheet references service manual information. A service manual for your model motorcycle is required for this installation and is available from a Harley-Davidson Dealer.

Kit Contents

See Figure 8 and Table 1.

REMOVAL

Remove Right and Left Forks

1. Place suitable blocking under frame to raise front wheel several inches off the floor. For best results, use a hydraulic center stand on a level surface.

2. See the service manual and remove front wheel, fender and brake caliper.
3. Spray glass cleaner on the fork tube between upper and lower fork bracket to lubricate.

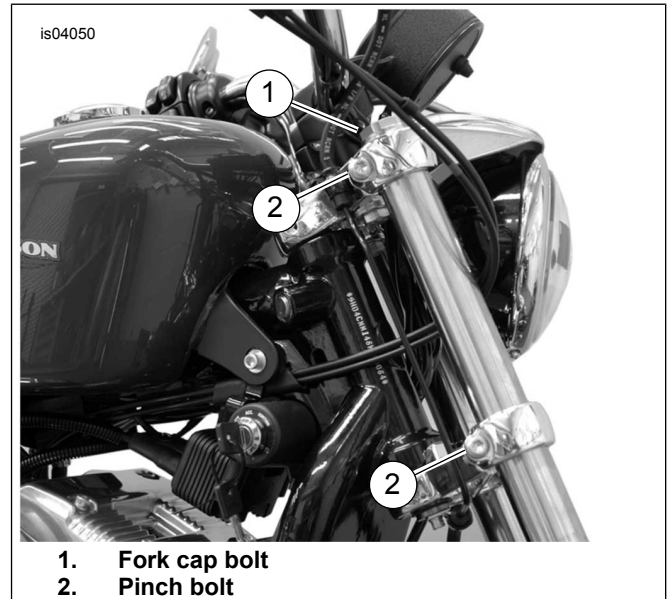

Figure 1. Loosen Pinch Bolt

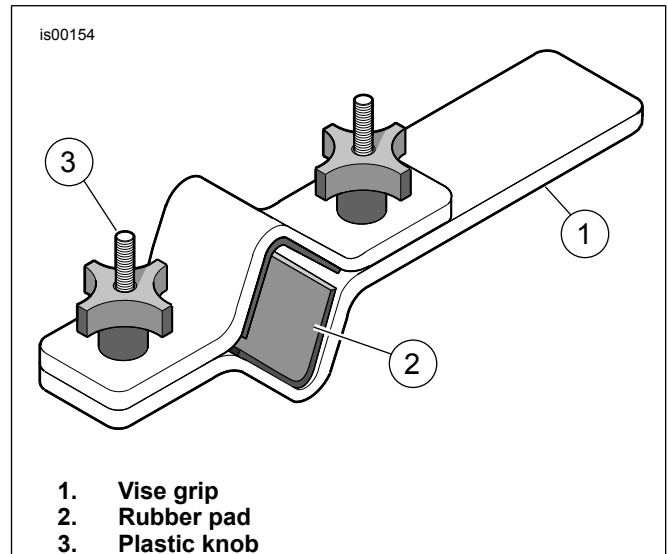

Figure 2. Fork Tube Holder (HD-41177)

4. See Figure 1. While holding the fork slider to prevent the fork from dropping, loosen pinch screws (2).
5. Remove fork tube by sliding the fork tube down and out of the upper and lower fork brackets.



6. Repeat Steps 3-5 to remove opposite fork.
7. Move forks to bench area. Place suitable drain pan on floor beneath vise.

Disassemble Left and Right Fork

▲ WARNING

Wear safety glasses or goggles when removing or installing spring. Spring tension can cause spring, attached components and/or hand tools to fly out which could result in death or serious injury. (00477c)

▲ WARNING

Wear safety glasses or goggles when servicing fork assembly. Do not remove slider tube caps without relieving spring preload or caps and springs can fly out, which could result in death or serious injury. (00297a)

1. See Figure 3. Obtain FORK TUBE HOLDER (Part Number HD-41177) and proceed as follows:
 - a. Clamp end of tool in vise in a horizontal position.
 - b. With the fork cap topside, clamp fork tube between rubber pads on inboard side of tool. Tighten knobs until fork tube is securely held.
2. See Figure 8. Place a drain pan under fork and remove drain screw (R).
3. See Figure 3. Carefully remove fork tube cap (1) and O-ring from fork tube. Be aware that fork tube plug is under spring pressure, so have a firm grasp on plug as the last thread is turned.
4. See Figure 8. Remove the spring washer (S) and spring collar (T) and save for reuse.
5. Remove the fork spring (1) from the fork tube.
6. Remove cover (G) and dust seal (H).
7. Compress internal circle clip (I). Remove clip from groove in top of slider bore.
8. Remove fork assembly from fork tube holder. Turn fork upside down and drain fork oil into drain pan. For best results, slowly pump fork tube and slider at least 10 times.
9. Install fork spring back into fork tube.
10. Put a shop rag on the floor. Turn the fork assembly upside down and press the end of the spring against the rag. Compress the spring and remove the 6 mm screw and washer (Q) from end of fork slider (N, O or P). Use air impact wrench for best results. Discard 6 mm screw (S) and copper crush washer (R).
11. Remove fork spring (1) and damper tube (2) from fork tube. Discard fork spring.
12. Withdraw slider tube (E) from slider (N, O or P) until lower bushing (F) on slider tube contacts upper bushing (L) in slider. Use lower bushing in a slide hammer motion to gently tap out oil seal, spacer and upper bushing from slider bore.
13. Remove lower stop (M). The lower stop is in the slider (N, O or P) or on the bottom end of the damper tube (2).
14. Insert a small diameter rod through the opening in the bottom of the slider tube to remove damper tube assembly.

15. Remove rebound spring (D) from damper tube (2). Discard damper tube.
16. See the service manual for front fork cleaning and inspection procedure. Replace parts as necessary.
17. Repeat Steps 1-16 for the opposite fork.

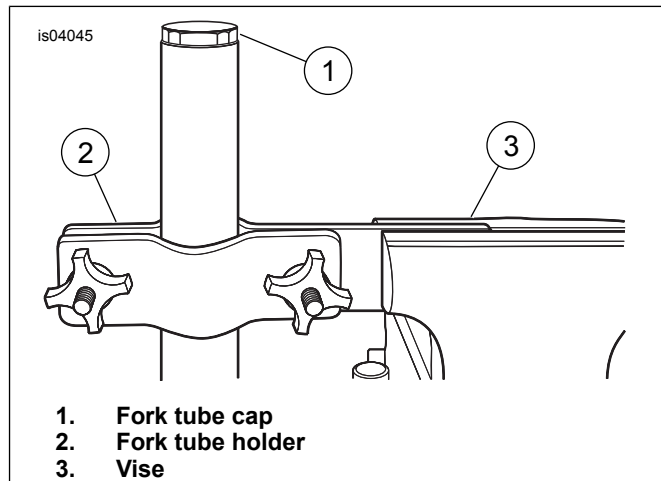

Figure 3. Install Fork Tube into Holder

INSTALLATION

Assemble Right and Left Fork

NOTICE

Exercise caution to avoid scratching or nicking fork tube. Damaging tube can result in fork oil leaks after assembly. (00421b)

1. See Figure 8. Install new lower bushing (F) in groove of slider tube (E). Expand bushing only wide enough to fit over the tube.
2. Place rebound spring (D) over damper tube. Verify that the damper tube ring (C) is installed in groove at top of new damper tube (2). Insert damper tube into slider tube (E).
3. Insert new spring (1) into slider tube (E) with the dense coil end down. Push damper tube (2) through opening at the bottom of the tube using the spring. Place the lower stop (M) over the end of the damper tube.
4. Install the slider tube assembly into the slider (N, O or P).
5. Install the screw and washer (Q) into the bottom of the slider (N, O or P). Move the slider tube through its full range of travel within the slider several times to verify proper component alignment. Then, applying downward force on the spring and tighten the screw. Tighten screw to 15–25 N·m (11–18 ft-lbs).
6. Place the upper bushing (L), spacer (K) (concave side down), oil seal (J) (lettering side up), and FORK SEAL AND BUSHING INSTALLATION TOOL (Part Number HD-36583) over slider.
7. See Figure 5. Install bushing, spacer and seal into slider bore by tapping components downward with the installation tool.

8. See Figure 8. Install internal circle clip (I) into groove in top of the slider bore.
9. Install dust seal (H) and cover (G) at the top of the slider.
10. Install drain screw (R) into the lower end of the slider. Tighten the screw to 8–11 N·m (72–96 **in-lbs**).
11. Remove main spring (1) from slider tube (E).
12. Pour 350 ml of Harley-Davidson Type E Fork Oil into fork tube.
13. Pump fork tube 10 times to remove air from system.



Figure 4. Fork Seal/Bushing Tool (HD-34634)

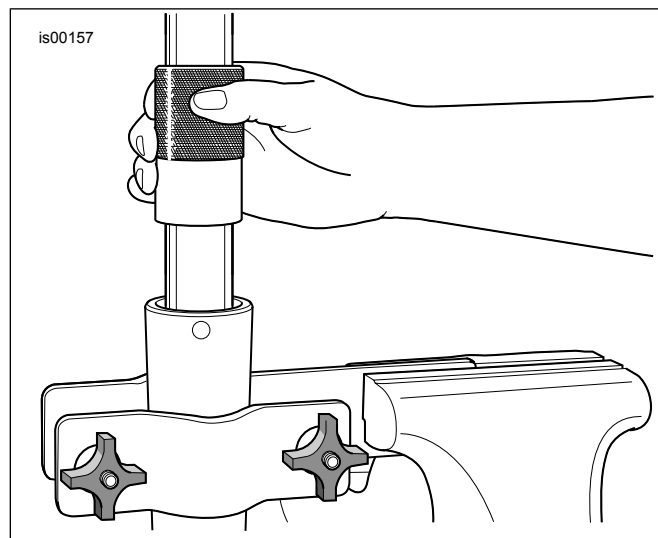

Figure 5. Install Fork Oil Seal

⚠ WARNING

Incorrect amount of fork oil can adversely affect handling and lead to loss of vehicle control, which could result in death or serious injury. (00298a)

14. See Figure 7. Adjust the fork oil level, so that it is 120 mm (4.72 in) from the top of the fork tube with the fork tube compressed and the main spring removed. Proceed as follows:
 - a. Loosen thumbscrew of FRONT FORK OIL LEVEL GAUGE (HD-59000B) on metal ring and move it up or down the rod until the bottom of the ring is 120 mm (4.72 in) from the bottom of the rod. Tighten thumbscrew.
 - b. Push the handle on the cylinder all the way in.
 - c. Insert rod into top of fork tube until metal ring rests flat on top of fork tube and the slider tube is pushed all the way into the slider.
 - d. Pull out handle to remove fork oil from fork tube. Observe fork oil through transparent tube as it is drawn into cylinder.
 - e. Remove rod from fork tube. Push handle into cylinder to eject excess fork oil into suitable container.
 - f. If necessary, repeat Steps 14(b)-14(e). Level is correct when no fork oil is observed being drawn through transparent tube.

15. Install main spring (1) into the slider tube (E) with the dense coil end down.

16. Install spring washer (S) and then spring collar (T) (from original fork).

17. Install slider tube cap (A) and O-ring (B) on top of slider tube. Tighten cap to 29.9–80 N·m (22–59 ft-lbs).

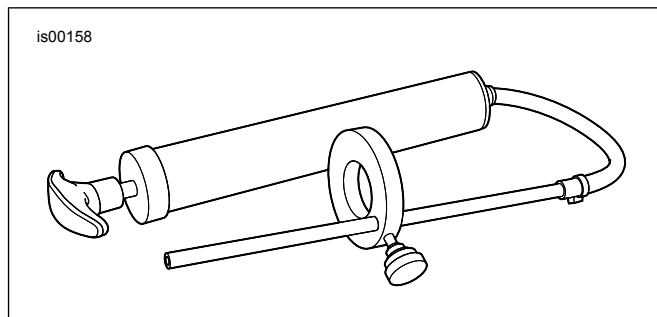

Figure 6. Front Fork Oil Level Gauge (HD-59000B)

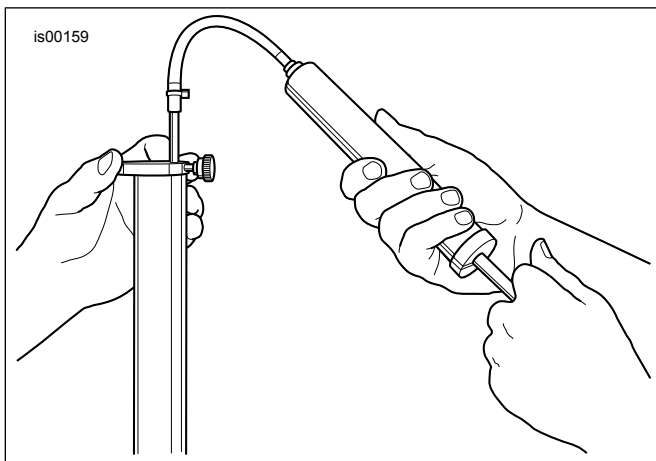

Figure 7. Remove Excess Fork Oil

18. Remove fork assembly from fork tube holder.
19. Repeat Steps 1-18 for the opposite fork assembly.

Install Front Forks

1. See Figure 1. Insert fork slider through the front lower and upper brackets. Position slider tubes so that the top of each tube cap (1) extends 10.7–12.7 mm (0.42–0.5 in) above top surface of front fork upper bracket.

2. On models with directional lamps mounted to the front fork bracket, hold directional lamp mounting brackets upright. On all models, tighten front fork upper and lower bracket pinch screws (2) to 40.7–47.5 N·m (30–35 ft-lbs).
3. Repeat Steps 1 and 2 for opposite fork.
4. See the service manual and install the front fender, wheel and brakes.

▲ WARNING

Whenever a wheel is installed and before moving the motorcycle, pump brakes to build brake system pressure. Insufficient pressure can adversely affect brake performance, which could result in death or serious injury. (00284a)

5. Pump brake hand lever to build system pressure.
6. Test ride the motorcycle to verify proper fork travel and rebound. If the brakes feel spongy, bleed the brake system again.

SERVICE PARTS

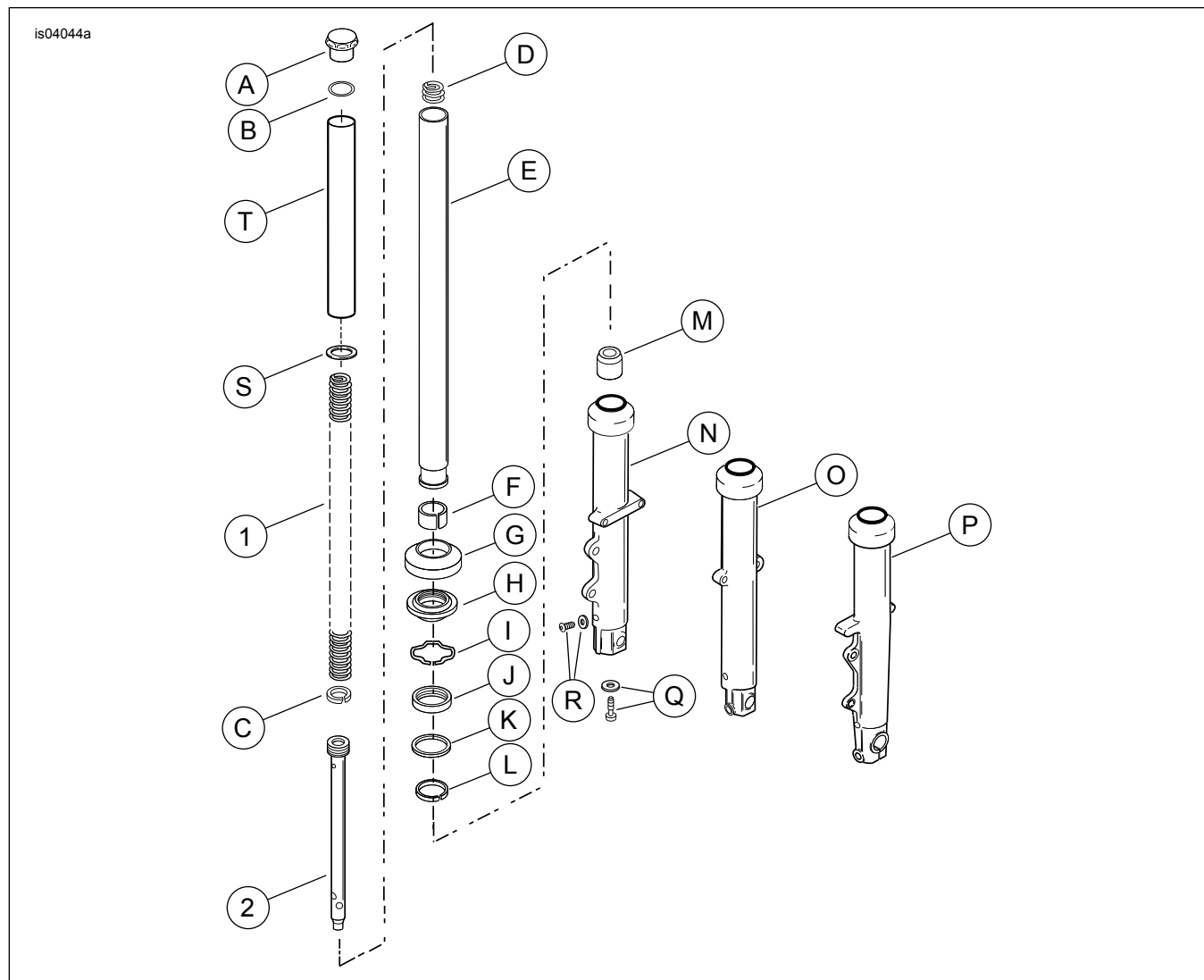

Figure 8. Service Parts for XL Front End Lowering Kit (45500-09)

Table 1. Service Parts Table

Item	Description (Quantity)	Part Number
1	Spring (2)	Not Sold Separately
2	Damper tube (2)	Not Sold Separately
Items mentioned in text, but not included in kit:		
A	Cap, slider tube (2)	
B	O-ring (2)	
C	Ring, damper tube (2)	
D	Spring, rebound (2)	
E	Slider tube with slider tube bushing (2)	
F	Bushing, lower (2)	
G	Cover, slider (2)	
H	Seal, dust (2)	
I	Circle clip (2)	
J	Oil seal (2)	
K	Spacer, oil seal (2)	
L	Bushing, upper (2)	
M	Lower stop (2)	
N	Slider assembly, left	
O	Slider assembly, right (all except XL883R/XL1200R)	
P	Slider assembly, right (XL883R/XL1200R)	
Q	Screw and washer (2)	
R	Drain screw with washer (2)	

Table 1. Service Parts Table

Item	Description (Quantity)	Part Number
S	Washer, spring (2)	
T	Collar, spring (2)	