



# INSTRUCTIONS

J04410

2011-07-20



## DYNA DETACHABLE SADDLEBAGS

### GENERAL

#### Kit Number

90181-08A

#### Models

For model fitment information, see the P&A Retail Catalog or the Parts and Accessories section of [www.harley-davidson.com](http://www.harley-davidson.com) (English only).

#### Additional Parts Required

Separate purchase of additional parts or accessories may be required for proper installation of this kit. See the P&A Retail Catalog or the Parts and Accessories section of [www.harley-davidson.com](http://www.harley-davidson.com) (English only) for a list of required parts or accessories for your model.

Separate purchase of Loctite® 243 Threadlocker and Sealant - Blue (99642-97) is required for proper installation of this kit. Loctite is available from a Harley-Davidson dealer.

#### ⚠ WARNING

Rider and passenger safety depend upon the correct installation of this kit. Use the appropriate service manual procedures. If the procedure is not within your capabilities or you do not have the correct tools, have a Harley-Davidson dealer perform the installation. Improper installation of this kit could result in death or serious injury. (00333b)

#### NOTE

This instruction sheet references service manual information. A service manual for your model motorcycle is required for this installation and is available from a Harley-Davidson Dealer.

### Kit Contents

See Figure 6 and Table 1.

#### ⚠ WARNING

Do not exceed saddlebag weight capacity. Put equal weight in each bag. Too much weight in saddlebags can cause loss of control, which could result in death or serious injury. (00383a)

#### NOTE

Maximum saddlebag weight capacity is 7 pounds (3.2 Kg).

#### ⚠ WARNING

Federal Motor Vehicle Safety Standard (FMVSS) 108 requires motorcycles to be equipped with rear and side reflectors. Be sure rear and side reflectors are properly mounted. Poor visibility of rider to other motorists can result in death or serious injury. (00336b)

### REMOVAL

1. Remove seat according to owner's manual instructions.

#### ⚠ WARNING

To prevent accidental vehicle start-up, which could cause death or serious injury, remove main fuse before proceeding. (00251b)

2. Remove the main fuse.
3. See Figure 6. Remove the shock absorber following the instructions in the left lower bracket kit (1) or right lower bracket kit (11).

### INSTALLATION

#### Fender Mounting Bracket Installation

##### Models with Detachable Rack or Sissy Bar

1. For all models except 2006-2008 FXDWG and FXDF models: Install turn signal relocation kit according to kit instructions.

#### NOTE

For 2006-2008 FXDWG and all FXDF models: Stock fender mounting bracket (Figure 1, item 2) can be reused or discarded and replaced with a new fender mounting bracket from the kit.

2. See Figure 1. Work on one side of the vehicle at a time. Remove two fender mounting screws (1) and fender mounting bracket (3). Discard screws.
3. Remove front docking point (4) and rear docking point (5). Save for later use.

#### NOTE

Recess cover (6) (if equipped) can be reused or discarded and replaced with a new recess cover from the kit.

4. Remove recess cover (6) (if equipped).
5. Place fender mounting bracket (3) inside fender so the threaded bosses fit inside the two holes in the fender.

#### NOTE

Apply Loctite 243 (blue) to last four threads of docking point screws.

6. See Figure 2. **Front Screw:** Install new mini docking point (1) and front docking point (6) onto new button head screw (2). Install screw through front hole of fender support (7) and into fender mounting bracket (3).
7. **Rear Screw:** Install mini docking point (1) and washer (4) onto button head screw (2) from the installation kit. Install rear docking point (8) (with flat side of docking point toward washer) and recess cover (5) (if equipped) onto screw. Install screw through the rear hole of the fender support (7) and into the fender mounting bracket (3).
8. Tighten both front and rear screws to 28–37 N·m (21–27 ft·lbs).
9. Repeat steps for the other side.

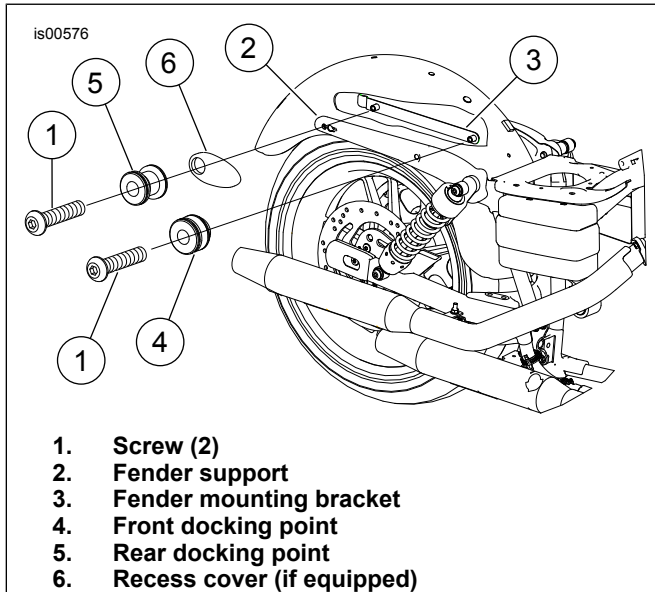

Figure 1. Models with Detachable Accessories

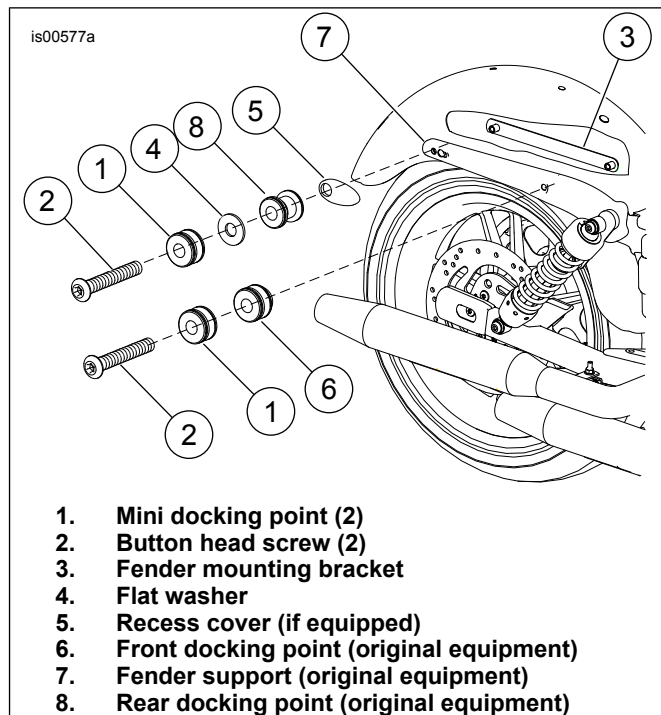

Figure 2. Install Fender Mounting Kit (Models with Detachable Accessories)

#### Models without Detachable Rack or Sissy Bar

1. **For all models:** See Figure 3. Work on one side of the vehicle at a time. Remove and discard stock fender mounting screws (1) and stock fender mounting bracket (2) from fender support (3).

#### NOTE

The rear hole on the stock fender mounting bracket is not threaded. Both holes on the bracket in the docking hardware kit are threaded.

2. See Figure 4. Place new fender mounting bracket (3) inside fender so the threaded bosses fit inside the two holes in the fender.

#### NOTE

Apply Loctite 243 (blue) to last four threads of docking point screws.

3. **Front Screw:** Install mini docking point (1) and front spacer (6) onto button head screw (2) from the installation kit. Install screw through the front hole of the fender support (8) and into the new fender mounting bracket (3).
4. **Rear Screw:** Install mini docking point (1) and washer (4) onto button head screw (2) from the installation kit. Install the new rear spacer (7) and the new recess cover (5) (if equipped) onto screw. Install screw through rear hole of the fender support (8) and into the new fender mounting bracket (3).
5. Tighten both front and rear screws to 28–37 N·m (21–27 ft·lbs).
6. Repeat steps for the other side.

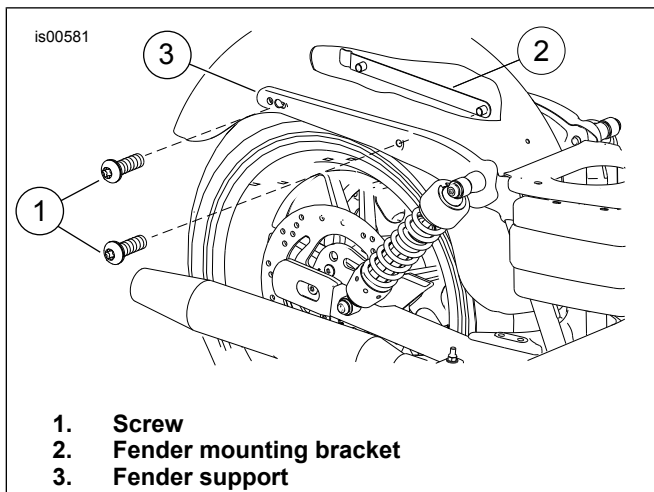

**Figure 3. Models without Detachable Accessories**

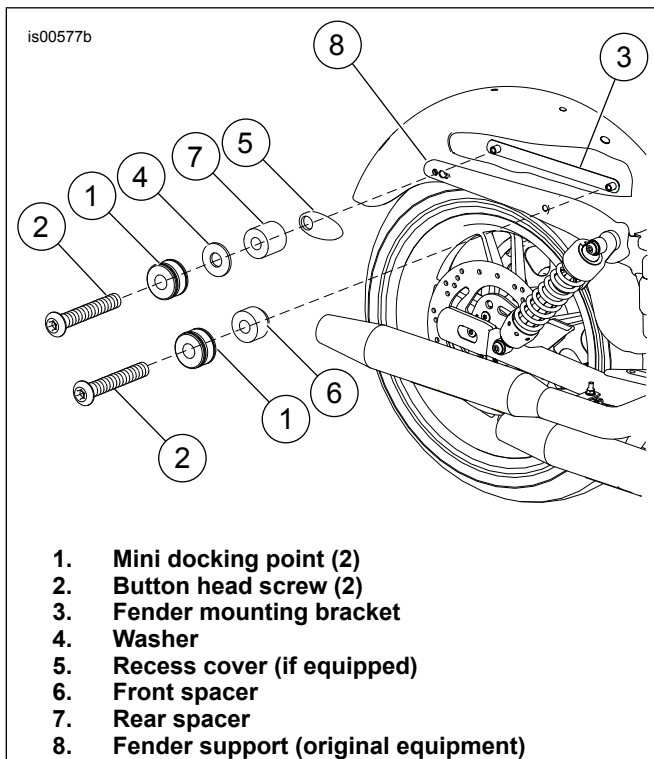
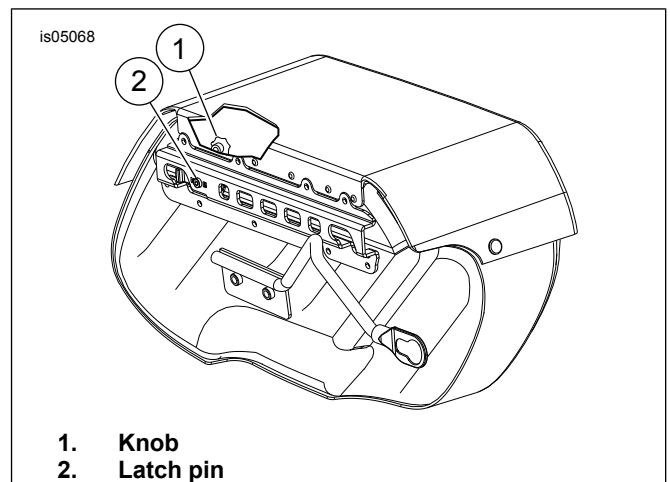

**Figure 4. Install Fender Mounting Kit (Models without Detachable Accessories)**

## Saddlebag Installation

1. See Figure 6. Install right lower support arm (13) and left lower support arm (9) following the instruction sheets included in those kits.
2. Open the saddlebag.
3. See Figure 5. From the inside of the saddlebag pull and rotate the knob (1) one-quarter turn and the latch pin (2) will release.
4. See Figure 6. Tip the bag forward and swing the large diameter of the keyhole end of the lower support arm (13) over the lower docking point (19). Swing the body of the bag down so that the outer docking points on the strut cover slide into the slots on the back of the bag.

5. Slide the bag forward making sure that it is fully seated onto all three docking points.
6. With the bag as far forward as possible, rotate the knob one-quarter turn. If the bag is seated properly, the knob should snap back in. Look behind the bag and make sure that the latch is in the closed position.
7. Rotate the bracket (5 or 12) so that the lower docking point is fully-seated into the smaller diameter of the lower support arm. Tighten the upper shock mounting bolt following the instructions in the service manual.
8. If adjusting the bracket in Step 7 causes the bag or lower support arm to be lifted or pushed down, loosen the two screws (7 or 8) holding the lower support arm to the saddlebag and adjust the lower support arm forward or back as needed.
9. Tighten the two support arm screws to 7–10 N·m (60–90 in-lbs).
10. Repeat all steps for the other side.



**Figure 5. Saddlebag Knob and Latch**

## Reflector Installation

### ⚠ WARNING

Federal Motor Vehicle Safety Standard (FMVSS) 108 requires motorcycles to be equipped with rear and side reflectors. Be sure rear and side reflectors are properly mounted. Poor visibility of rider to other motorists can result in death or serious injury. (00336b)

1. See Figure 6. Position reflector (21) in center of saddlebag between straps.
2. Mark holes on saddlebag with pen (or other appropriate tool).
3. Using soapy water or isopropyl alcohol, clean the surface of the reflector mount where reflector will be installed.
4. Allow the surface to dry completely before continuing.
5. Remove adhesive from back of reflector and install on reflector mount. Apply pressure to reflector for at least one minute.

- Using appropriate tool, make two 3/16 inch holes in saddlebag at locations marked in Step 2.
- Install reflector mount on saddlebag using two push nuts (22). The push nuts are installed from inside the saddlebag.
- Let the adhesive cure for at least 24 hours at no less than 60 °F (16 °C).
- Repeat for the other saddlebag.

## FINAL INSTALLATION

- Install the main fuse.

### ⚠ WARNING

**After installing seat, pull upward on seat to be sure it is locked in position. While riding, a loose seat can shift causing loss of control, which could result in death or serious injury. (00070b)**

- Install seat according to owner's manual instructions.

## Maintenance

### Docking Point Screws

#### NOTE

*After 500 miles (800 km) of on-road use with the saddlebags installed, confirm the torque is to specification as listed in the instructions for that kit. Tighten bolts again if necessary.*

## Saddlebag Docking Points

#### NOTE

*In time, the docking points may wear, adjust the wear surfaces of the docking points:*

- Loosen the docking hardware.
- Rotate the docking points clockwise approximately 90 degrees.
- Tighten the docking hardware to 28–37 N·m (21–27 ft-lbs).

This procedure can be completed one time before replacement of the docking points is required.

## Saddlebag Care

Apply the Leather Dressing included with the saddlebag kit according to the supplied directions.

#### NOTE

*Genuine Harley-Davidson Leather Dressing (98261-91V) is available for purchase from any Harley-Davidson dealer.*

# SERVICE PARTS

is05035c

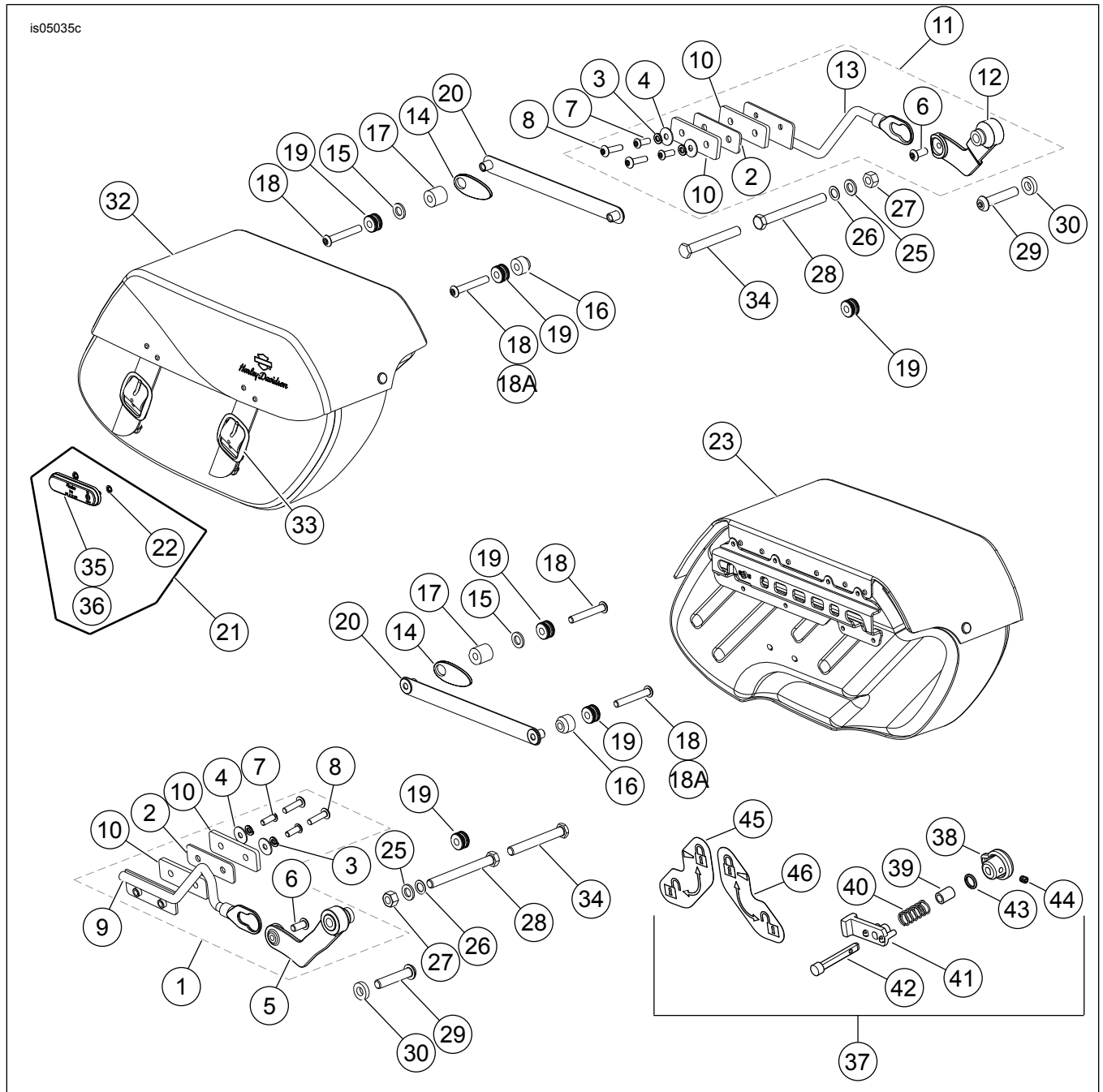

Figure 6. Service Parts: Dyna Detachable Saddlebag

Table 1. Service Parts: Dyna Detachable Saddlebags

Item	Description (Quantity)	Part Number
1	Lower Saddlebag Bracket Kit, Left (includes items 2-10)	90642-06C
2	Isolator, lower support arm (2)	Not Sold Separately
3	Lockwasher (4)	7041
4	Fender washer (4)	6788
5	Bracket, left	Not Sold Separately
6	Screw, button head TORX, 3/8-16 x 0.75 inch (2)	4097
7	Screw, button head, 5/16-18 x 0.875 inch (4)	4359
8	Screw, button head TORX, 5/16-18 x 1.375 inch (4)	4778
9	Lower support arm, left	Not Sold Separately
10	Spacer (4) (for FXDF, FXDFSE and 2010-Later FXDWG models only)	Not Sold Separately
11	Lower Saddlebag Bracket Kit, Right (includes items 2-4, 6-8, 10, 12-13)	90637-06B

**Table 1. Service Parts: Dyna Detachable Saddlebags**

<b>Item</b>	<b>Description (Quantity)</b>	<b>Part Number</b>
12	Bracket, right	Not Sold Separately
13	Lower support arm, right	Not Sold Separately
14	Cover, recess (2)	47531-06
15	Washer (2)	6139
16	Spacer, front (2)	11802
17	Spacer, rear (2)	11801
18	Screw, 3/8-16 x 2.25 inch (4)	4030
18A	Screw, 3/8-16 x 2.75 inch (2) (FXDWG and FXDF models only)	3166
19	Docking point, mini (6)	53967-06
20	Bracket, fender mounting (2)	60198-06
21	Reflector Kit (2) (includes item 22, 35 and 36)	59480-04A
22	Push nut (2)	8126A
23	Saddlebag assembly, Left (includes item 24)	90183-08
24	Buckle, with male disconnect (2) (not shown)	88295-07
25	Washer (2)	6792
26	Washer, thin (2)	6113
27	Nut, hex (2)	7880
28	Bolt, 1/2-13 x 4.75 inches (2)	4677
29	Screw, button head 1/2-13 x 2.5 inches (2)	4580
30	Spacer, lower shock (2)	92140-06
31	Leather Care Kit (not shown)	Not Sold Separately
32	Saddlebag Assembly, Right (includes item 33)	90182-08
33	Buckle, with male disconnect (2)	88295-07
34	Bolt, 1/2-13 x 4.0 inches (2)	54718-06A
35	Reflector	59270-10
36	Reflector mount	Not Sold Separately
37	Latch Spring Kit, includes 38-46	88257-07B
38	• Knob, Latch (2)	Not Sold Separately
39	• Spacer, Tube (2)	Not Sold Separately
40	• Spring, Compression (2)	Not Sold Separately
41	• Latch (2)	Not Sold Separately
42	• Pin (2)	Not Sold Separately
43	• O-ring (2)	11900007
44	• Set-screw, #10-24 x 1/4 in. (2)	10200139
45	• Label, lock/unlock, left	Not Sold Separately
46	• Label, lock/unlock, right	Not Sold Separately