



INSTRUCTIONS

J04308

2010-07-27



BILLET BRAKE LEVER KITS

GENERAL

Kit Numbers

42638-08A, 46883-09, 40091-10, 38131-10

Models

For model fitment information, see the P&A Retail Catalog or the Parts and Accessories section of www.harley-davidson.com (English only).

Additional Parts Required

Separate purchase of Wheel Bearing Grease (99856-92) is required for proper installation of this kit. See a Harley-Davidson dealer for more information.

Proper installation of this kit also requires installing a Brake Pedal Pad, sold separately. Refer to the appropriate Parts Catalog for a stock replacement rubber pad or see the P&A Retail Catalog for a selection of brake pedal pads.

⚠ WARNING

Rider and passenger safety depend upon the correct installation of this kit. Use the appropriate service manual procedures. If the procedure is not within your capabilities or you do not have the correct tools, have a Harley-Davidson dealer perform the installation. Improper installation of this kit could result in death or serious injury. (00333b)

NOTE

A service manual is available for your model motorcycle from a Harley-Davidson dealer.

Kit Contents

See Figure 1 and Table 1.

REMOVAL

1. See Figure 1 and Table 1. Remove the cotter pin and washer (A) from the master cylinder clevis pin. Discard the cotter pin.

NOTE

The clevis pin has a slight interference fit. It may be necessary to use pliers to pull the clevis pin from the push rod. Be careful not to damage mating parts.

2. Remove the clevis pin (B) from the brake rod. Save for installation. Thoroughly clean and examine parts for wear. Replace if necessary.
3. Remove the brake lever mounting nut and flat washer and discard. Remove and discard the outer O-ring (C).

4. Remove the brake lever by rotating counterclockwise and lifting the master cylinder clevis if necessary. Pull the lever from the shaft. Remove and discard the inner O-ring.
5. Thoroughly clean the lever mounting shaft of grease and dirt.

INSTALLATION

NOTE

This Billet-Style Brake Lever is equipped with self-lubricating bushings. However, on FLHT and FLTR models, apply a thin film of wheel bearing grease (99856-92), purchased separately, to the mounting shaft and bushings prior to installation.

1. See Figure 1 and Table 1. Insert new O-rings (3) on either side of the lever bushings. Install the new billet style brake lever (1) onto the shaft.
2. Align the holes in the lever and brake rod and insert the stock clevis pin (B).
3. Install the small saved flat washer onto the clevis pin and insert the new cotter pin (2).
4. Install the large flat washer (4) and locknut (5) from the kit. Tighten the locknut to 20–27 N·m (15–20 ft-lbs).
5. Install the brake pedal pad to the brake lever.

⚠ WARNING

After repairing the brake system, test brakes at low speed. If brakes are not operating properly, testing at high speeds can cause loss of control, which could result in death or serious injury. (00289a)

6. Check the brake lever for proper operation and clearance through its full travel.



SERVICE PARTS

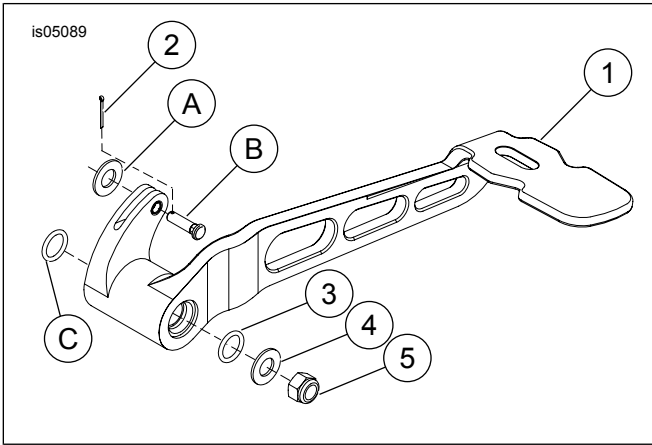

Figure 1. Service Parts: Billet Rear Brake Lever

Table 1. Service Parts

Item	Description (Quantity)	Part Number
1	Brake lever assembly	Not Sold Separately
2	Cotter pin	515
3	O-ring (2)	11364
4	Washer, 7/16 inch	6334
5	Locknut, 7/16 inch	7825
Items mentioned in text, but not included in kit.		
A	Washer	
B	Clevis pin	
C	Outer O-ring	