



# INSTRUCTIONS

J04411

2010-02-26



## SOFTAIL SEAT WITH RIDER BACKREST KIT

### GENERAL

#### Kit Number

51985-08, 51998-08, 51922-09, 54397-11

#### Models

For model fitment information, see the P&A Retail Catalog or the Parts and Accessories section of [www.harley-davidson.com](http://www.harley-davidson.com) (English only).

#### Kit Contents

See Figure 3 and Table 1.

#### Additional Parts Required

2006 FLSTFSE2 models require the separate purchase of Passenger Footpegs and Passenger Footpeg Mounting Kit (50749-05).

Some 2006 and earlier models require separate purchase of mounting bracket (51949-09). See the P&A Retail Catalog or a Harley-Davidson dealer.

### INSTALLATION

#### NOTE

*Cover painted surfaces with protective material to avoid damage.*

#### For FXST, FXSTS and FXSTB Models:

1. Remove existing seat from motorcycle by removing seat bolt at rear bracket and unhooking front seat tab.
2. See Figure 3. Remove and discard existing grab strap and save hardware.
3. Install the grab strap (11) from the kit to the accessory seat grab strap location with the screw (12) and washer (13).
4. **For Models that Require Separate Purchase of Mounting Bracket (51949-09):** Replace the rear seat bracket (15) with the rear seat bracket included with kit 51949-09 (F).

#### ▲ WARNING

**After installing seat, pull upward on seat to be sure it is locked in position. While riding, a loose seat can shift causing loss of control, which could result in death or serious injury. (00070b)**

5. Slide the back of the seat through grab strap and hook front tab of seat into frame. Secure seat bracket to fender with screw (C).

#### FXSTC Models:

#### NOTE

*Refer to the owner's or service manual instructions to remove the stock seat and mounting hardware.*

1. Remove and discard the existing grab strap and mounting hardware.
  2. Remove and discard the plug in the rear mounting position on the fender.
  3. See Figure 1. Using the retention nut (1), washer (2) and cable strap from the kit. Install the nut and washer in the rear hole location on the fender. A cable strap can be used as an installation aid.
  4. Place the retention nut (1) over the cable strap so that the wide end of the nut rests on the eye of the cable strap. Thread the cable up under the fender and through the rear most fender hole. Pull up on the cable strap to hold the nut snug against the underside of the fender.
  5. With the rib on the retention nut seated into the notch in the fender hole, slide the retention washer (2) into place from the rear (this will lock the retention nut in place) and then remove the cable strap.
  6. **For Kit 51985-08:** See Figure 3, item D. Install the grab strap (11) from the kit using a screw (12) and washer (13). **For Kits 51998-08 and 51922-09:** See Figure 3, item H. Install grabstrap (19) with screw (17), washer (18), spacer (20) and locknut (G).
  7. **For Models that Require Separate Purchase of Mounting Bracket (51949-09):** Replace the rear seat bracket (15) with the rear seat bracket included with kit 51949-09 (F).
- ▲ WARNING**
- After installing seat, pull upward on seat to be sure it is locked in position. While riding, a loose seat can shift causing loss of control, which could result in death or serious injury. (00070b)**
8. Slide the back of the seat through the grab strap and hook front tab of the seat into the frame. Secure the seat bracket to the fender with screw (C).



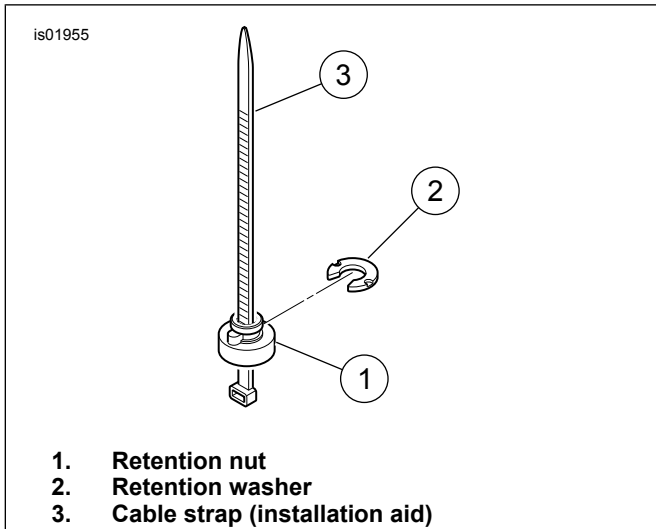

Figure 1. Retention Nut Installation

**FLST, FLSTC, FLSTSC, FLSTF, FLSTN and FLSTSB Models:**

*NOTE*

Refer to the owner's manual or service manual instructions for removal of the stock seat and mounting hardware.

**⚠ WARNING**

Do not install these seat kits on motorcycles that are not equipped with an appropriate grab strap and passenger footpegs. If footpegs and grab strap are not installed, passenger could fall from moving motorcycle or grab onto operator, causing loss of control and death or serious injury. (00410b)

1. Remove and discard the existing grab strap, if installed, and mounting hardware. (Save seat mounting nuts on FLSTN models.)
2. **For Kits 51998-08 and 51922-09:** See Figure 3, item H. Install grabstrap (19) with screw (17), washer (18), spacer (20) and locknut (G). **For Kit 54397-11:** See Figure 3, item J. Install ends of grabstrap (11) through stud plate (B). Secure grabstrap with seat mounting nuts (K). **For Kit 51985-08:** See Figure 3, item E. Install ends of grabstrap (11) through stud plate (B). Secure grabstrap with nut (14).

3. **For Models that Require Separate Purchase of Mounting Bracket (51949-09):** Replace the rear seat bracket (15) with the rear seat bracket included with kit 51949-09 (F).

**⚠ WARNING**

After installing seat, pull upward on seat to be sure it is locked in position. While riding, a loose seat can shift causing loss of control, which could result in death or serious injury. (00070b)

4. Slide the back of the seat through the grab strap and hook front tab of the seat (10) into the slot at the rear of the fuel tank and into the frame. Secure the seat bracket to the fender with screw (C).

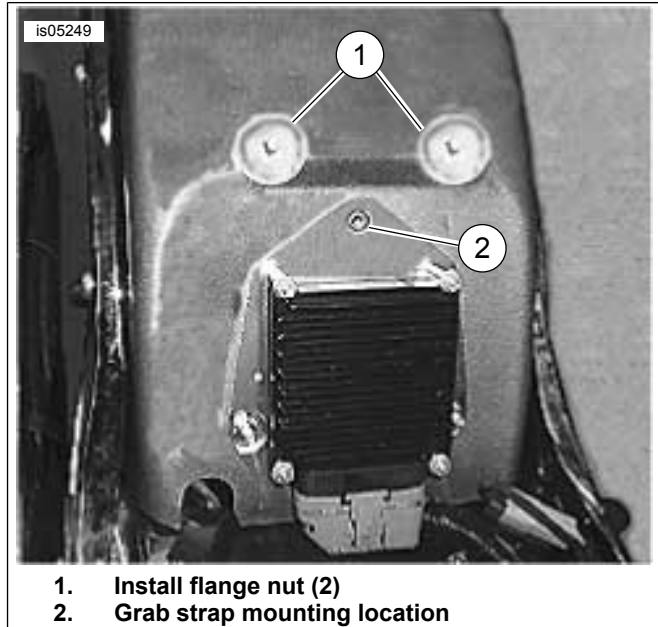

Figure 2. Grab Strap and Flange Nut Installation (FLSTF)

# SERVICE PARTS

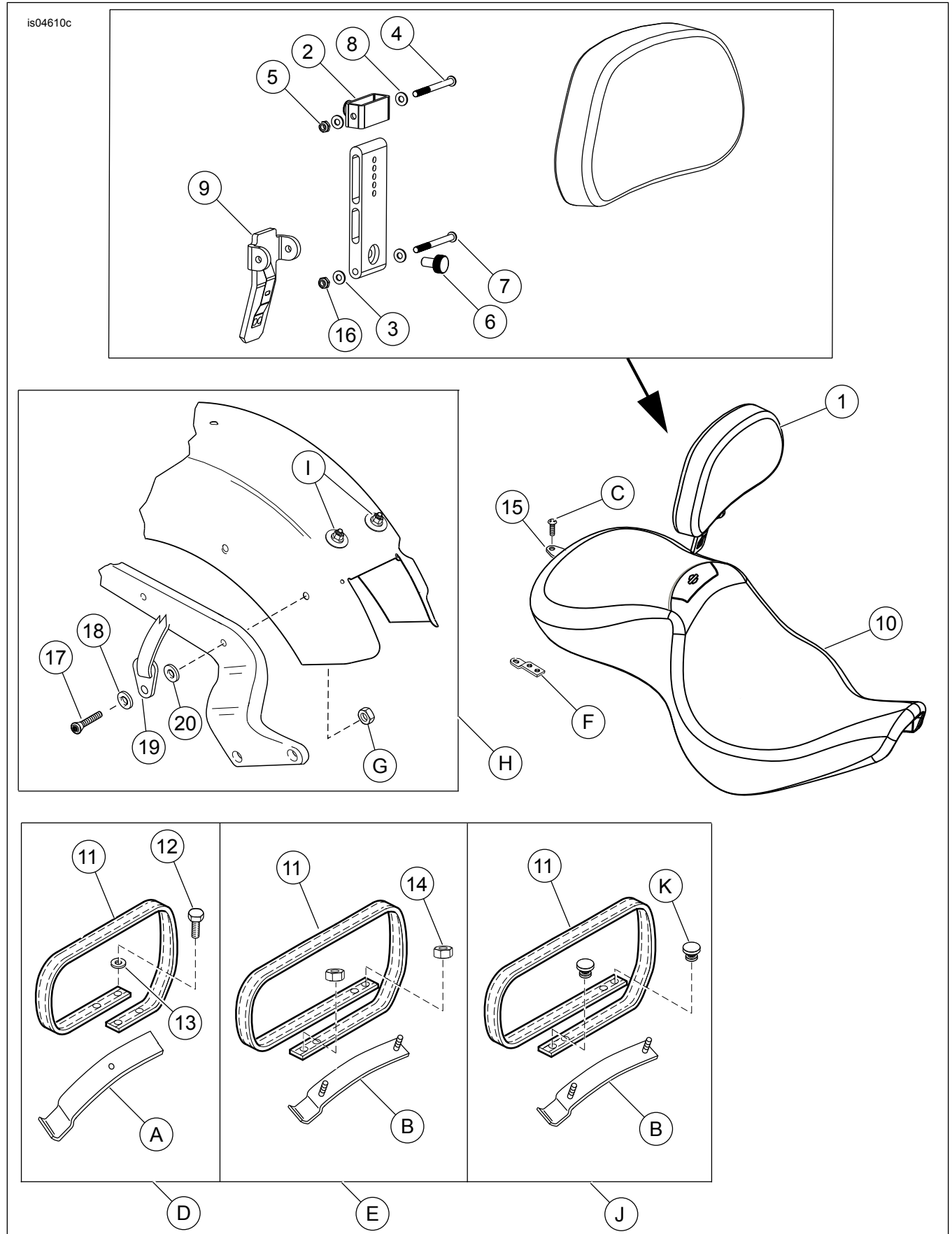

Figure 3. Service Parts: Softail Seat with Rider Backrest

**Table 1. Service Parts: Softail Seat with Rider Backrest**

<b>Item</b>	<b>Description (Quantity)</b>	<b>Part Number</b>
1	<b>Kits 51985-08 and 51998-08</b> Backrest assembly (includes Items 2-9)	51991-08A
1	<b>Kits 51922-09</b> Backrest assembly (includes Items 2-9)	51942-09
1	<b>Kit 54397-11</b> Backrest assembly (includes Items 2-9)	54398-11
2	Extrusion, slider rider backrest	52188-08
<b>Hardware kit (includes items 3-5, 7, 8 and 16)</b>		51666-06
3	Washer, non-metallic (2)	6410
4	Screw, button head (1)	4928
5	Locknut, black, thin	Not Sold Separately
6	Knob, adjustment backrest	51868-06A
7	Screw, hex head	Not Sold Separately
8	Washer, non-metallic	Not Sold Separately
9	Main pivot, rider backrest	Not Sold Separately
10	Seat	Not Sold Separately
11	Grab strap (Kits 51985-08 and 54397-11)	51188-86
12	Screw	3767B
13	Washer	6036
14	Flange nut (2) (not included in kit 54397-11)	8021
15	Seat mount bracket	51652-97
16	Locknut, black, thick	Not Sold Separately
17	Screw	4180
18	Washer	6379W
19	Grabstrap (Kits 51998-08 and 51922-09)	51224-09
20	Spacer	6019
<b>Items referenced in instruction sheet, but not included in kit:</b>		
A	Stud plate, one post	
B	Stud plate, two post	
C	Bolt, seat mounting	
D	FX Models - Kit 51985-08	
E	FL Models (except FLSTFSE2) - Kit 51985-08	
F	Seat mounting bracket (for some 2006-earlier models - purchase separately)	
G	Stock locknut on 2000-later models	
H	For Kits 51998-08 and 51922-09	
I	Stock locknut (if equipped)	
J	For Kit 54397-11 (FLSTN models)	
K	Seat mounting nut (FLSTN models)	