



INSTRUCTIONS

J04716

2011-11-08



SPORTSTER ALUMINUM SHIFT LINKAGE KITS

GENERAL

Kit Number

Table 1. Kit Contents

Kit Number	Style
34586-09	Slotted
37840-09	Skull
33778-09	Black slotted
33930-09	Diamond black
33900102	Silencer

Models

For model fitment information, see the P&A Retail Catalog or the Parts and Accessories section of www.harley-davidson.com (English only).

⚠ WARNING

Rider and passenger safety depend upon the correct installation of this kit. Use the appropriate service manual procedures. If the procedure is not within your capabilities or you do not have the correct tools, have a Harley-Davidson dealer perform the installation. Improper installation of this kit could result in death or serious injury. (00333b)

Kit Contents

See Figure 2 and Table 2.

INSTALLATION

1. See Figure 1. Remove stock capscrews (4) and stock shifter rod (2). Discard stock capscrews.
2. See Figure 2 and Table 2. Loosen the lock nuts (5) and turn the rod ends on the new aluminum shifter rod (1) to match the length of the stock shifter rod.
3. See Figure 2 and Table 2. Slide longer capscrew (3) through the front rod end of new shifter rod (1). Place rod on the outside of the lever assembly. Thread capscrew (3) into the lever assembly.

4. Slide shorter capscrew (2) through the rear rod end of new shifter rod (1). Place rod on the outside of the transmission shift lever. Thread capscrew (2) into the transmission shift lever.
5. Tighten capscrews to 13.6–20.3 N·m (10–15 ft-lbs).
6. Firmly tighten the lock nuts (5) against the rod ends to 27.1–32.5 N·m (20–24 ft-lbs).

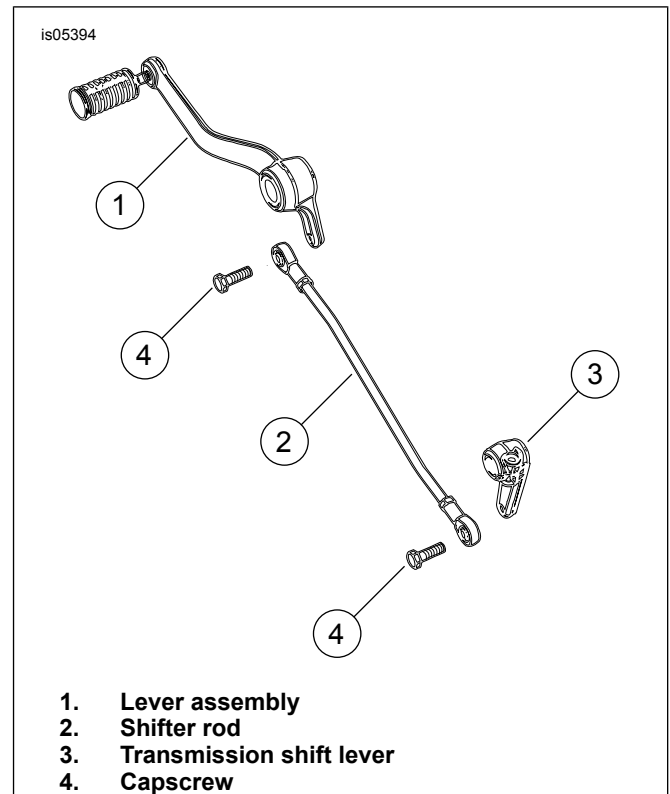

Figure 1. Shift Linkage Components

SERVICE PARTS

is05393

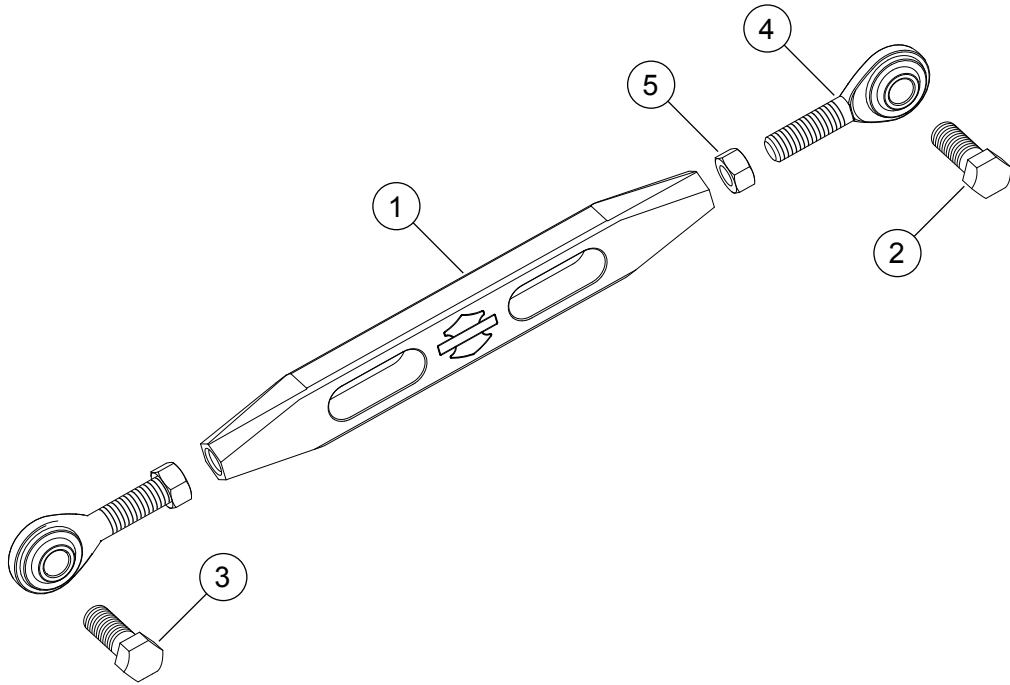

Figure 2. Service Parts: Sportster Aluminum Shift Linkage Kits (Slotted Linkage Shown)

Table 2. Service Parts Table

Item	Description (Quantity)	Part Number
1	Shifter rod linkage	Not Sold Separately
2	Capscrew with Loc-patch® 5/16-18 x 7/8 inch	4111
3	Capscrew with Loc-patch® 5/16-18 x 1.0 inch	4112
4	Rod ends (2)	33899-08
5	Lock nuts (2)	7326