



# INSTRUCTIONS

J04416

2007-03-07



## CHROME FRONT WHEEL SPACER KIT

### GENERAL

#### Kit Number

41371-08

#### Models

For model fitment information, please see the P&A Retail Catalog or the Parts and Accessories section of [www.harley-davidson.com](http://www.harley-davidson.com) (English only).

#### Additional Parts Required

##### ⚠ WARNING

Rider and passenger safety depend upon the correct installation of this kit. Use the appropriate service manual procedures. If the procedure is not within your capabilities or you do not have the correct tools, have a Harley-Davidson dealer perform the installation. Improper installation of this kit could result in death or serious injury. (00333b)

Permatex® Anti-seize Lubricant, Harley-Davidson Part Number 98960-97, is available from a Harley-Davidson Dealer.

#### Kit Contents

See Figure 4 and Table 1

### REMOVAL

1. Block motorcycle underneath frame so front wheel is raised off ground.
2. Use shop rag or tape to protect fender area adjacent to caliper, as contact can occur during caliper removal.
3. See Figure 1. Turn handlebars all the way to the right. From left side follow the ABS sensor wire (1) from brake caliper to fairing and disconnect it.
4. Remove both upper and lower mounting bolts (2) from lugs of left front fork leg to release brake caliper assembly, sensor wire bracket (D) and clip (E) (see Figure 4).
5. Lift caliper upward to remove from brake disc. Allow caliper to hang loose.
6. Repeat Steps 2 through 5 to remove opposite caliper.

#### NOTE

*Do not operate front brake lever with front wheel removed or the caliper piston(s) may be forced out of the piston bore(s). Re-seating piston(s) requires disassembly of the caliper.*

7. See Figure 4 and Table 1. Insert screwdriver or steel rod through hole in axle on right side of vehicle. While holding axle stationary, remove axle nut (F) and flat washer (G) on left side.
8. Loosen two axle holder nuts (J) at bottom of right side fork leg.

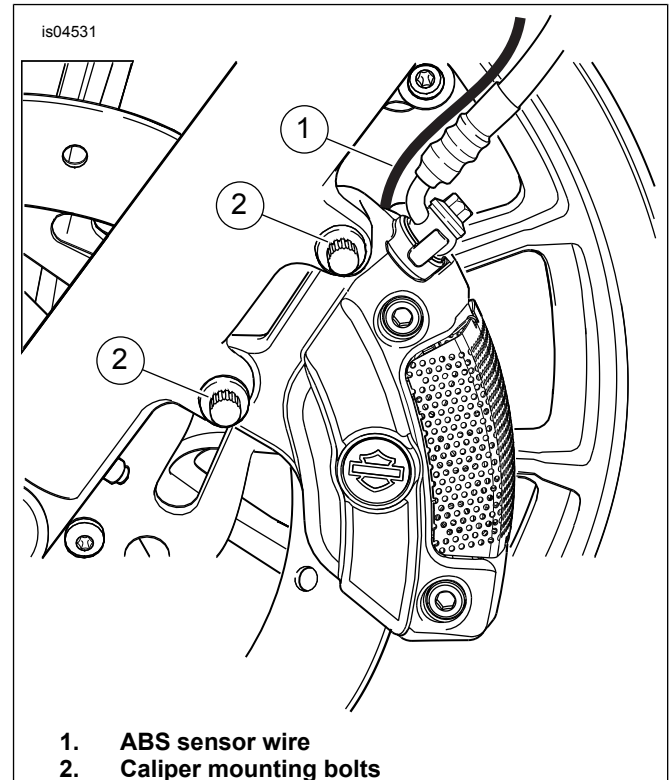

1. ABS sensor wire
2. Caliper mounting bolts

Figure 1. Caliper and Mounting Bolts

9. With a soft mallet, tap axle (I) toward right side of vehicle until loose. Pull axle just far enough to release ABS sensor (H) on left side and stock wheel spacer on right.
10. Discard stock right wheel spacer and save ABS wheel sensor.

### INSTALLATION

1. See Figure 2. Position ABS sensor cover (1) on sensor with slot lined up to wire connection. Place a block of wood on cover and with a soft mallet, tap cover onto sensor until sensor cover is flush (2) with sensor or seated with slight protrusion (3) of sensor.
2. Place wheel into position between forks with valve stem on right side of vehicle.



3. Apply a light coat of Permatex<sup>®</sup> Anti-seize Lubricant to axle (I).
4. Supporting wheel, insert threaded end of axle through right fork leg. Push axle through fork, new mushroom external spacer (2) and wheel hub until it begins to emerge from left side.

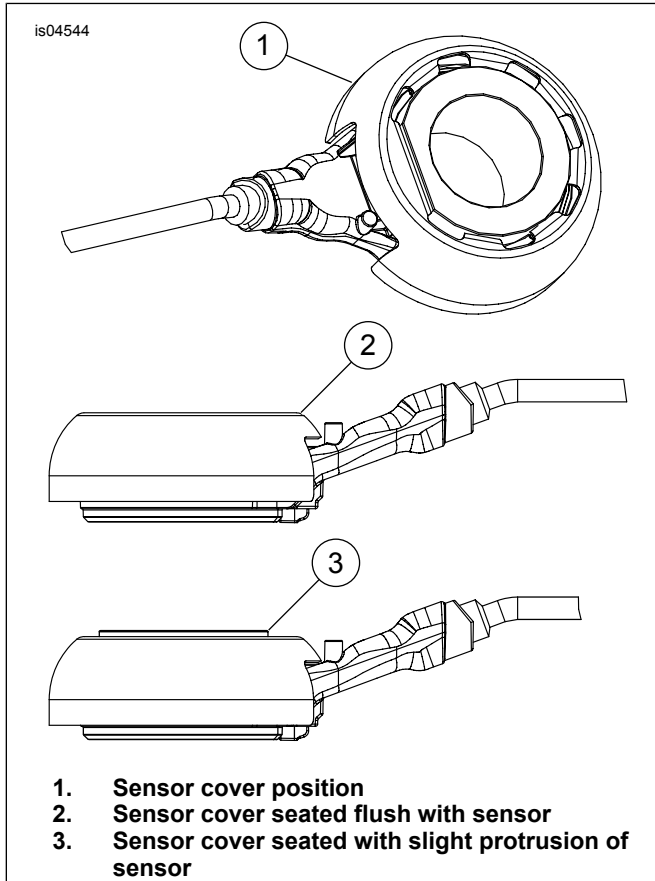

Figure 2. ABS Sensor Cover

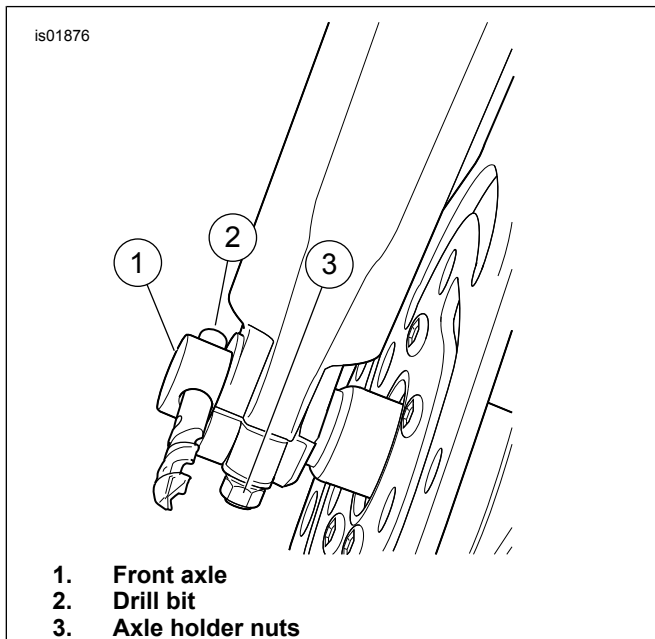

Figure 3. Front Wheel Mounting (Right Side)

5. Push axle through ABS sensor (H) and left fork leg until axle shoulder contacts sensor on right fork side.
6. Install flat washer (G) and axle nut (F).
7. Insert screwdriver or steel rod through hole in axle on right side of vehicle. While holding axle stationary, tighten axle nut to 68–75 N·m (50–55 ft-lbs).
8. See Figure 3. Insert 7/16 inch drill bit (2) into hole in axle (1).
9. Pull fork leg so that it just contacts drill bit, and then tighten axle holder nuts (3) to 14.9–20.3 N·m (132–180 in-lbs).
10. Remove drill bit from axle hole.
11. Install brake caliper as follows:
  - a. Use shop rag or tape to protect fender area adjacent to caliper, as contact can occur during caliper installation.
  - b. With bleeder valve topside, position caliper so that brake disc is situated between friction pads. Pry inner and outer brake pads back for additional clearance, if necessary.
  - c. Align caliper to mounting holes. For left side also align sensor wire bracket and clip. Insert bolts into lugs of fork leg. Tighten mounting bolts to 38–51.5 N·m (28–38 ft-lbs).
  - d. Repeat Step 11 to install caliper on opposite side of wheel.
12. Attach ABS sensor lead wire to fork clip and reconnect to fairing connector.

**⚠ WARNING**

Whenever a wheel is installed and before moving the motorcycle, pump brakes to build brake system pressure. Insufficient pressure can adversely affect brake performance, which could result in death or serious injury. (00284a)

13. Depress front brake hand lever several times to set brake pads to proper operating position within caliper.

# SERVICE PARTS

is04532

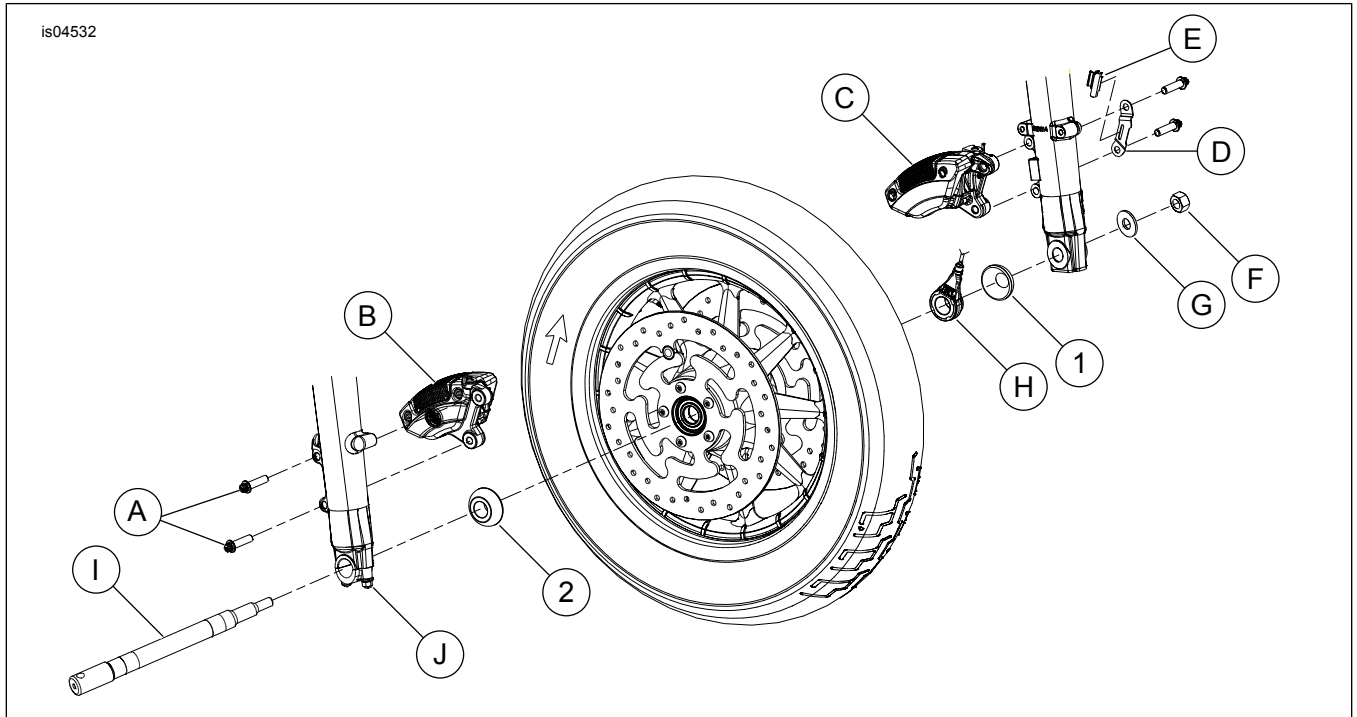

Figure 4. Service Parts: Chrome Front Wheel Spacer Kit

Table 1. Service Parts Table

Item	Description (Quantity)	Part Number
1	Cover, ABS sensor	40786-08
2	Spacer, front wheel, right side	44583-08
<b>Items mentioned in text, but not included in kit:</b>		
A	Bolts, caliper (4)	
B	Caliper, right	
C	Caliper, left	
D	Bracket, sensor wire	
E	Clip, sensor wire	
F	Nut, axle	
G	Washer, axle	
H	Sensor, ABS	
I	Axle	
J	Nut, axle retainer (2)	