



# INSTRUCTIONS

J04325

2008-07-14



## DERBY COVER

### GENERAL

#### Kit Number

25561-08, 25562-09

#### Models

For model fitment information, see the P&A Retail Catalog or the Parts and Accessories section of [www.harley-davidson.com](http://www.harley-davidson.com) (English only).

#### Additional Parts Required

Installation on 2006 and later Dyna and 2007 and later Softail and Touring models requires separate purchase of gasket (25416-99C).

Separate purchase of LOCTITE® 243 Threadlocker and Sealant (Blue) (99642-97) is required for proper installation of this kit. LOCTITE can be purchased from any Harley-Davidson Dealer.

#### Kit Contents

There are no Service Parts available for this kit.

### INSTALLATION

#### ⚠ WARNING

**Perform this installation when the engine is cool. Working on or near the exhaust system when the engine is hot could result in severe burns. (00311b)**

#### NOTE

*Remove clutch inspection (derby) cover with motorcycle upright, not on jiffy stand. If cover is removed with motorcycle on side stand, primary fluid will leak out of primary chaincase.*

1. Remove the **left-side** passenger footboard, if equipped.
2. Remove the five screws with captive washers. Save screws and washers for installation.

#### NOTE

*The gasket between the derby cover and the chaincase cover must be removed and all oil must be wiped from the gasket and groove in chaincase cover each time the cover is removed.*

3. Remove the gasket from the groove in the chaincase cover and mounting surface.
4. Inspect gasket for tears or damage. Replace as required.

#### NOTE

*If installing the derby cover on 2006 and later Dyna or a 2007 and later Touring or Softail model, the original*

*equipment gasket **must** be discarded and replaced with derby cover gasket (sold separately).*

*To avoid punching holes in the clutch inspection cover gasket or enlarging the existing holes, install the new derby cover and gasket as follows:*

5. Align the triangular shaped hole in the gasket with the top hole in the derby cover. Be sure the rubber molding and the words "towards clutch" face the motorcycle.
6. Place a washer onto the threads of one of the screws. Apply a few drops of Loctite 243 to threads the screw. Insert the screw into the top hole (position 1 in Figure 1 ) in the derby cover and carefully install it all the way through the triangular shaped hole in the gasket. Do not push the screw through the hole.
7. Repeat for the remaining four screws and washers.
8. Tighten screws to 10–12 N·m (84–108 **in-lbs**) in the sequence shown in Figure 1.

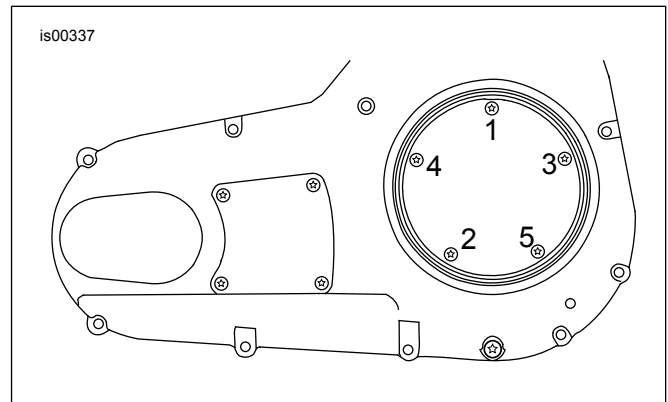

**Figure 1. Torque Sequence, Clutch Inspection Cover**

