



INSTRUCTIONS

J04718

2008-03-18



LOW REAR SHOCK KIT

GENERAL

Kit Number

54754-09

Models

For model fitment information, please see the P&A Retail Catalog or the Parts and Accessories section of www.harley-davidson.com (English only).

Additional Parts Required

This kit requires LOCTITE® 243 (blue) for proper installation.

⚠ WARNING

Rider and passenger safety depend upon the correct installation of this kit. Use the appropriate service manual procedures. If the procedure is not within your capabilities or you do not have the correct tools, have a Harley-Davidson dealer perform the installation. Improper installation of this kit could result in death or serious injury. (00333b)

NOTE

This instruction sheet references Service Manual information. A Service Manual for your model motorcycle is required for this installation and is available from a Harley-Davidson Dealer.

Kit Contents

See Figure 3 and Table 1.

INSTALLATION

Shock Absorbers

⚠ WARNING

Perform this installation when the engine is cool. Working on or near the exhaust system when the engine is hot could result in severe burns. (00311b)

⚠ WARNING

Installation of any accessory suspension components can affect cornering clearance. This could distract the rider, causing loss of control and death or serious injury. (00431b)

NOTE

This procedure requires that both shocks be removed prior to installing the new shock absorbers. You need to place the motorcycle on a center stand with the rear wheel raised off of the ground. The jiffy stand should be able to move through its full range of travel.

The exhaust system may interfere when removing and installing the lower right shock mounting hardware. If necessary, see Service Manual and remove the rear exhaust pipe.

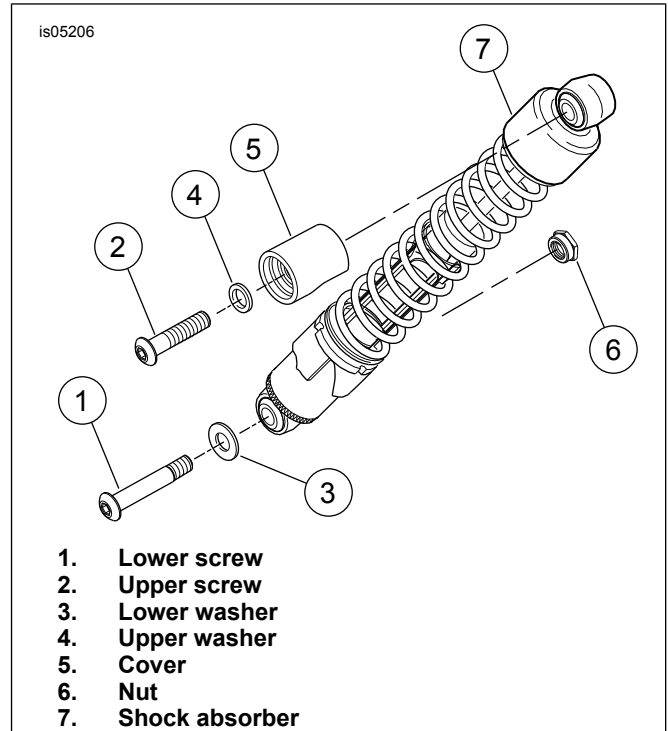

Figure 1. Remove / Install Shock Absorber

1. Block the motorcycle under the frame so that the motorcycle is securely resting upright, the jiffy stand may be moved through its full range of travel, and rear wheel is just off the ground.
2. Remove the lower shock mounting screw (1), washer (3) and nut (6) from the shock absorber (7). Save the hardware for reuse.
3. Remove the upper bolt (2), washer (4) and cover (5) and remove the shock absorber. Save the hardware for reuse.
4. Repeat Steps 1 and 2 for opposite side and save the hardware.
5. Apply 2-3 drops of LOCTITE 243® (blue) on the threads of the lower mounting bolt, then install bolt, lower washer and nut to the shock.
6. Apply 2-3 drops of LOCTITE 243® (blue) on the threads of the upper mounting bolt, then install the shock cover, upper mounting bolt and washer to the shock. Verify the cutout in shock cover locates properly.



NOTE

Verify that the shock covers stay centered on the shock and do not turn when tightening the shock mounting bolts.

7. Tighten mounting bolts to 61.1–67.9 N·m (45–50 ft-lbs).
8. Repeat Steps 4, 5 and 6 for the opposite side.

NOTE

Spanner wrenches are available to adjust the shock spring preload, Part Number HD-94700-52C or HD-94820-75A. These tools can be purchased from your Harley-Davidson Dealer.

▲ WARNING

Adjust both shock absorbers equally. Improper adjustment can adversely affect stability and handling, which could result in death or serious injury. (00036b)

NOTICE

Wipe all fingerprints off of exhaust system components after installation and before starting engine. Oil from hands can leave permanent marks on exhaust system finish. (00346a)

9. See the Service Manual and install rear exhaust pipe, if removed.

Jiffy Stand

▲ WARNING

Wear safety glasses or goggles when removing or installing spring. Spring tension can cause spring, attached components and/or hand tools to fly out which could result in death or serious injury. (00477c)

1. Remove the rubber bumper from the frame to permit further retraction of the jiffy stand leg. Additional spring tension relief allows for easier spring removal.
2. See Figure 2. Place the jiffy stand leg in retracted position and remove pretzel clip (3).
3. While firmly holding the jiffy stand leg (5) in the fully retracted position, withdraw the clevis pin (1) until it disengages from the upper pivot hole of the jiffy stand yoke (4).
4. Detach the spring (6) from the anchor pin (7) using pliers. Unhook other end of spring from the jiffy stand leg.
5. Remove the clevis pin from the lower pivot hole of the jiffy stand yoke. Remove jiffy stand leg and discard.
6. Clean the frame mounted anchor pin and apply a small amount of wheel bearing grease to the pivot holes of the new jiffy stand leg (5) and yoke, groove of anchor pin and shaft of clevis pin (1).

NOTE

When installing the jiffy stand spring, make sure the open ends of the spring hooks face inward toward the center of the vehicle.

7. Hook either end of the spring (6) into the spring mounting hole on the jiffy stand leg (5). Install the other end of the spring over the frame mounted anchor pin (7).
8. Install the bushing (2) onto the clevis pin (1) with the shoulder of the bushing facing the head of the clevis pin.

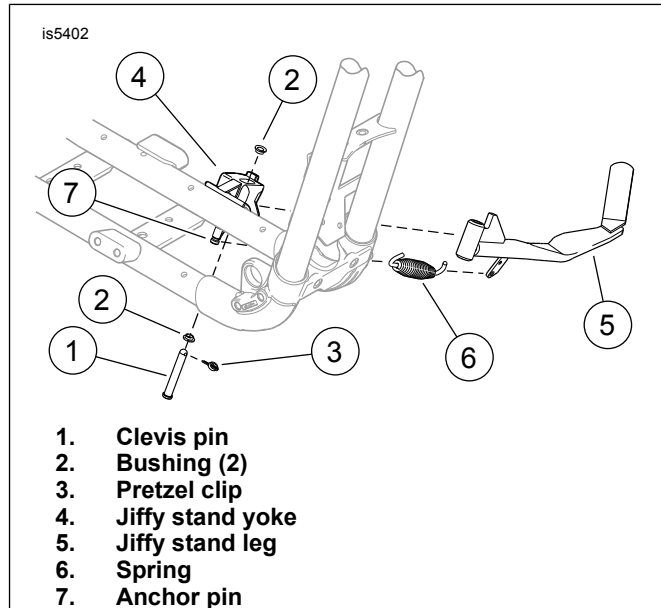

Figure 2. Jiffy Stand

9. While holding the end of the spring in the groove of the anchor pin and holding the jiffy stand leg in its retracted position, place the pivot end of the stand leg into the yoke (4) on the motorcycle frame. Insert the clevis pin (1) up through the lower pivot hole of the yoke and halfway into the pivot hole of the jiffy stand leg.
10. Lift the jiffy stand leg upward, aligning the pivot hole of the jiffy stand leg with the slotted upper hole of the yoke (7). Push the clevis pin through the upper hole in the yoke. Make certain that the shank of the lower bushing (3) fits inside the lower pivot hole in the yoke.
11. Install the upper bushing with the shoulder facing up, over the end of the clevis pin and against the upper surface of the yoke. Insert the pretzel clip (2) through the hole in the end of the clevis pin.
12. Press the rubber bumper (5) onto the mounting stud of the frame.
13. Extend and retract the stand several times to check for proper operation. In a retracted position (up), the jiffy stand leg should be securely seated against the frame mounted rubber bumper.
14. Place the jiffy stand in its full forward position (down). Carefully remove the support blocking from beneath the motorcycle frame. Rest the motorcycle on the jiffy stand.

SERVICE PARTS

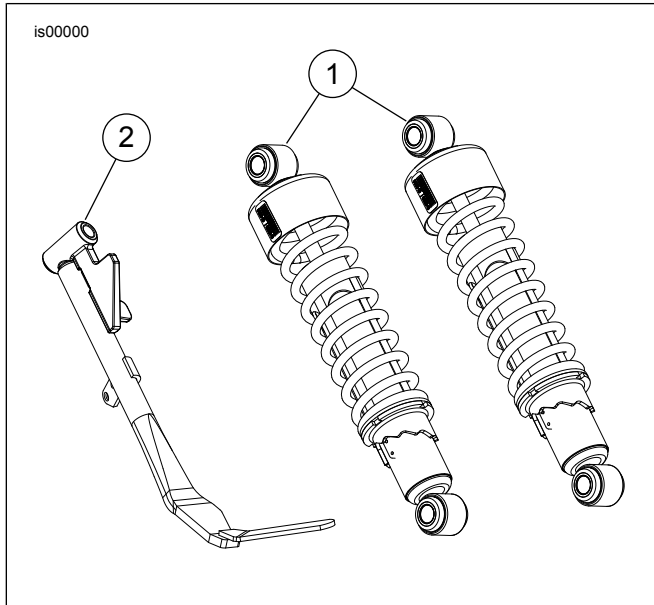

Figure 3. Service Parts: Low Rear Shock Kit

Table 1. Service Parts

Item	Description (Quantity)	Part Number
1	Shock absorber (2)	54568-09
2	Jiffy stand	50185-04B