



INSTRUCTIONS

J04880

2009-06-15



RAZOR-PAK KIT

GENERAL

Kit Number

79175-10XXX

Models

For model fitment information, see the P&A Retail Catalog or the Parts and Accessories section of www.harley-davidson.com (English only).

Additional Parts Required

Separate purchase of Backrest Pad (79192-10) is required for installation of this kit. See your Harley-Davidson dealer.

Separate purchase of a Tour-Pak rack is required for installation of this kit. See your Harley-Davidson dealer.

For Kit 79175-10BDK: A service manual for your model motorcycle is required for this installation and is available from a Harley-Davidson dealer.

Kit Contents

See Figure 2 and Table 1.

INSTALLATION

Drill the Mounting Holes in the Razor-Pak

1. Remove the loose hardware and rubber mat lining the bottom of the Razor-Pak and set aside.

NOTE

See Figure 1. There are drilling points (1, 2) molded into the bottom of the Razor-Pak to use as guides for drilling. Only drill holes in the drill points that match the mounting holes in the Tour-Pak rack.

Patterns 1 and 1A have four holes each and Pattern 2 has five holes.

2. Set the Tour-Pak rack on the Razor-Pak and determine which mounting hole pattern needs to be drilled. Pattern 1 has two positions to adjust Razor-Pak position relative to seat.
3. Apply masking tape to the outside painted or primed surface of the Razor-Pak at the appropriate drill points. This will protect the finish during the drilling operation.
4. Place a clean, soft cloth on the workbench and place the Razor-Pak with the bottom facing up.

NOTE

Drilling each hole is a two-step procedure that requires a specific type of drill bit to avoid damaging the Razor-Pak.

5. Use a 5/16 or 3/8-inch spade bit or unibit (do **not** use a spiral-type bit) to drill the holes from the outside of the Razor-Pak through the drill points. Stop drilling when the tip of the bit just pierces the inside surface of the Razor-Pak.
6. Turn the Razor-Pak over and complete each hole with the same drill bit at each of the pierced holes. Clean excess material from the holes and clean the Razor-Pak of any debris.

Assemble the Razor-Pak (Kit 79175-10BDK only)

1. After painting the primed parts, assemble the Razor-Pak following the instructions for the Tour-Pak in the service manual.

Install the Razor-Pak to Tour-Pak Rack

1. Align the holes in the base of the Razor-Pak with the mounting holes on the Tour-Pak rack.

NOTE

Replace the washer in the Tour-Pak rack installation kit with washer (30) from this kit.

2. See Figure 2. Insert the screws through the washers (30) and the newly-drilled mounting holes from the inside of the Razor-Pak. Tighten per the instructions in the Tour-Pak rack instruction sheet.
3. Install the black rubber mat in the Razor-Pak.

⚠ WARNING

Do not exceed Tour-Pak weight capacity. Too much weight can cause loss of control, which could result in death or serious injury. (00401c)

NOTE

See the Razor-Pak warning label for the maximum Razor-Pak weight capacity.



is06217

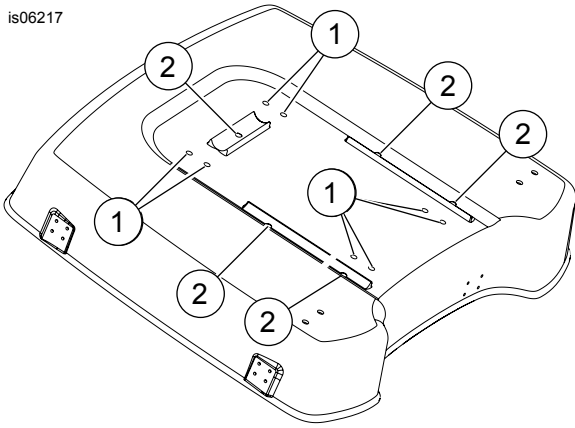

- 1. Drilling points - pattern 1 and 1A
- 2. Drilling points - pattern 2

Figure 1. Mounting Hole Patterns

SERVICE PARTS

is06218

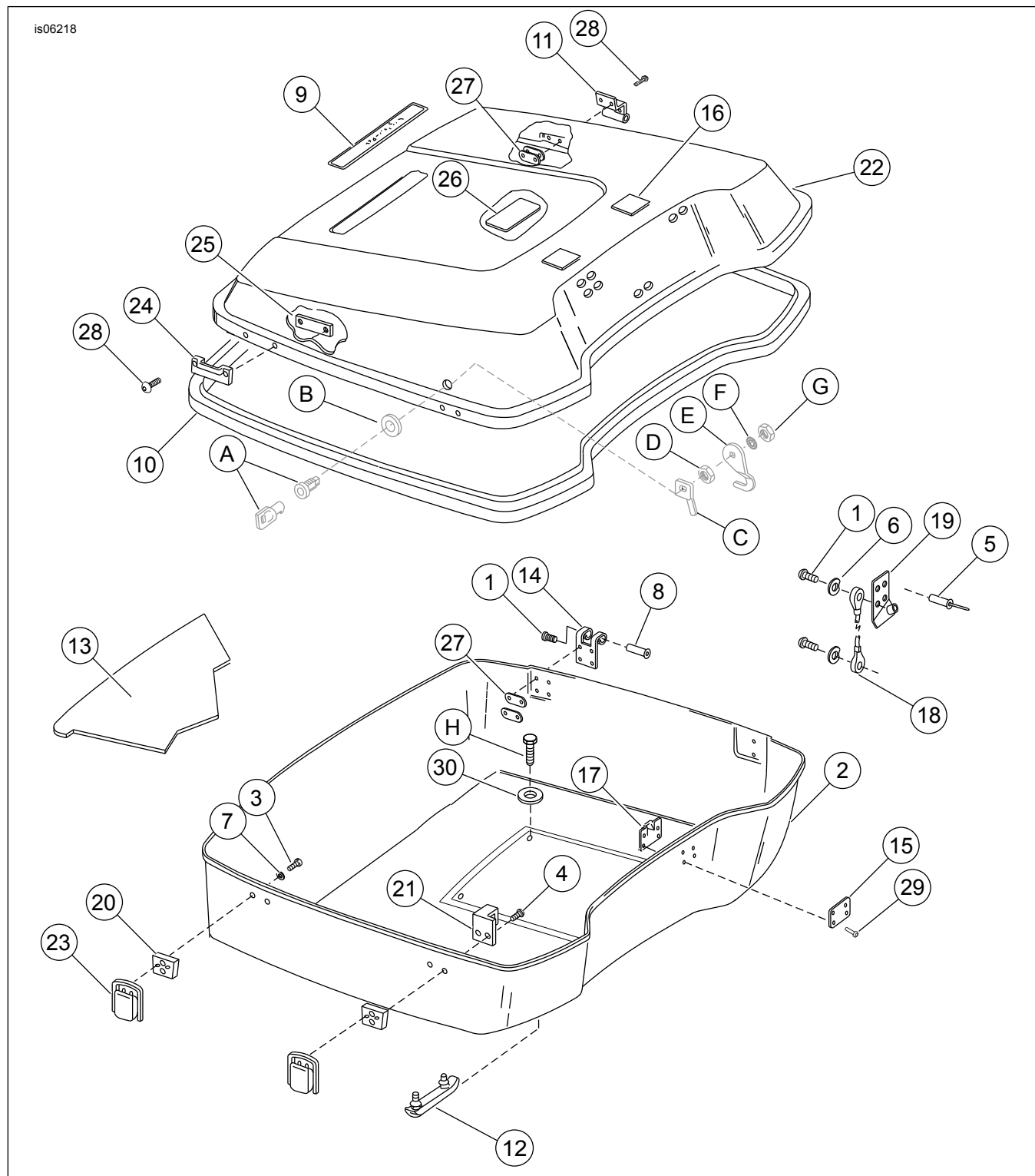

Figure 2. Service Parts: Razor Tour-Pak

Table 1. Service Parts Table

Item	Description (Quantity)	Part Number
1	Screw, 6-32 x 3/8 in. (4)	3595
2	Razor-Pak bottom	Not Sold Separately
3	Screw, 6-32 x 9/16 in. (2)	3597
4	Screw, 6-32 x 3/4 in. (2)	3598
5	Rivet (2)	58709-86

Table 1. Service Parts Table

Item	Description (Quantity)	Part Number
6	Spring washer (2)	6970
7	Plain washer, No. 6 (2)	6029
8	Hinge pin (2)	8538
9	Trim plate	54048-09
10	Cover gasket	53415-06
11	Hinge, cover - upper (2)	53426-87
12	Bumper (2)	53429-93
13	Mat, Razor-Pak bottom	53109-96
14	Hinge, lower (2)	53447-87
15	Backing plate, brace	53478-80
16	Pad (2)	53486-85
17	Bracket, cable mounting	53563-82
18	Cable	53564-97
19	Bracket, cable mounting, lid side	53570-89
20	Spacer (2)	53615-85A
21	Catch, lower	53616-85
22	Razor-Pak cover (XXX is color code)	79047-09XXX
23	Body, catch (2)	90649-07
24	Catch, upper (2)	90705-97
25	Backing plate (2)	90688-85
26	Label, load limit	90821-74C
27	Backing plate (8)	90964-63
28	Rivet (20)	90965-63
29	Rivet (4)	90967-64
30	Washer (5)	6253W
Items referenced in text, but not included in kit:		
H	Fastener	Included with Tour-Pak Rack Installation Kit
Kit 53194-07 - Lock kit (purchased separately): Includes items A-G. Refer to lock kit instruction sheet for complete assembly and installation instructions.		
Note: Hardware Kit (90701-09) is available for separate purchase. Includes items 1, 3-12, 14-21, 23-30.		