



INSTRUCTIONS

J04544

2011-03-15



PREMIUM TOUR-PAK HINGE KIT

GENERAL

Kit Number

79211-08A, 53000131

Models

This kit is a direct replacement for the original equipment (OE) polished Tour-Pak® hinges.

For model fitment information, see the P&A retail catalog or the Parts and Accessories section of www.harley-davidson.com (English only).

Tools and Supplies Required

Loctite® 262 Threadlocker and Sealant - Red (H-D Part Number 94759-99) is required for the proper installation of this kit.

Kit Contents

See Figure 2 and Table 1.

INSTALLATION

NOTE

With the tether unfastened, use caution to keep the Tour-Pak lid from opening beyond the normal 90 degree of travel or damage to painted surfaces can occur.

1. See Figure 1. Remove the screw (2) from the threaded boss on the Tour-Pak lid tether bracket (1). Remove the tether eyelet (3) and spring washer (4, behind 3) from the threaded boss, and save for assembly.

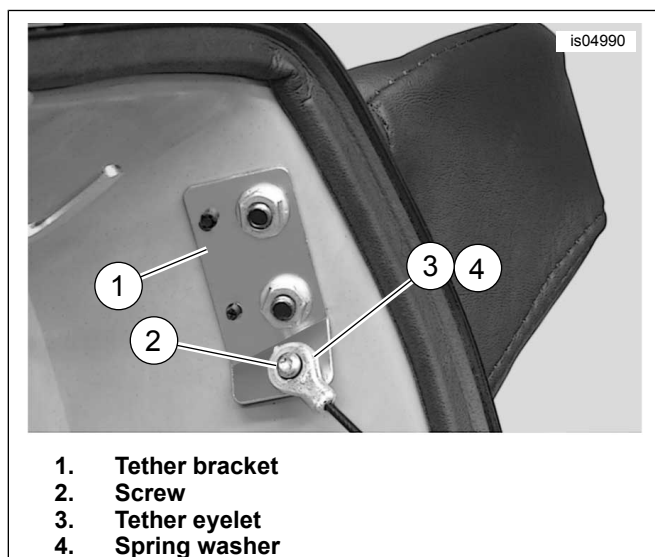

1. Tether bracket
2. Screw
3. Tether eyelet
4. Spring washer

Figure 1. Tour-Pak Lid Tether

2. Holding the inboard side of one of the Tour-Pak hinge pins with a T-25 TORX bit, use a T-15 TORX bit to remove the hinge pin screw. Remove the hinge pin from the hinge. Repeat for the second hinge.
3. Carefully remove the Tour-Pak lid and set it aside on clean shop towels to avoid damage to painted surfaces.
4. Using a 3/16 inch (5 mm) drill bit from the **inside** of the Tour-Pak base, drill out the eight hinge rivets.

NOTE

Be extremely careful when drilling out the four hinge rivets beneath the lid gasket seal. Compress the gasket during drilling to avoid damage from the drill bit or chuck, which can lead to seal failure.

5. From the inside of the Tour-Pak lid, use the 3/16 inch (5 mm) bit to drill out the remaining eight hinge rivets. Remove and discard the hinge halves and backing plates.
6. See Figure 2. Obtain one hinge assembly (1), two small hinge backing plates (2) and four screws (4) from the kit.
7. From the outside of the Tour-Pak base, align the four holes of the lower hinge body with the four holes in the base. From the **inside** of the Tour-Pak, align one of the backing plates with the two lower holes inside the base.
8. Apply a few drops of Loctite 262 - Red to the threads of two of the screws. Loosely install the hinge and backing plate with the screws.
9. Align the second backing plate with the two upper holes inside the base, apply Loctite to the threads of the remaining two screws, and loosely fasten the hinge and backing plate with the screws. Tighten all four screws to 2.3–2.8 N·m (20–25 in-lbs).
10. Repeat Steps 6 through 9 for the second hinge. Place both upper hinge sections into the full open position.
11. Obtain the Tour-Pak lid, and position the lid onto the hinges so the pins (A) on the back side of the upper hinge sections fully engage the mating holes in the lid flange (under the gasket). This will help support the lid. The top four holes (B) in the upper hinges should align with the holes in the lid.
12. Obtain the screw, eyelet and spring washer removed from the tether in Step 1. Reassemble the tether to the Tour-Pak lid.

- a. With the concave side toward the tether bracket, install the spring washer onto the threaded boss.



- b. Install the tether eyelet onto the threaded boss.
- c. Apply a small amount of Loctite 262 (Red) to the threads of the tether screw.
- d. Install the screw into the threaded boss and tighten to 2.3–2.8 N·m (20–25 **in-lbs**).

13. Obtain the remaining two small hinge backing plates (2), two upper hinge backing plates (3), and eight screws (4) from the kit.

14. Assemble the hinges to the Tour-Pak lid.

- a. From the **inside** of the Tour-Pak lid, install the two small holes of an upper hinge backing plate over the pins on one hinge as shown. The two lower holes should align with the lower holes (C) in the upper hinge body.
- b. Apply a few drops of Loctite 262 (Red) to the threads of two of the screws. Loosely fasten the hinge and backing plate with the screws.
- c. Align the small backing plate with the two upper holes inside the lid, apply Loctite to the threads of two screws, and loosely fasten the hinge and backing plate with the screws.
- d. Repeat Steps 14a through 14c for the remaining hinge.
- e. Alternately tighten all eight screws to 2.3–2.8 N·m (20–25 **in-lbs**).

Table 1. Service Parts

Item	Description (Quantity)	Part Number
A	Pin (2) on back side of upper hinge section	
B	Top hole (2) in upper hinge section	
C	Lower hole (2) in upper hinge section	

SERVICE PARTS

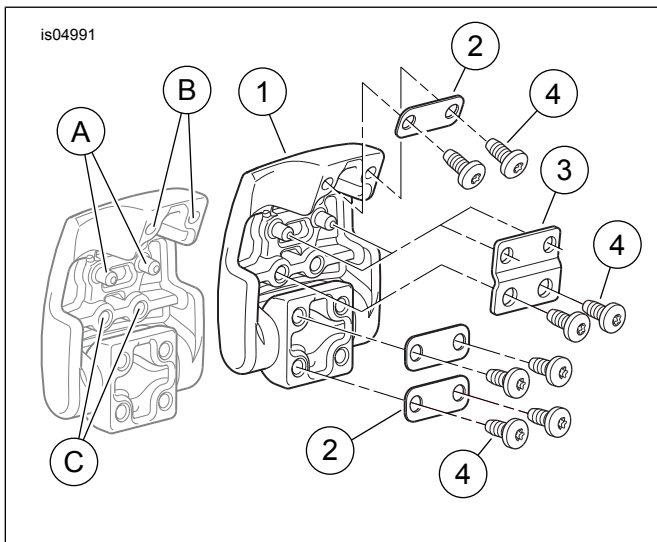

Figure 2. Service Parts, Tour-Pak Hinge Kit

Table 1. Service Parts

Item	Description (Quantity)	Part Number
1	Hinge assembly, chrome (2)	Not Sold Separately
	Hinge assembly, black (2)	Not Sold Separately
2	Hinge backing plate, small (6)	79216-08
3	Hinge backing plate, upper (2)	79218-08
4	Screw, T-20 TORX head (16)	2480
Items mentioned in text.		