



INSTRUCTIONS

J04455

2009-02-12



FLSTF TURN SIGNAL RELOCATION KIT

GENERAL

Kit Number

69929-07, 73369-10

Models

For model fitment information, see the P&A Retail Catalog or the Parts and Accessories section of www.harley-davidson.com (English only).

Additional Parts Required

⚠ WARNING

Rider and passenger safety depend upon the correct installation of this kit. Use the appropriate service manual procedures. If the procedure is not within your capabilities or you do not have the correct tools, have a Harley-Davidson dealer perform the installation. Improper installation of this kit could result in death or serious injury. (00333b)

NOTE

This instruction sheet references service manual information. A service manual for your model motorcycle is required for this installation and is available from a Harley-Davidson dealer.

Loctite® 243 (blue) Part Number 99642-97 is available from a Harley-Davidson dealer.

Kit Contents

See Figure 7 and Table 1.

REMOVAL

1. Remove seat according to the instructions in the service manual.

⚠ WARNING

To prevent accidental vehicle start-up, which could cause death or serious injury, disconnect battery cables (negative (-) cable first) before proceeding. (00307a)

⚠ WARNING

Disconnect negative (-) battery cable first. If positive (+) cable should contact ground with negative (-) cable connected, the resulting sparks can cause a battery explosion, which could result in death or serious injury. (00049a)

2. See Figure 1. Disconnect battery cables, negative (-) cable first.

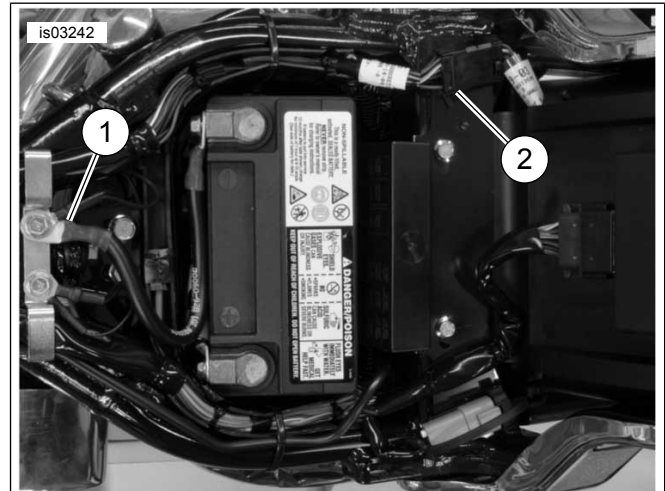

1. Negative (-) cable
2. Tail lamp connector

Figure 1. Negative Battery Cable and Tail Lamp Connector

3. See Figure 2. Remove two screws and tail lamp lens (1) from base (2).

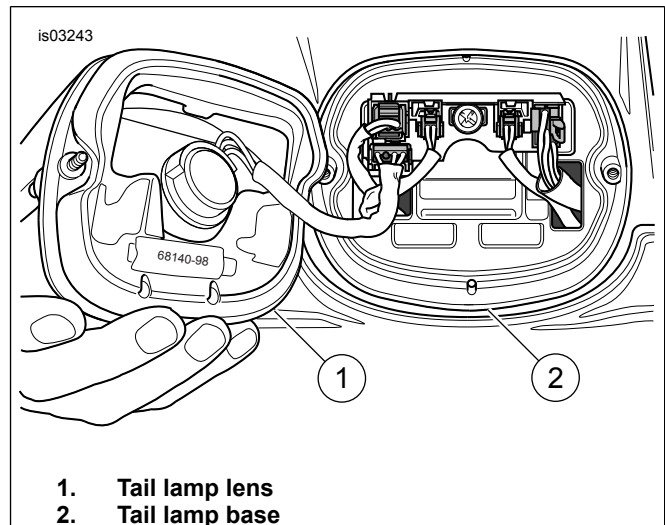

1. Tail lamp lens
2. Tail lamp base

Figure 2. Remove Tail Lamp Lens

4. See Figure 3. Using a Terminal Pick Tool (1), press locking tabs and disconnect turn signal connectors (2-place) (2, 3) from circuit board.
5. Feed turn signal wiring and connector through opening in circuit board assembly and into rear wheel area.
6. See Figure 4. Remove turn signal wiring (1, 2) from clips (3) under rear of fender.

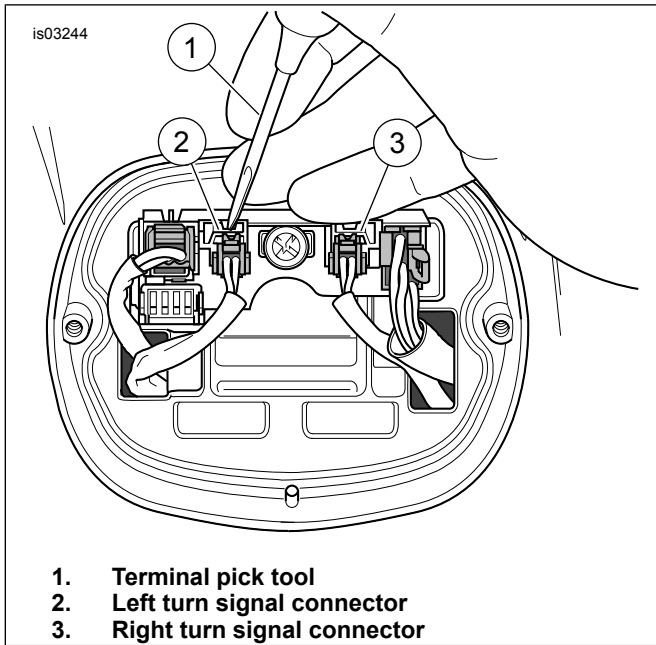

Figure 3. Remove Turn Signal Connectors

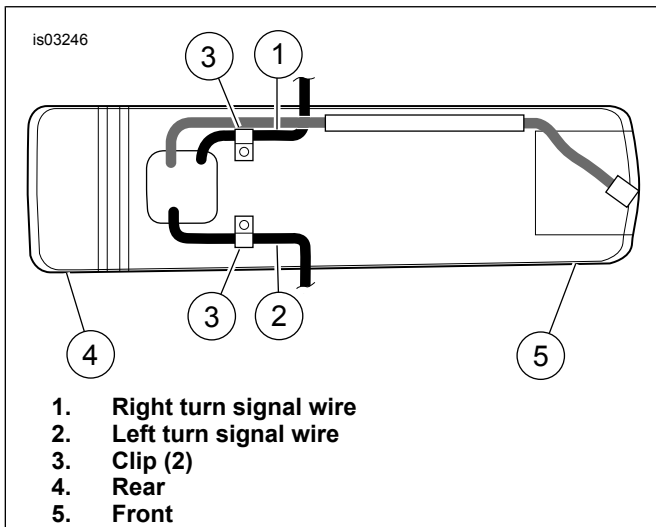

Figure 4. Turn Signal Wires and Clips (Viewed from Bottom Inside Rear Fender)

INSTALLATION

NOTE

Proper installation of kit requires that tasks be completed for one side of the motorcycle first before continuing to the opposite side.

Route Turn Signal Wiring Through Rear Fender and Support

1. See Figure 5. Remove three rear screws (1) from fender support (2).
2. Loosen, but do not remove two front screws (3) from fender support.

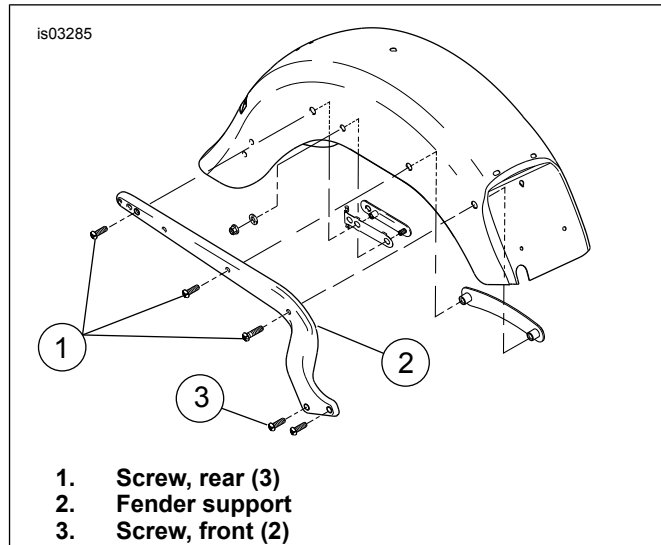

Figure 5. Fender Support Screws and Fender Support

3. Pull fender support away from rear fender to gain access to turn signal mount.
4. Remove stock screw and washer from turn signal mount.
5. See Figure 7. Pull turn signal (B) and turn signal mount (A) away from fender support.
6. Remove turn signal and wires from vehicle by routing turn signal wiring and connector through holes in rear fender and fender support. Gently guide wires through holes to verify they do not get damaged.

Feed Wiring and Install Relocation Bracket

1. See Figure 6. Feed turn signal wiring and connector through middle hole in turn signal relocation bracket and under rear of fender support.

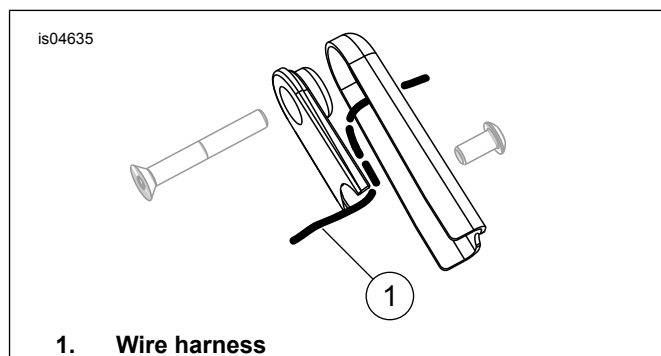

Figure 6. Wire Harness Routing

2. See Figure 7. Insert stock screw and washer through rear hole of relocation bracket (1) and turn signal mount (A).
3. Thread screw into turn signal (B). Tighten to 12-16 ft-lbs (16.3-21.7 Nm).
4. Align relocation bracket (1) with rear of fender support and install with screw (2) and nut (3) from kit. Tighten nut to 12-16 ft-lbs (16.3-21.7 Nm).

Complete Turn Signal Relocation Wiring

1. See Figure 5. Install one rear screw (1) to hold fender support in place while routing wiring. Install screw snugly but do not fully tighten.
2. Remove slack in turn signal wiring from inside rear fender.
3. See Figure 4. Secure turn signal wiring inside rear fender using clip.
4. Route turn signal connector through opening in tail light/license plate bracket above circuit board.
5. Make sure there is no loose wire in wheel compartment. Adjust wire routing if necessary.
6. See Figure 7. Connect pin housing of harness extension (4) into turn signal connector. Then connect socket housing of harness extension into appropriate connector in circuit board.

Install Opposite Turn Signal

After completing the installation for one side of the motorcycle, repeat the same tasks to install the turn signal relocation kit to the opposite side.

Final Assembly

1. Neatly bundle turn signal wiring and wire harness extension in circuit board area. Use cable ties (5) from kit if necessary.

NOTE

Do not allow wire harness extension or turn signal connector to go into rear wheel area. Contain completely in circuit board area.

SERVICE PARTS

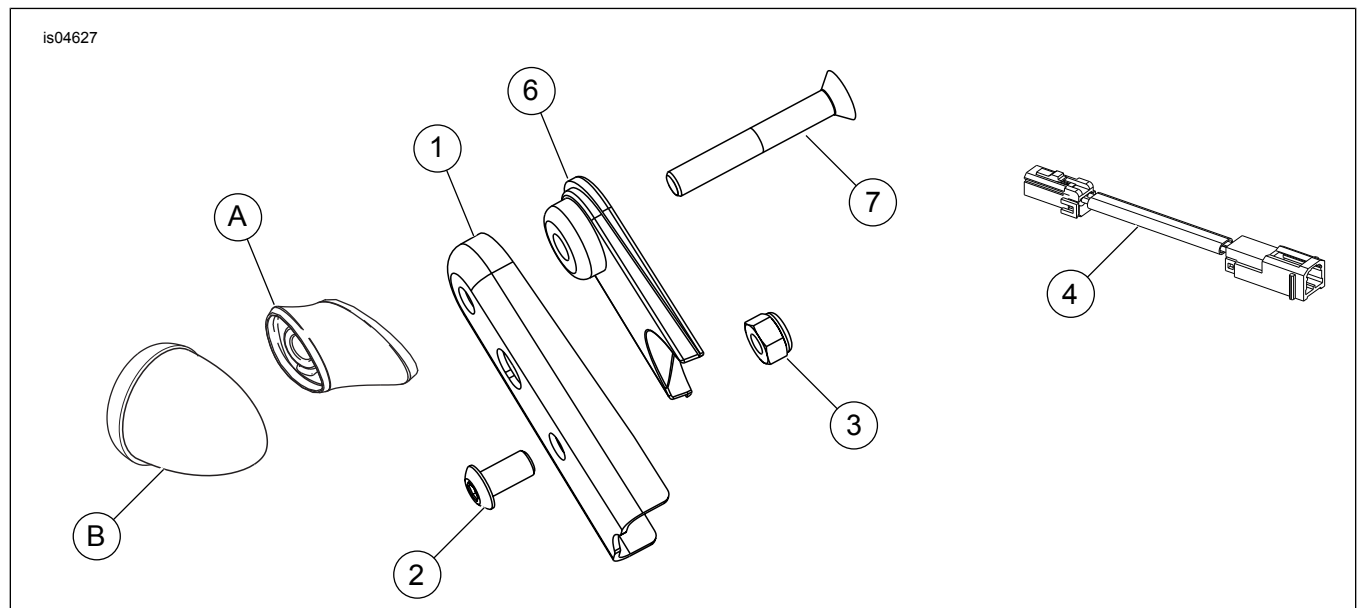

Figure 7. Service Parts: Turn Signal Relocation Kit

Table 1. Service Parts: Turn Signal Relocation Kit

Item	Description (Quantity)	Part Number
1	Bracket, turn signal relocation, chrome (2), (kit 69929-07) Bracket, turn signal relocation, black, (2), (kit 73369-10)	Not Sold Separately Not Sold Separately
2	Screw, 5/16-18 x 5/8 in. (2)	3540
3	Nut, Nylock 5/16-18 (2)	7739
4	Wire harness extension (2)	70621-07

2. See Figure 2. Install tail lamp lens (1) on base (2) using two screws.

⚠ WARNING

Connect positive (+) battery cable first. If positive (+) cable should contact ground with negative (-) cable connected, the resulting sparks can cause a battery explosion, which could result in death or serious injury. (00068a)

3. Connect battery cables, positive (+) cable first.

⚠ WARNING

After installing seat, pull upward on seat to be sure it is locked in position. While riding, a loose seat can shift causing loss of control, which could result in death or serious injury. (00070b)

4. Install seat according to the instructions in the service manual.

⚠ WARNING

Be sure that all lights and switches operate properly before operating motorcycle. Low visibility of rider can result in death or serious injury. (00316a)

5. Check turn signals for proper operation.

Table 1. Service Parts: Turn Signal Relocation Kit

Item	Description (Quantity)	Part Number
5	Strap, cable (2) (Not Shown)	10065
6	Cover, back	Not Sold Separately
7	Screw	4845
Original equipment parts, not included in kit:		
A	Turn signal mount(2)	
B	Turn signal (2)	