



INSTRUCTIONS

J05170

2010-04-15



SOFTAIL EXTENDED REACH BRAKE LINE KIT

GENERAL

Kit Number

41800004, 41800005

Models

For model fitment information, see the P&A Retail Catalog or the Parts and Accessories section of www.harley-davidson.com (English only).

Additional Parts

NOTE

These kits **CANNOT** be used with the following accessories:

- Engine guard (Part Number 49200-07)
- Rear master cylinder cover (Part Number 45665-01)

In addition to the parts from the kit, LOCTITE® 243 (blue) Threadlocker and Sealant (Part Number 99642-97), Harley-Davidson Wheel Bearing Grease (Part Number 99855-80) and DOT 4 Brake Fluid (Part Number 99953-99A) are also required for installation.

For accessories and kit part numbers see your local Harley-Davidson dealer, www.harley-davidson.com or your Harley-Davidson Genuine Motor Accessories and Parts catalog.

NOTE

This instruction sheet references service manual information. A service manual for your model motorcycle is required for this installation and is available from a Harley-Davidson Dealer.

Kit Contents

See Figure 4 and Table 1.

INSTALLATION

Prepare the Motorcycle

1. If equipped with saddlebags, remove the saddlebags following the instructions in the service manual.
2. Remove the seat following the directions in the owner's manual.

⚠ WARNING

To prevent accidental vehicle start-up, which could cause death or serious injury, disconnect negative (-) battery cable before proceeding. (00048a)

3. Disconnect the negative battery cable.

4. Secure motorcycle in upright position.
5. Disconnect the harness from the stoplamp switch (3).

NOTICE

Remove brake line components carefully. Damage to seating surfaces can cause leakage. (00320a)

6. Remove brake line following the instructions in the service manual.

Install Brake Line

⚠ WARNING

Be sure that no lubricants or fluids get on tires, wheels or brakes when changing fluid. Traction can be adversely affected, which could result in loss of control of the motorcycle and death or serious injury. (00047d)

1. Connect the stoplamp switch and install the new rear brake line from the brake line kit following the instructions in the service manual.

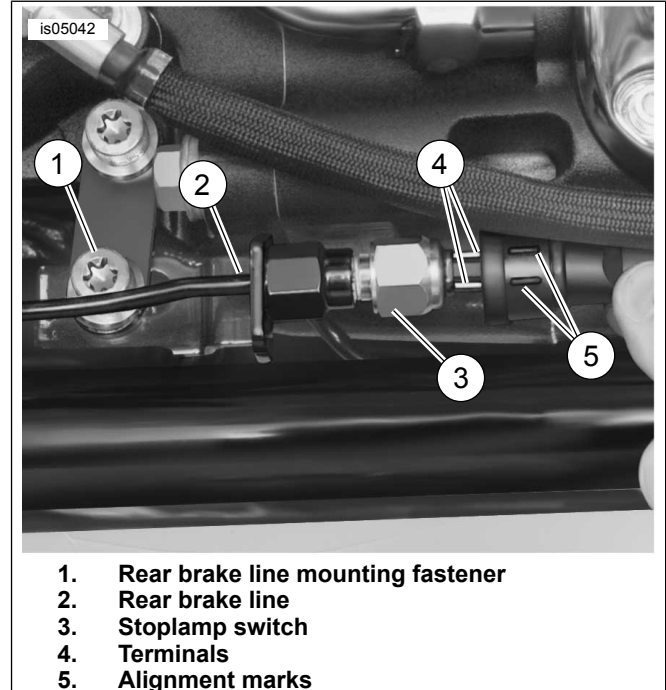
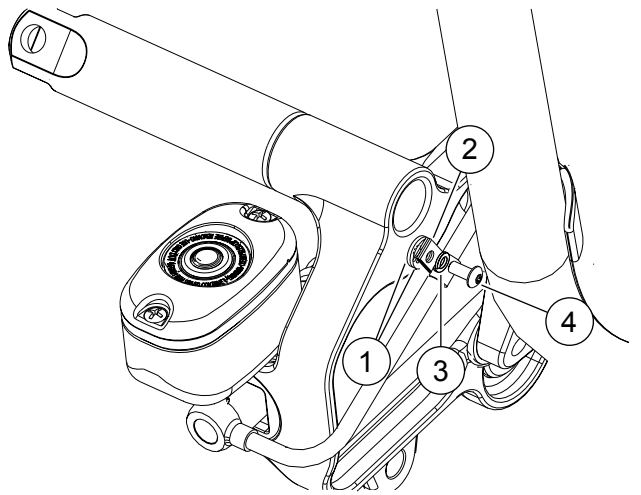

Figure 1. Brake Line Bracket and Stoplamp Switch



1. Flat washers (2)
2. Brakeline clamp
3. Lock Washer
4. Screw

Figure 2. Brakeline Fastening Hardware

⚠ WARNING

Use denatured alcohol to clean brake system components. Do not use mineral-based solvents (such as gasoline or paint thinner), which will deteriorate rubber parts even after assembly. Deterioration of these components can cause brake failure, which could result in death or serious injury. (00291a)

2. See Figure 2. Install the clamp (2) around the brake line with two flat washers (1) behind the clamp. Use screw (4) with lock washer (3) and tighten fastener to 3.4 N·m (30 in-lbs)
3. Be sure that the brake line runs parallel to the rear of the brake lever bracket and that the brake line does not rub against any part of the bracket.
4. See Figure 3. Install the cable straps at locations (1).
5. Bleed the brakes following the instructions in the service manual.

NOTE

Hydraulic brake fluid bladder-type pressure equipment can be used to fill brake master cylinder through the bleeder valve. Remove the master cylinder reservoir cover so that the system cannot pressurize. Do not use pressure bleeding equipment when the hydraulic system is sealed with master cylinder reservoir cover and gasket in place.

NOTE

The sight glass enables the rider to visually check the brake fluid level without removing the master cylinder cover. When the reservoir is full, the sight glass is dark. As the fluid level drops, the glass lightens up to indicate this condition to the rider.

⚠ WARNING

Be sure that no lubricants or fluids get on tires, wheels or brakes when changing fluid. Traction can be adversely affected, which could result in loss of control of the motorcycle and death or serious injury. (00047d)

⚠ WARNING

Contact with DOT 4 brake fluid can have serious health effects. Failure to wear proper skin and eye protection could result in death or serious injury.

- If inhaled: Keep calm, remove to fresh air, seek medical attention.
- If on skin: Remove contaminated clothing. Rinse skin immediately with plenty of water for 15-20 minutes. If irritation develops, seek medical attention.
- If in eyes: Wash affected eyes for at least 15 minutes under running water with eye lids held open. If irritation develops, seek medical attention.
- If swallowed: Rinse mouth and then drink plenty of water. Do not induce vomiting. Contact Poison Control. Immediate medical attention required.
- See Safety Data Sheet (SDS) for more details available at sds.harley-davidson.com

(00240e)

6. Add brake fluid, if necessary, following the instructions in the owner's manual.

Return to Service

1. For models equipped with saddlebags: Install the saddlebags following the instructions in the service manual.
2. Connect the negative battery cable.

⚠ WARNING

After installing seat, pull upward on seat to be sure it is locked in position. While riding, a loose seat can shift causing loss of control, which could result in death or serious injury. (00070b)

3. Install the seat following the instructions in the owner's manual.

⚠ WARNING

The jiffy stand locks when placed in the full forward (down) position with vehicle weight on it. If the jiffy stand is not in the full forward (down) position with vehicle weight on it, the vehicle can fall over which could result in death or serious injury. (00006a)

⚠ WARNING

Be sure jiffy stand is fully retracted before riding. If jiffy stand is not fully retracted, it can contact the road surface causing a loss of vehicle control, which could result in death or serious injury. (00007a)

4. Test jiffy stand operation.

- With the ignition/light key switch turned to IGNITION, actuate the rear brake pedal to verify operation of the brake lamp.

⚠ WARNING

After repairing the brake system, test brakes at low speed. If brakes are not operating properly, testing at high speeds can cause loss of control, which could result in death or serious injury. (00289a)

- Test ride the motorcycle. If the brake feels soft, repeat the rear brake bleeding procedure.



Figure 3. Cable Strap Location

Service Parts

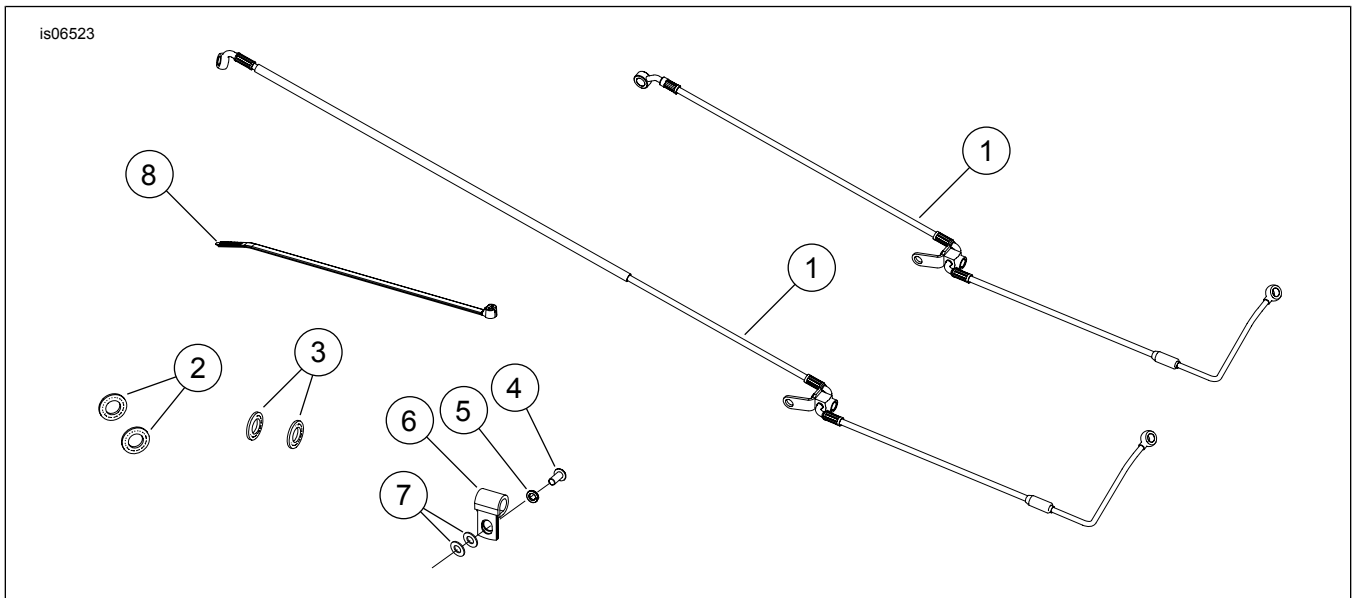

Figure 4. Service Parts: Extended Reach Brakeline Kit

Table 1. Service Parts Table

Kit	Item	Description (Quantity)	Part Number
Kit 41800004, ABS	1	Brakeline assembly, rear, ABS	41800006
	2	Gasket, brakeline (2)	41733-88
	3	Gasket, brakeline (2)	41731-01
	4	Screw, #8 - 32, 0.38 LG	94634-99
	5	Lock washer, #8	7015
	6	Clamp, brakeline	10106
	7	Washer, flat (2) Gasket	6192
	8	Cable strap (2)	10006

Table 1. Service Parts Table

Kit	Item	Description (Quantity)	Part Number
Kit 41800005 NON-ABS	1	Brakeline assembly, rear, NON-ABS	41800007
	2	Gasket, brakeline (4)	41733-88
	4	Screw, #8 - 32, 0.38 LG	94634-99
	5	Lock washer, #8	7015
	6	Clamp, brakeline	10106
	7	Washer, flat (2)	6192
	8	Cable strap (2)	10006