



INSTRUCTIONS

J04796

2015-04-21



HANDLEBAR KIT

GENERAL

Kit Number

55977-09A

Models

Ask a Harley-Davidson dealer or refer to the latest Harley-Davidson Genuine Motor Accessories and Genuine Motor Parts catalog to determine if this handlebar can be installed on your motorcycle.

This kit does not fit models equipped with Heated Hand Grips, Softail Nacelle Kit (67907-96), Hydraulic Clutch Kits, handlebar-mounted gauges or the Road Tech® Radio.

Additional Parts or Accessories Required

Separate purchase of additional parts or accessories may be required for proper installation of this handlebar kit on your model motorcycle. Refer to the latest Harley-Davidson Genuine Motor Accessories and Genuine Motor Parts catalog for a list of required parts or accessories for your model.

Loctite® 271 (Red) Threadlocker and Sealant (99671-97) is required for the proper installation of this kit.

Fresh, uncontaminated brake fluid is also needed. Refer to your owner's manual or the service manual to determine the correct brake fluid.

⚠ WARNING

Replace brake line gaskets. Re-using original gaskets can cause brake failure and loss of vehicle control, which could result in death or serious injury. (00318a)

For models that reuse the original brake line, the two sealing gaskets found at each banjo fitting **must be replaced**. Refer to the appropriate Parts Catalog or see a Harley-Davidson dealer for the correct part numbers.

Motorcycles equipped with a **glued** left side hand grip require a new grip, sold separately. Refer to the Parts Catalog for replacement stock hand grips.

Ask a Harley-Davidson dealer about the selection of Genuine Motor Accessory hand grips that are available.

⚠ WARNING

Rider and passenger safety depend upon the correct installation of this kit. Use the appropriate service manual procedures. If the procedure is not within your capabilities or you do not have the correct tools, have a Harley-Davidson dealer perform the installation. Improper installation of this kit could result in death or serious injury. (00333b)

NOTE

This instruction sheet references service manual information. A service manual for your model motorcycle is required for this installation and is available from a Harley-Davidson dealer.

Kit Contents

See Figure 2 and Table 1.

REMOVAL

See the service manual for removal procedures.

INSTALLATION

See the service manual and follow the wiring procedures.

NOTE

***For Non-FXDF Models Only:** See Figure 2. Cut the mesh tubing from the kit into two equal length pieces. Slide the switch wire bundles through mesh conduit. Position conduit into switch control housing. Tie each end of conduit with cable strap from kit.*

Handlebar Installation

See the service manual and follow the installation procedures.

For 2016 and later Softail Models:

Reuse the stock twist grip sensor with the smaller internal wire bundle.

NOTE

*This installation is not compatible with heated hand grips so the shorter, heated handgrip portion of the twist grip sensor wiring **WILL NOT BE USED** in this installation. Those wires can be cut short and taped off to avoid interference with the installation, or left bundled and taped inside the handlebar.*

1. Tape the ends of the longer pair of harness bundles together tight enough to be passed easily through the handlebar. Apply a light coat of liquid soap, window cleaner, or all-purpose lubricant to the **twist grip sensor** wire bundle.
2. See Figure 1. Feed the twist grip sensor wire bundle into the right-side handlebar end and toward the large opening in the center of the bar, while fitting the index tabs on the twist grip sensor into the slots on the end of the handlebar. Different-sized tabs and slots prevent improper assembly.

NOTE

The twist grip sensor must be fully seated for correct function.



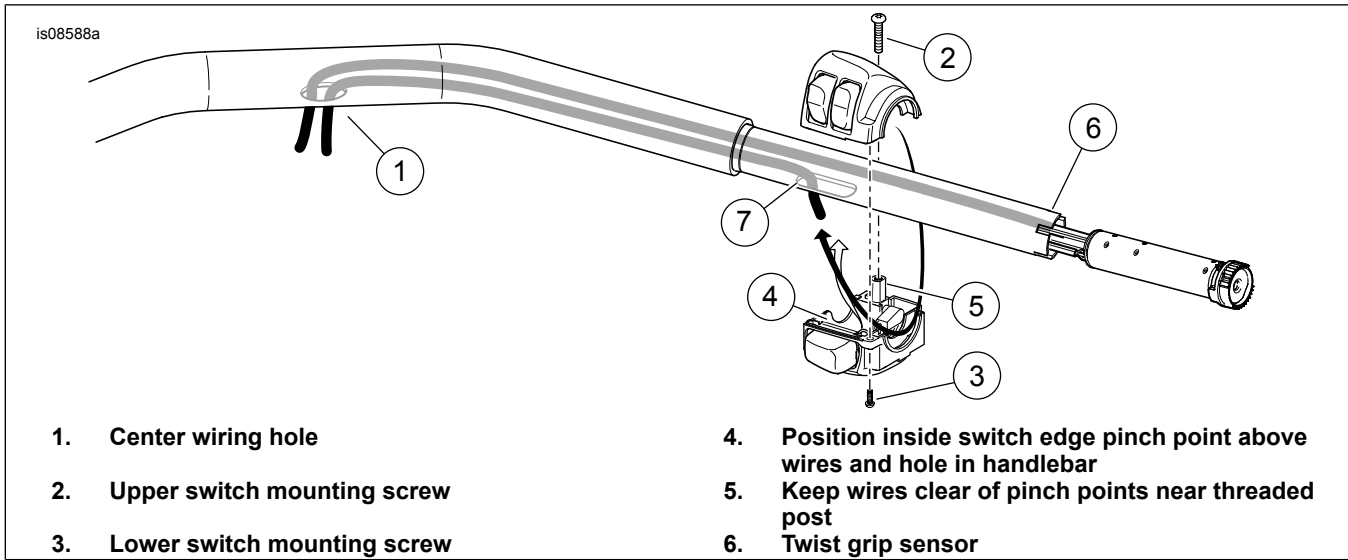

Figure 1. Switch Housing and Twist Grip Sensor Wire Routing (2016 and Later Softail)

SAFETY CHECK

⚠ WARNING

Be sure that steering is smooth and free without interference. Interference with steering could result in loss of vehicle control and death or serious injury. (00371a)

- Lines must not catch on headlamp hardware or pass in front of headlamp.
 - Lines must not catch on turn signal mounting hardware or turn signals.
 - Lines must not catch on fuel cap.
 - Lines must not catch on speedometer.
 - Make sure that lines are not pinched between the frame and/or forks.
 - Make sure that clutch line does not pull tight when handlebar is turned fully to left or right fork stops.
 - Make sure control wires/jumpers do not pull tight when handlebars are turned fully to left or right fork stops.
1. Verify that the ignition/light key switch is turned to OFF. Install main fuse.

⚠ WARNING

Be sure that all lights and switches operate properly before operating motorcycle. Low visibility of rider can result in death or serious injury. (00316a)

2. Turn the ignition/light key switch to IGNITION, but do not start the engine. Test all switches and lights for proper operation.

⚠ WARNING

Before starting engine, be sure throttle control will snap back to idle position when released. A throttle control that prevents engine from automatically returning to idle can lead to loss of control, which could result in death or serious injury. (00390a)

SERVICE PARTS

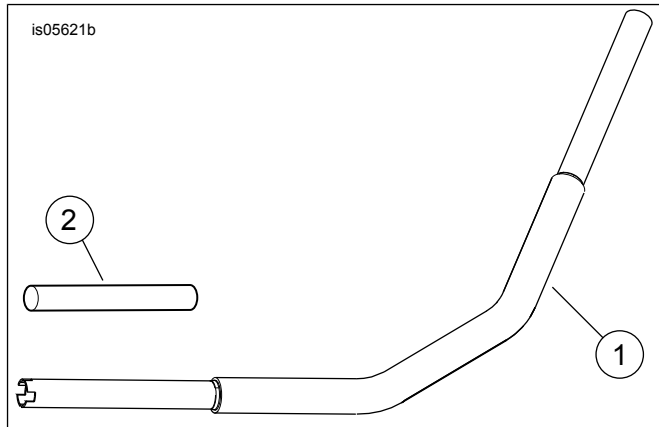

Figure 2. Service Parts: Handlebar Kit

Table 1. Service Parts

Item	Description (Quantity)	Part Number
1	Handlebar	Not Sold Separately
2	Conduit, black mesh (for non-FXDF models only)	70017-06
3	Cable tie (4) (not shown)	10181