



# INSTRUCTIONS

J05185

2013-07-15



## LIGHTED MIRROR KITS

### GENERAL

#### Kit Number

92059-07A, 92068-08A

#### Models

For model fitment information, see the P&A Retail Catalog or the Parts and Accessories section of [www.harley-davidson.com](http://www.harley-davidson.com) (English only).

#### NOTE

*This kit fits certain models equipped with stock mirrors.*

*The mirrors in this kit are not intended to replace the stock turn signals. Mirror turn signals will not function properly without the stock turn signals installed.*

### Installation Requirements

#### ⚠ WARNING

Rider and passenger safety depend upon the correct installation of this kit. Use the appropriate service manual procedures. If the procedure is not within your capabilities or you do not have the correct tools, have a Harley-Davidson dealer perform the installation. Improper installation of this kit could result in death or serious injury. (00333b)

#### NOTE

*This instruction sheet references service manual information. A service manual for your model motorcycle is required for this installation and is available from a Harley-Davidson dealer.*

#### NOTICE

**It is possible to overload the vehicle's charging system by adding too many electrical accessories. If the combined electrical accessories operating at any one time consume more electrical current than the vehicle's charging system can produce, the electrical consumption can discharge the battery and cause damage to the vehicle's electrical system. (00211d)**

### Kit Contents

See Figure 26 and Table 7.

#### NOTE

*Place a clean shop towel or a protective blanket over the equipment to avoid scratching painted surfaces when installing this kit.*

*This kit requires up to 500 mA of additional current from the electrical system.*

#### ⚠ WARNING

When installing any electrical accessory, be certain not to exceed the maximum amperage rating of the fuse or circuit breaker protecting the affected circuit being modified. Exceeding the maximum amperage can lead to electrical failures, which could result in death or serious injury. (00310a)

### REMOVAL

#### Prepare for Service

**Touring Models:** Remove left side saddlebag, left side cover and main fuse following the instructions in the appropriate service manual.

**Softail and Dyna Models:**

#### ⚠ WARNING

To prevent accidental vehicle start-up, which could cause death or serious injury, disconnect battery cables (negative (-) cable first) before proceeding. (00307a)

#### ⚠ WARNING

Disconnect negative (-) battery cable first. If positive (+) cable should contact ground with negative (-) cable connected, the resulting sparks can cause a battery explosion, which could result in death or serious injury. (00049a)

1. Remove seat according to the instructions in the service manual.
2. Disconnect negative battery cable.
3. Remove fuel tank following the instructions in the appropriate Service Manual.

**Sportster Models:** Remove left side cover and main fuse following the instructions in the appropriate service manual.

**V-Rod Models:** Remove right side cover and main fuse following the instructions in the appropriate service manual.

### Remove Existing Mirrors

#### Touring and Softail (Except FXSTD, FLSTF) Models

1. See Figure 1. Remove acorn nut (1), star washer (2) and existing mirror (3) from clutch hand control assembly. Discard star washer and mirror but save acorn nut.
2. See Figure 2. Repeat Step 1 for the front brake hand control assembly. Discard star washer and mirror but save acorn nut.



is03431

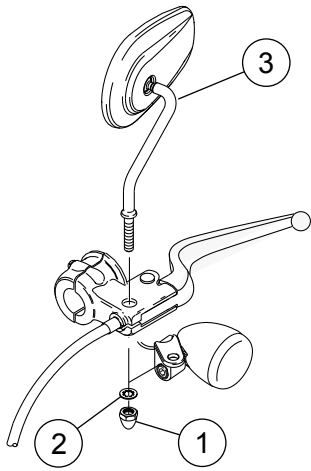

1. Acorn nut
2. Star washer
3. Mirror, left

Figure 1. Remove Left Mirror (Except Sportster)

is03432

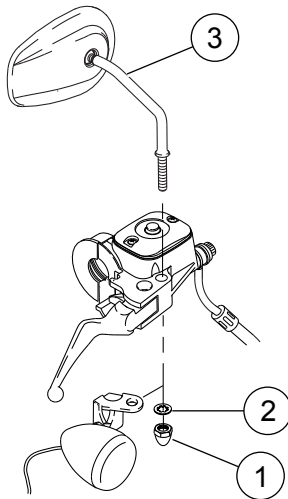

1. Acorn nut
2. Star washer
3. Mirror, right

Figure 2. Remove Right Mirror (Touring, Softail - Except FXSTD, FLSTF)

#### Dyna, FXSTD, FLSTF and VRSC Models

1. See Figure 1. Remove acorn nut (1), star washer (2) and existing mirror (3) from clutch hand control assembly. Discard star washer and mirror but save acorn nut.
2. See Figure 3. Loosen ball stud clamp (1) to remove directional lamp assembly (2). Remove retainer (3), star washer (4) and existing mirror (5) from front brake hand control assembly. Discard star washer and mirror but save remaining parts.

is03428

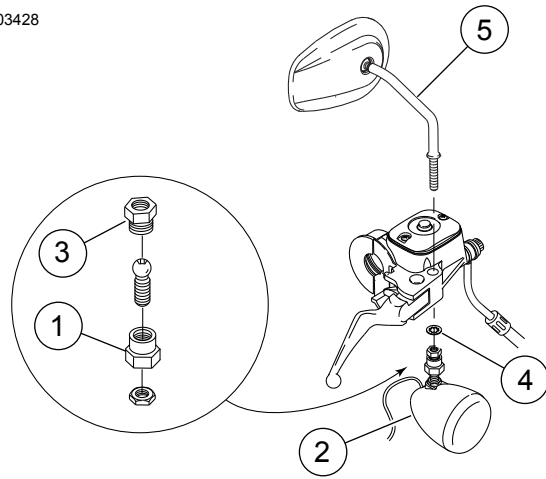

1. Ball stud clamp
2. Directional lamp assembly
3. Retainer
4. Star washer
5. Mirror, right

Figure 3. Remove Right Mirror (Dyna, FXSTD, FLSTF, VRSC)

#### Sportster Models

1. See Figure 4. Remove locknut (1), washer (2) and existing mirror (3) from clutch hand control assembly (left side). Discard washer and mirror but save locknut.
2. Repeat for brake hand control (right side).

is03414

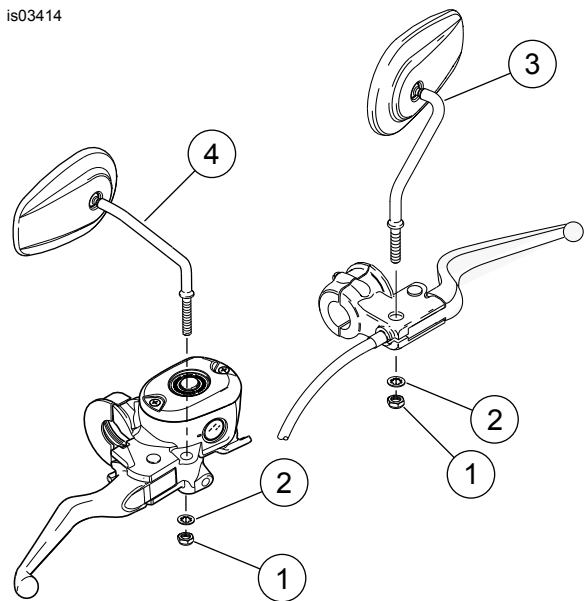

1. Locknut (2)
2. Washer (2)
3. Mirror, left
4. Mirror, right

Figure 4. Remove Mirrors (Sportster)

## INSTALLATION

### Install Lighted Mirrors

#### Touring and Softail (Except FXSTD, FLSTF, FXSTS, FLSTS) Models

1. See Figure 5. Install mirror stem (1) through clutch hand control assembly.
2. Install stock washer (2) or flat washer from kit (3) on top of hand control assembly (if needed) to stabilize mirror stem.
3. Slide mirror power lead wire (gray) through ground wire ring terminal (5) (flat side up). Install ring terminal on mirror stem.
4. Slide mirror power lead wire (gray) through wire guard (6). Install wire guard on mirror stem.
5. Install flat washer (3) from kit on mirror stem.

#### NOTE

Make sure wire exiting mirror stem is positioned in wire guard so it does not get crushed by hardware.

6. Install acorn nut (4) on mirror stem (1). Tighten to 10.8–16.3 N·m (8–12 ft-lbs). Do not over-tighten.
7. See Figure 6. Repeat Steps 1-6 for front brake hand control assembly.

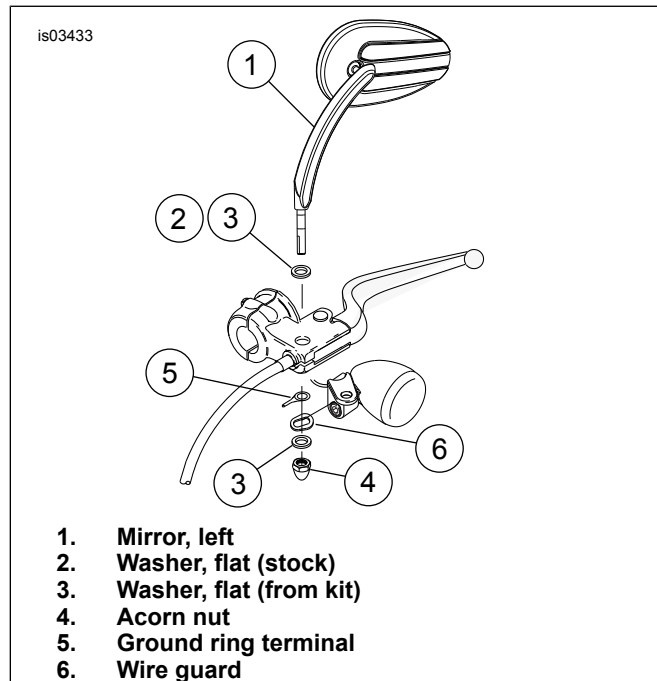

Figure 5. Install Left Lighted Mirror (Except Sportster, FXSTS, FLSTS)

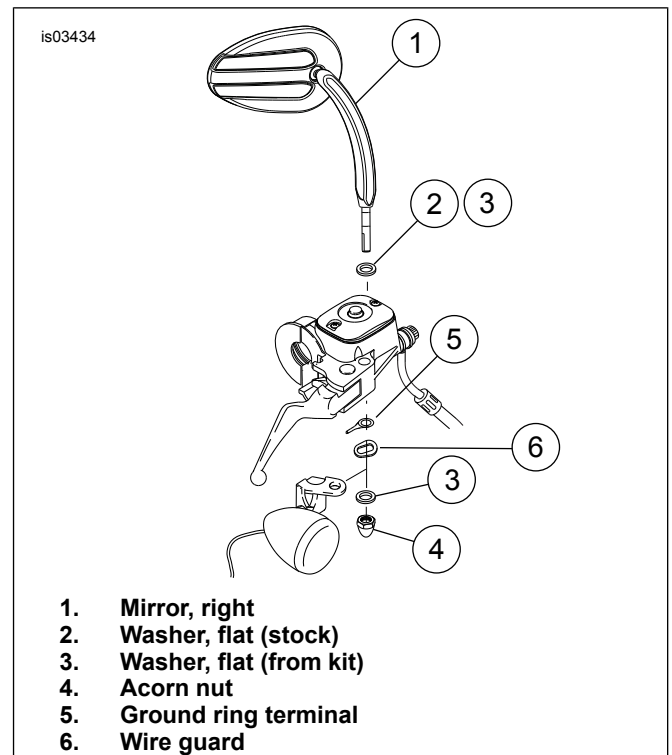

Figure 6. Install Right Lighted Mirror (Except Sportster, Dyna, FXSTD, FLSTF, FXSTS, FLSTS, VRSC)

#### Dyna, FXSTD, FLSTF and VRSC Models

1. See Figure 5. Complete Steps 1-6 for Touring and Softail to install left side lighted mirror (clutch hand control assembly).
2. See Figure 7. Install mirror stem (1) through front brake hand control assembly.
3. Install stock washer (2) on top of hand control assembly or use flat washer (3) from kit (if needed) to stabilize mirror stem.
4. Slide mirror power lead wire (gray) through ground wire ring terminal (7) (flat side up). Install ring terminal on mirror stem.
5. Slide mirror power lead wire (gray) through wire guard (8). Install wire guard on mirror stem.
6. Install flat washer (3) from kit on mirror stem (1).

#### NOTE

Make sure wire exiting mirror stem is positioned in wire guard so it does not get crushed by hardware.

7. Install retainer (4) on mirror stem (1). Tighten ball stud clamp (5) to install directional lamp assembly (6).

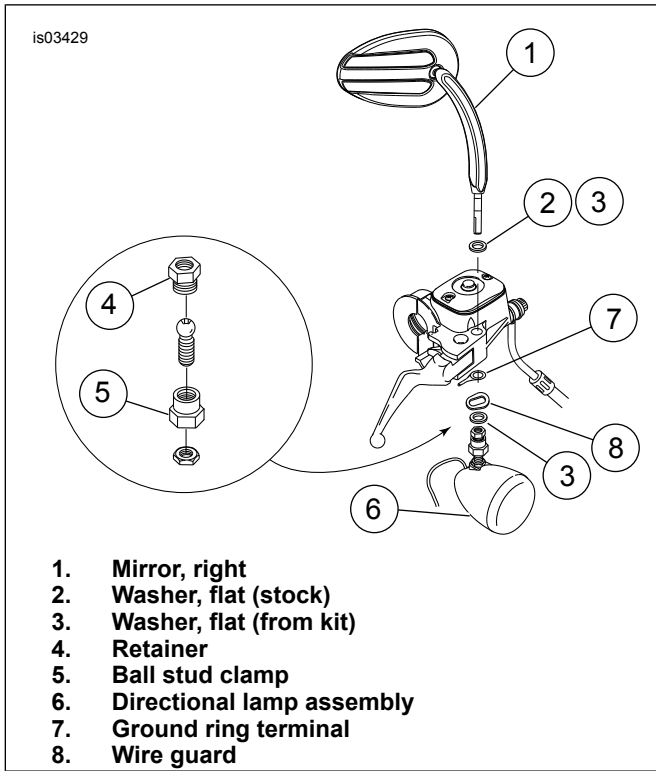

**Figure 7. Install Right Lighted Mirror (Dyna, FXSTD, FLSTF, VRSC)**

**FXSTS and FLSTS Models**

1. See Figure 8. Install mirror stem (1) through clutch hand control assembly.
2. Install stock washer (2) on top of hand control assembly or use flat washer (3) from kit (if needed) to stabilize mirror stem.
3. Slide mirror power lead wire (gray) through ground wire ring terminal (6) (flat side up). Install ring terminal on mirror stem.
4. See Figure 8. Slide mirror power lead wire through flat washer (3) from kit, then install washer on mirror stem.
5. Slide mirror power through locknut (4) from kit. Install locknut on mirror stem (1). Tighten to 10.8–16.3 N·m (8–12 ft-lbs). Do not over-tighten.
6. See Figure 8. Repeat Steps 1-5 for the front brake hand control assembly.

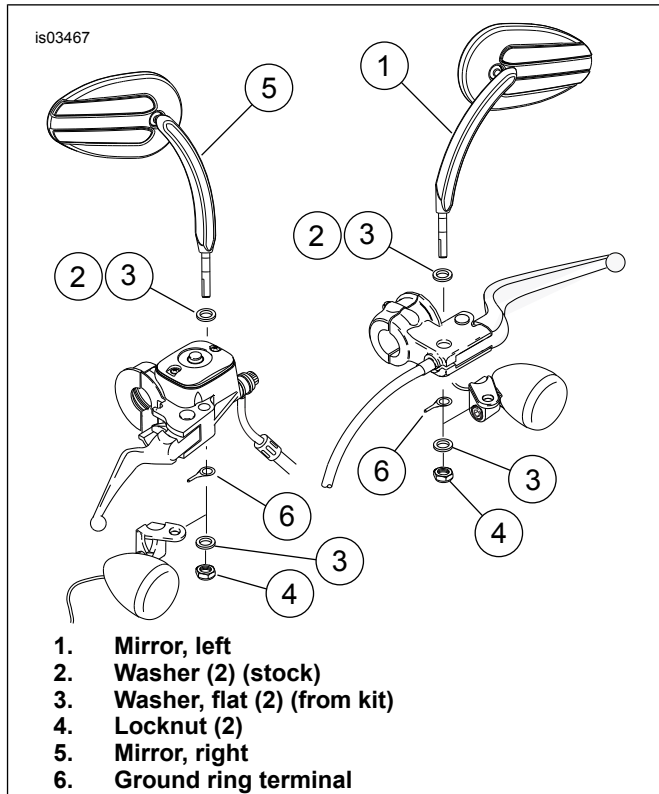

**Figure 8. Install Lighted Mirrors (FXSTS, FLSTS)**

**Sportster Models**

1. See Figure 9. Install mirror stem (1) through clutch hand control assembly.
2. Install stock washer (2) on top of hand control assembly or use flat washer (3) from kit (if needed) to stabilize mirror stem.
3. Slide mirror power lead wire (gray) through ground wire ring terminal (6) (flat side up). Install ring terminal on mirror stem.
4. Slide mirror power lead wire through flat washer (3) from kit. Install washer on mirror stem.
5. Slide mirror power lead through locknut (4) from kit. Install locknut on mirror stem (1). Tighten to 10.8–16.3 N·m (8–12 ft-lbs). Do not over-tighten.
6. See Figure 9. Repeat Steps 1-5 for the front brake hand control assembly.

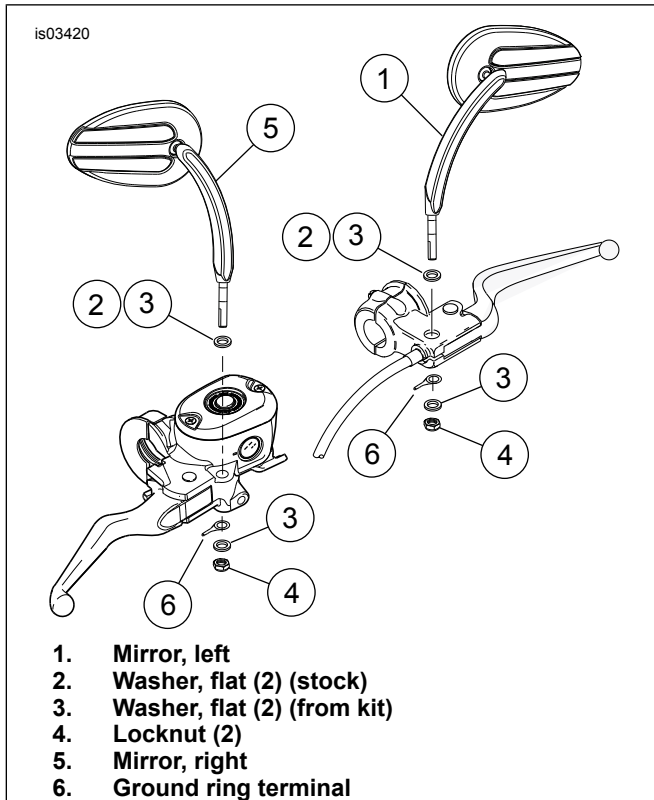

Figure 9. Install Lighted Mirrors (Sportster)

Table 1. Turn Signal Connectors

Model	Multilock Connector
Touring models:	
• 2013 and earlier FLHR/C/S	6-way
• 2014 and later FLHR/C	6-way and 4-way
• 2005 and earlier FLHT/C/U	6-way
• 2006 and later FLHT/C/U, FLHX	4-way
• 2002 and earlier FLTR	6-way
• 2003 and later FLTR	3-way
All Softail models	6-way
Dyna models:	
• 2005 and earlier models	6-way
• 2006 and later FLHR/C models	3-way
All Sportster models	6-way
All VRSC models	6-way

### Install Y-Harness - 2013 and Earlier FLHR/C/S Models

1. Remove headlamp assembly following the instructions in the appropriate service manual.
2. See Figure 10 and Table 1. Locate and separate front turn signal connector inside nacelle. Note wire color and cavity locations.

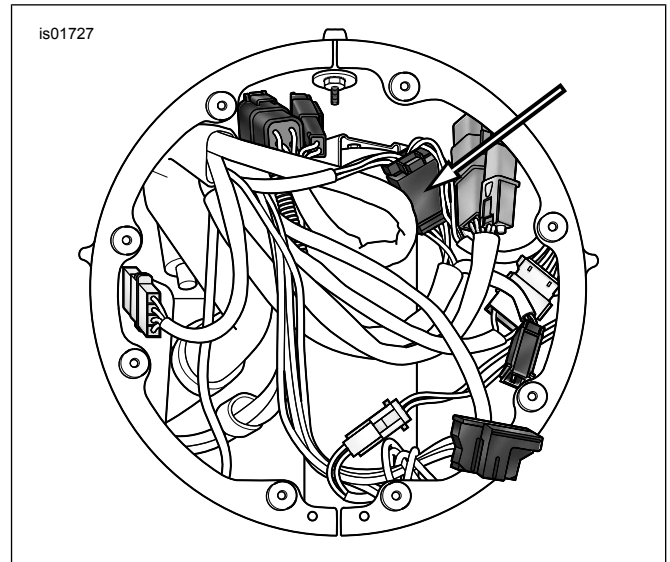

Figure 10. Front Turn Signal Connector (FLHR/C/S)

Table 2. Wire Color and Cavity Locations - Earlier Models

Left and Right Turn Signals			
<b>Right Turn Signal</b>			
Cavity	1	2	3
6-Place Connector	Blk	Brn	Blue
Y-Harness	Blk	Red	Blue
<b>Left Turn Signal</b>			
Cavity	4	5	6
6-Place Connector	Blue	Vio	Blk
Y-Harness	Blue	Red	Blk

Table 3. Wire Color and Cavity Locations (2014 and Later Sportster Models)

Left and Right Turn Signals			
<b>Right Turn Signal</b>			
Cavity	1	2	3
6-Place Connector	Blk	BE/O	Blue
Y-Harness	Blk	Red	Blue
<b>Left Turn Signal</b>			
Cavity	4	5	6
6-Place Connector	Blue	BE/PK	Blk
Y-Harness	Blue	Red	Blk

Table 4. Wire Color and Cavity Locations (2011 and Later Softail Models)

Left and Right Turn Signals			
<b>Right Turn Signal</b>			
Cavity	1	2	3
6-Place Connector	Blk	BE/O	Blue
Y-Harness	Blk	Red	Blue
<b>Left Turn Signal</b>			
Cavity	4	5	6
6-Place Connector	Blue	BE/PK	Blk
Y-Harness	Blue	Red	Blk

3. See Figure 26 and Table 2. Select 6-place multilock connectors (12, 13) and two Y-harness assemblies (5). Align both Y-harness assemblies together, matching pin terminated wire ends and socket terminated wire ends.
4. Coat terminals on Y-harness with dielectric grease (18).

5. See Figure 11. Install connectors on ends of combined Y-harness assemblies. Note wire color and cavity locations. Refer to MULTILOCK ELECTRICAL CONNECTORS in service manual.
6. Insert combined Y-harness assembly between the two separated front turn signal connectors on vehicle.

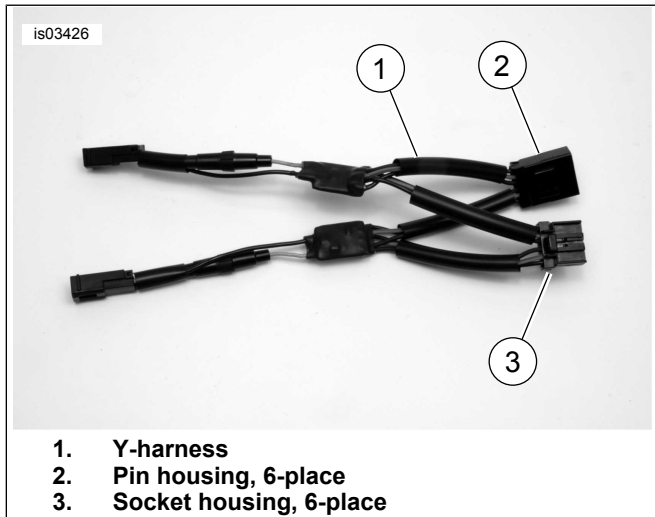

Figure 11. Y-Harness Assembly (6-Place Multilock)

### Install Y-Harness - 2014 and Later FLHR/C Models

1. See the service manual. Remove headlamp assembly.
2. See Figure 12. Locate and disconnect front turn signal connectors in the left side caddy. Note wire color and cavity locations.

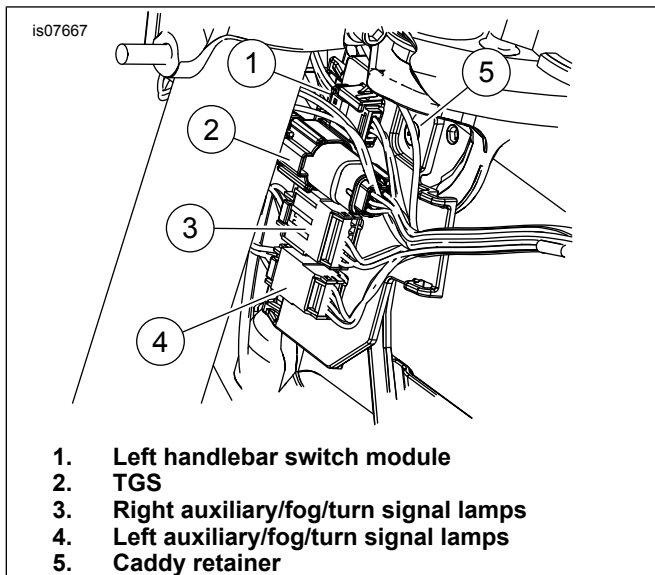

Figure 12. Left Side Connectors

3. Assemble one Y-harness with 4-way connectors
  - a. See Figure 26 and Table 5. Select 4-way multilock pin housing (10), socket housing (11), Y-harness assembly (5) and jumper wire (14).

- b. Coat terminals on Y-harness with dielectric grease (18).
- c. See Figure 16. Install connectors on ends of combined Y-harness assemblies. Note wire color and cavity locations. Refer to MULTILOCK ELECTRICAL CONNECTORS in service manual. The jumper wire will connect the two connectors at cavity 4.

4. Assemble one Y-harness with 6-way connectors
  - a. See Figure 26 and Table 5. Select 6-way multilock pin housing (12), socket housing (13), Y-harness assembly (5) and jumper wire (14).
  - b. Coat terminals on Y-harness with dielectric grease (18).
  - c. See Figure 16. Install connectors on ends of combined Y-harness assemblies. Note wire color and cavity locations. Refer to MULTILOCK ELECTRICAL CONNECTORS in service manual. The jumper wire will connect the two connectors at cavity 4.
5. Install the assembled Y-harnesses between the two disconnected front turn signal connectors.

Table 5. Wire Color and Cavity Locations - 2014 and Later FLHR/C

Left and Right Turn Signal Connectors						
Right Turn Signal						
Cavity	1	2	3	4	5	6
Main Harness 6-Place Connector	BK	BE/O	BE	BE/BK	N/A	N/A
Y-Harness 6-Way Connector	BK	R	BE	GY	N/A	N/A
Left Turn Signal						
Cavity	1	2	3	4	-	-
Main Harness 4-Way Connector	BK	BE/PK	BE	BE/BK	-	-
Y-Harness 4-Way Connector	BK	R	BE	GY	-	-

### Install Y-Harness - Other Touring Models

#### 6-Place Multilock Connectors:

1. Remove outer fairing following the instructions in the appropriate service manual.
2. See Figure 13 and Table 1. Locate and separate front turn signal connector inside inner fairing - left fairing support brace. Note wire color and cavity locations.

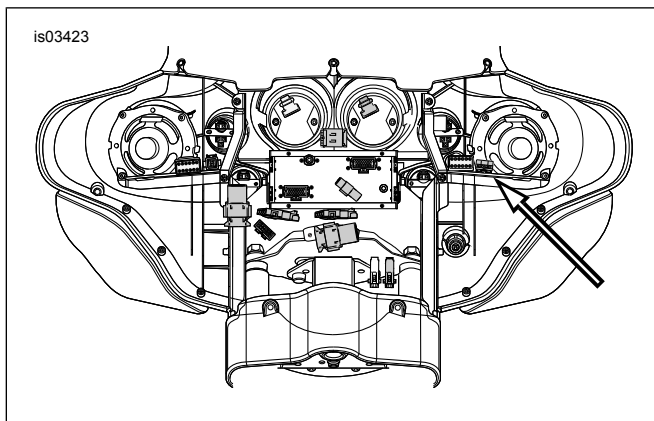
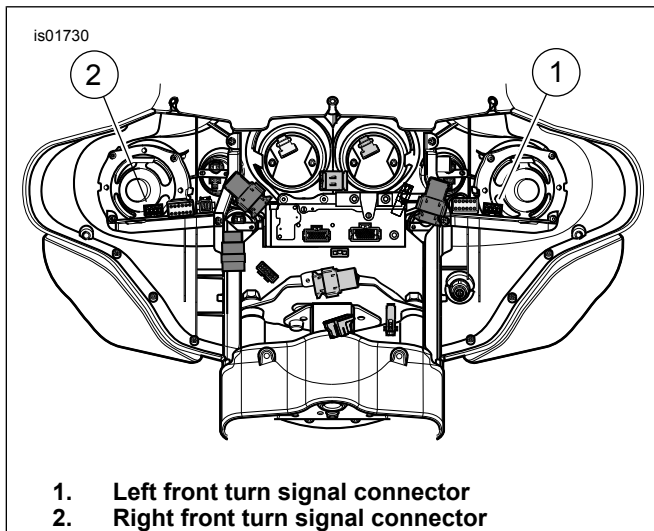

**Figure 13. Front Turn Signal Connector (2005 and Earlier FLHT/C/U)**

3. See Figure 26 and Table 2. Select 6-place multilock connectors (12, 13) and two Y-harness assemblies (5). Align both Y-harness assemblies together, matching pin terminated wire ends and socket terminated wire ends.
4. Coat terminals on Y-harness with dielectric grease (18).
5. See Figure 11. Install connectors on ends of combined Y-harness assemblies. Note wire color and cavity locations. Refer to MULTILOCK ELECTRICAL CONNECTORS in service manual.
6. Insert combined Y-harness assembly between the two separated front turn signal connectors.

**3- and 4-Place Multilock Connectors:**

1. Remove outer fairing following the instructions in the appropriate service manual.
2. See Figure 14 and Table 6. Locate and separate front turn signal connectors inside inner fairing - left and right fairing support brace. Note wire color and cavity locations.



**Figure 14. Front Turn Signal Connectors (FLTR Shown)**

3. See Figure 26. Select appropriate connectors (3- or 4-place) and two Y-harness assemblies (5).

4. Coat terminals on Y-harness with dielectric grease (18).
5. See Figure 15 and Figure 16. Install appropriate connectors on ends of Y-harness assemblies. See Table 6. Note wire color and cavity locations. Refer to MULTILOCK ELECTRICAL CONNECTORS in service manual.
6. See Figure 16. For models with 4-place multilock connectors, install ends of jumper wire assembly (2) (Figure 26, Item 14) into open cavities in Y-harness connectors.
7. Insert Y-harness assemblies with connectors between the two separated front turn signal connectors on vehicle.

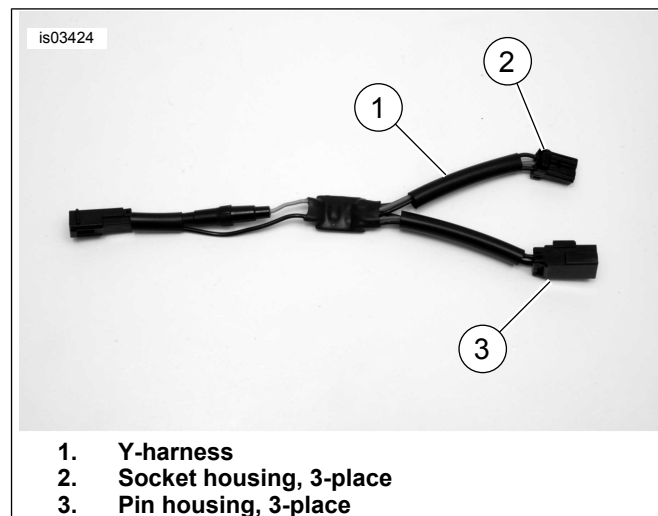

**Figure 15. Y-Harness Assembly (3-Place Multilock)**

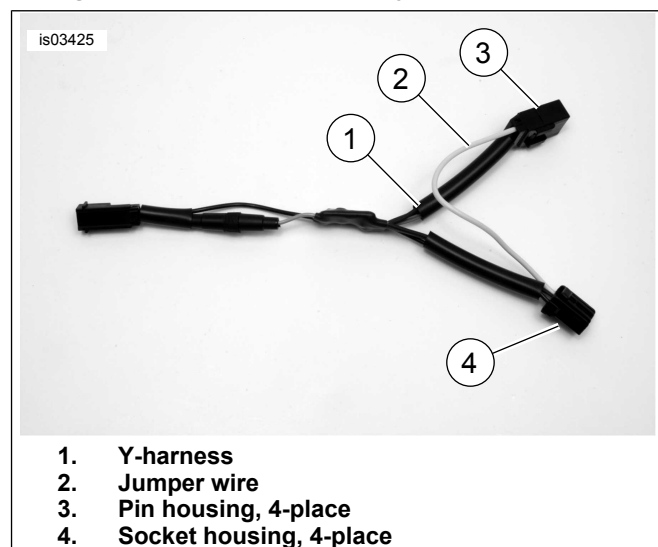

**Figure 16. Y-Harness Assembly (4-Place Multilock)**

**Table 6. Turn Signal Connections (3- and 4-Place)**

Left Turn Signal	Right Turn Signal
Violet to Red	Brown to Red
Blue to Blue	Blue to Blue
Black to Black	Black to Black
Gray/Black to Gray/Black 4-Place Only	Gray/Black to Gray/Black 4-Place Only

## Install Y-Harness - 2010 and Earlier Softail Models

### 2010 and Earlier Models:

1. See Figure 17 and Table 1. Locate and separate front turn signal connector under fuel tank on right side. Note wire color and cavity locations.
2. See Figure 26 and Table 2. Select 6-place multilock connectors (12, 13) and two Y-harness assemblies (5). Align both Y-harness assemblies together, matching pin terminated wire ends and socket terminated wire ends.
3. Coat terminals on Y-harness with dielectric grease (18).
4. See Figure 11. Install connectors on ends of combined Y-harness assemblies. Refer to Table 2 for wire colors and cavity locations. Refer to MULTILOCK ELECTRICAL CONNECTORS in service manual.
5. Insert combined Y-harness assembly between the two separated front turn signal connectors on vehicle.

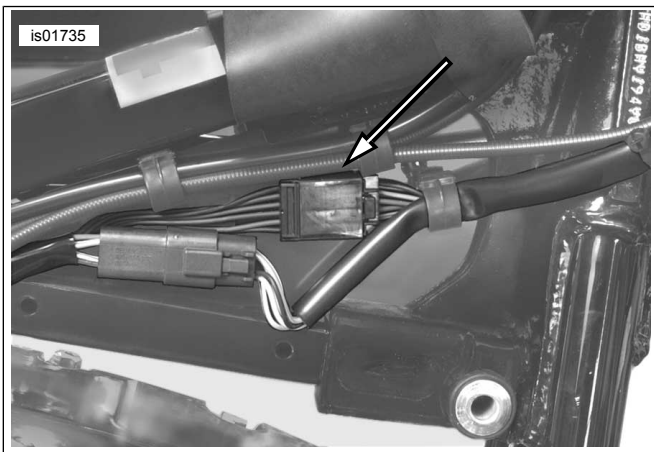

**Figure 17. Softail Front Turn Signal Connector**

### 2011 and Later FLSTC, FLSTN, FXST and FLSTSB Models:

1. See Figure 18 and Table 1. Locate and separate front turn signal connector under fuel tank on right side. Note wire color and cavity locations.
2. See Figure 26 and Table 4. Select 6-place multilock connectors (12, 13) and two Y-harness assemblies (5). Align both Y-harness assemblies together, matching pin terminated wire ends and socket terminated wire ends.
3. Coat terminals on Y-harness with dielectric grease (18).
4. See Figure 11. Install connectors on ends of combined Y-harness assemblies. Refer to Table 4 for wire colors and cavity locations. Refer to MULTILOCK ELECTRICAL CONNECTORS in service manual.
5. Insert combined Y-harness assembly between the two separated front turn signal connectors on vehicle.

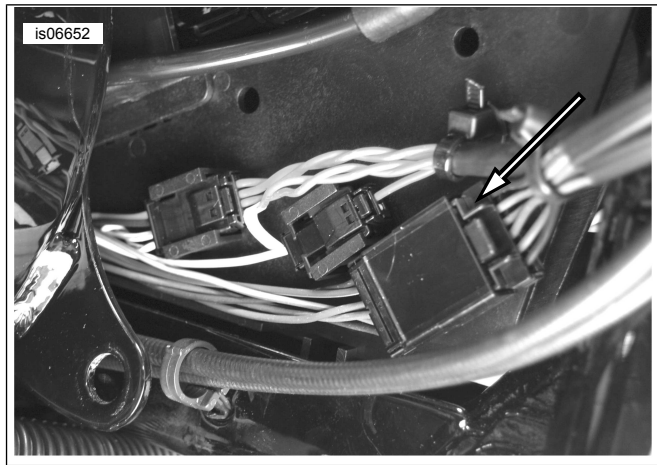

**Figure 18. Softail Front Turn Signal Connector (2011 and later FLSTC, FLSTN, FXST, and FLSTSB)**

### 2011 and Later FLSTF and FLSTFB Models:

1. See Figure 19 and Table 1. Locate the open connector under fuel tank on right side. Note wire color and cavity locations.
2. See Figure 26 and Table 4. Select 6-place multilock connectors (12, 13) and two Y-harness assemblies (5). Align both Y-harness assemblies together, matching pin terminated wire ends and socket terminated wire ends.
3. Coat terminals on Y-harness with dielectric grease (18).
4. See Figure 11. Install connectors on ends of combined Y-harness assemblies. Refer to Table 4 for wire colors and cavity locations. Refer to MULTILOCK ELECTRICAL CONNECTORS in service manual.
5. Insert the socket connector of the combined Y-harness assembly into the open connector on vehicle.
6. Secure the pin connector of the Y-harness assembly to the harness wiring using a cable strap (connector remains open).

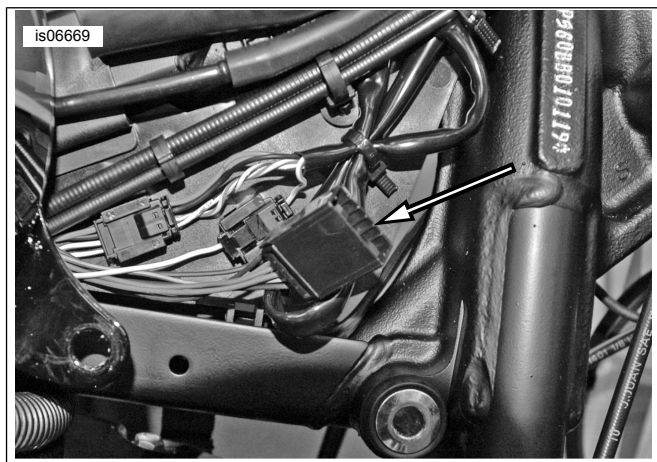

**Figure 19. Softail Open Connector (2011 and later FLSTF, FLSTFB)**



## Install Y-Harness - Dyna Models

### 2005 and Earlier Models:

1. See Figure 20 and Figure 21. Remove plug on right side of top frame tube. At service loop, remove cable strap and push wire harness into top frame tube. Pull front turn signal connector out from hole on right side of tube.
2. Separate front turn signal connectors. Note wire color and cavity locations.
3. See Figure 26 and Table 2. Select 6-place multilock connectors (12, 13) and two Y-harness assemblies (5). Align both Y-harness assemblies together, matching pin terminated wire ends and socket terminated wire ends.
4. Coat terminals on Y-harness with dielectric grease (18).
5. See Figure 11. Install connectors on ends of combined Y-harness assemblies. Note wire color and cavity locations. Refer to MULTILOCK ELECTRICAL CONNECTORS in service manual.
6. Insert combined Y-harness assembly between the two separated front turn signal connectors on vehicle.

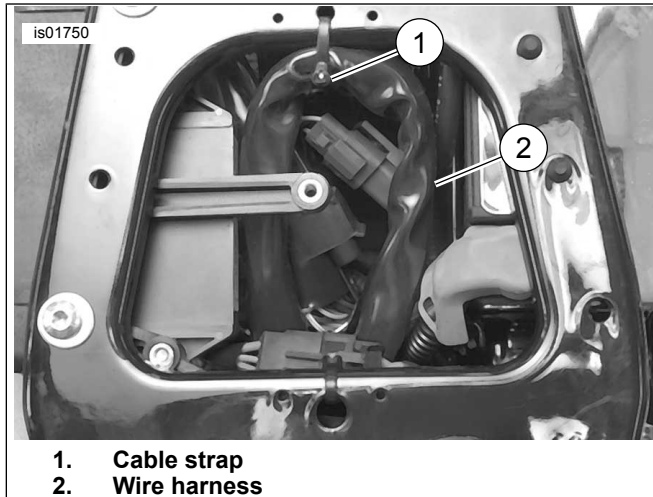

Figure 20. Dyna Service Loop (2005 and Earlier)

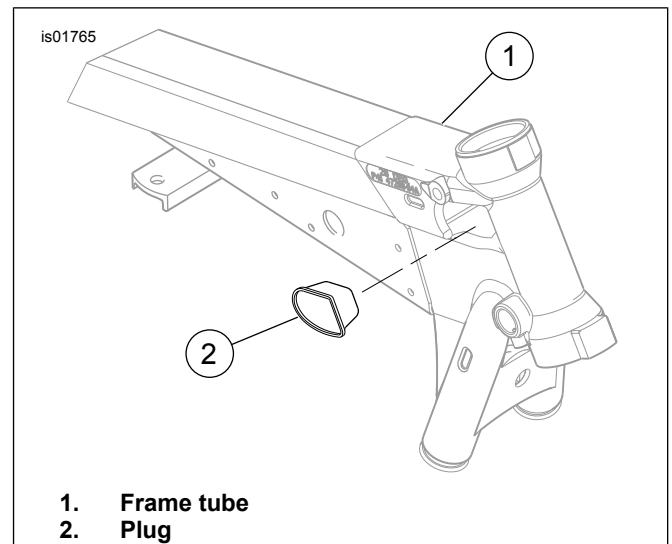

Figure 21. Dyna Top Frame Tube (2005 and Earlier)

### 2006 and Later Models:

1. See Figure 22. Remove cover under top frame tube, then pull front turn signal connectors (3-place multilock) out from opening under tube.
2. Separate front turn signal connectors. Note wire color and cavity locations.
3. See Figure 26. Select 3-place multilock connectors (8, 9) and two Y-harness assemblies (5).
4. Coat terminals on Y-harness with dielectric grease (18).
5. See Figure 15. Install connectors on ends of Y-harness assemblies. See Table 6. Note wire color and cavity locations. Refer to MULTILOCK ELECTRICAL CONNECTORS in service manual.
6. Insert Y-harness assemblies with connectors between the two separated front turn signal connectors on vehicle.

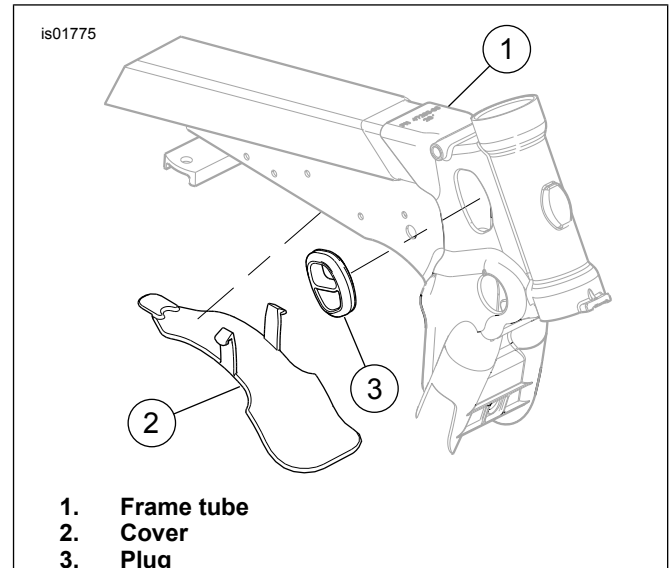
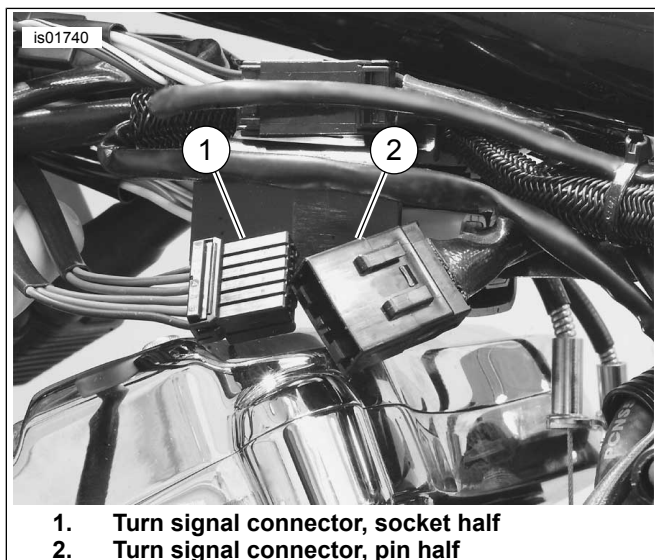

Figure 22. Dyna Top Frame Tube (2006 and Later)

## Install Y-Harness - Sportster Models

1. See Figure 23. Locate and separate front turn signal connector (6-place multilock) under fuel tank. Note wire color and cavity locations.



1. Turn signal connector, socket half  
2. Turn signal connector, pin half

Figure 23. Sportster Front Turn Signal Connector

2. See Figure 26 and Table 2 or Table 3. Select 6-place multilock connectors (12, 13) and two Y-harness assemblies (5). Align both Y-harness assemblies together, matching pin terminated wire ends and socket terminated wire ends.
3. Coat terminals on Y-harness with dielectric grease (18).
4. See Figure 11. Install connectors on ends of combined Y-harness assemblies. Note wire color and cavity locations. Refer to MULTILOCK ELECTRICAL CONNECTORS in service manual.
5. Insert combined Y-harness assembly between the two separated front turn signal connectors on vehicle.

## Install Y-Harness - V-Rod Models

1. **VRSCR Models:** See Figure 24. Remove left side cover following the instructions in the appropriate service manual. **2003 and Earlier VRSC Models:** See Figure 25. Remove instrument cluster following the instructions in the appropriate service manual. **2004 and Later VRSC Models:** Remove left side cover following the instructions in the appropriate service manual.
2. Locate and separate front turn signal connector (6-place multilock). Note wire color and cavity locations.
3. See Figure 26 and Table 2. Select 6-place multilock connectors (12, 13) and two Y-harness assemblies (5). Align both Y-harness assemblies together, matching pin terminated wire ends and socket terminated wire ends.
4. Coat terminals on Y-harness with dielectric grease (18).

5. See Figure 11. Install connectors on ends of combined Y-harness assemblies. Note wire color and cavity locations. Refer to MULTILOCK ELECTRICAL CONNECTORS in service manual.
6. Insert combined Y-harness assembly between the two separated front turn signal connectors on vehicle.

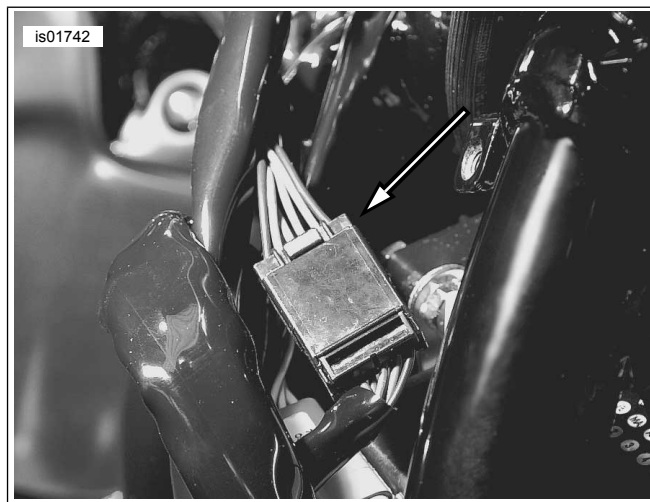
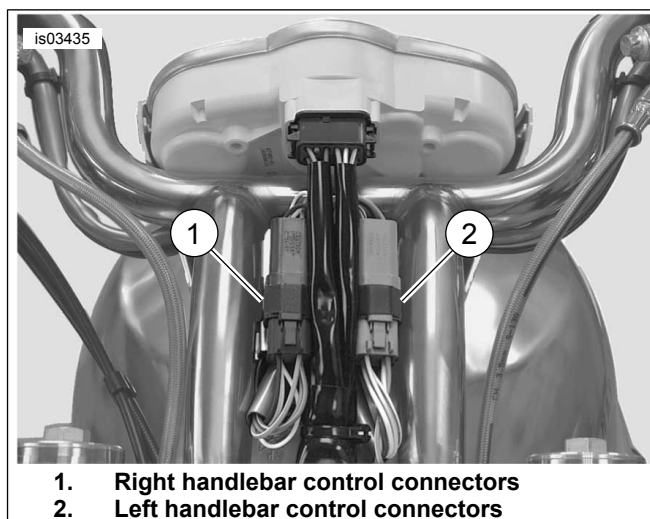

Figure 24. V-Rod Front Turn Signal Connector (2004 and Later)



1. Right handlebar control connectors  
2. Left handlebar control connectors

Figure 25. V-Rod Handlebar Control Connectors (2003 and Earlier)

## Connect Mirrors to Y-Harnesses (All Models)

1. Determine path for routing wires from mirror to Y-harnesses from kit plugged in between front turn signal connectors on vehicle. Wires will travel along handlebars towards center of the motorcycle.
2. Cut mirror power and ground wire leads to optimal length for reaching Y-harnesses.
3. See Figure 26. Slide conduit (6) up mirror power and ground wire leads.
4. Terminate ends of mirror and ground wires with socket terminals (4) from kit using crimping tool. Follow the instructions in the appropriate service manual.
5. Coat terminals with dielectric grease (18).

6. Install 2-place socket connectors on each pair of terminated mirror wire leads following the instructions in the appropriate service manual. Note which connectors are for left and right mirrors.
7. Plug 2-place socket connectors from mirror wire leads into appropriate left and right open 2-place pin connectors in Y-harnesses installed on vehicle.
8. Install cable straps (17) around Y-harness wires and to secure mirror wire conduit to handlebars.

## Final Assembly

### Touring Models

1. **FLHR/C/S Models:** Install headlamp assembly following the instructions in the appropriate service manual. **Other Touring Models:** Install outer fairing following the instructions in the appropriate service manual.
2. Install main fuse, left side cover and left side saddlebag following the instructions in the appropriate service manual.

### Softail and Dyna Models

1. Install fuel tank following the instructions in the appropriate service manual.

#### ⚠ WARNING

**Connect positive (+) battery cable first. If positive (+) cable should contact ground with negative (-) cable connected, the resulting sparks can cause a battery explosion, which could result in death or serious injury. (00068a)**

2. Connect both battery cables, positive battery cable first.

#### ⚠ WARNING

**After installing seat, pull upward on seat to be sure it is locked in position. While riding, a loose seat can shift causing loss of control, which could result in death or serious injury. (00070b)**

3. Install seat following the instructions in the appropriate service manual.

### Sportster Models

1. Install fuel tank following the instructions in the appropriate service manual.
2. Install seat following the instructions in the appropriate service manual.

#### ⚠ WARNING

**After installing seat, pull upward on seat to be sure it is locked in position. While riding, a loose seat can shift causing loss of control, which could result in death or serious injury. (00070b)**

3. Install main fuse and left side cover following the instructions in the appropriate service manual.

### V-Rod Models

1. **2003 and Earlier:** Install instrument cluster following the instructions in the appropriate service manual. **2004 and Later:** Install left side cover following the instructions in the appropriate service manual.
2. Install main fuse and right side cover following the instructions in the appropriate service manual.

## SERVICE PARTS

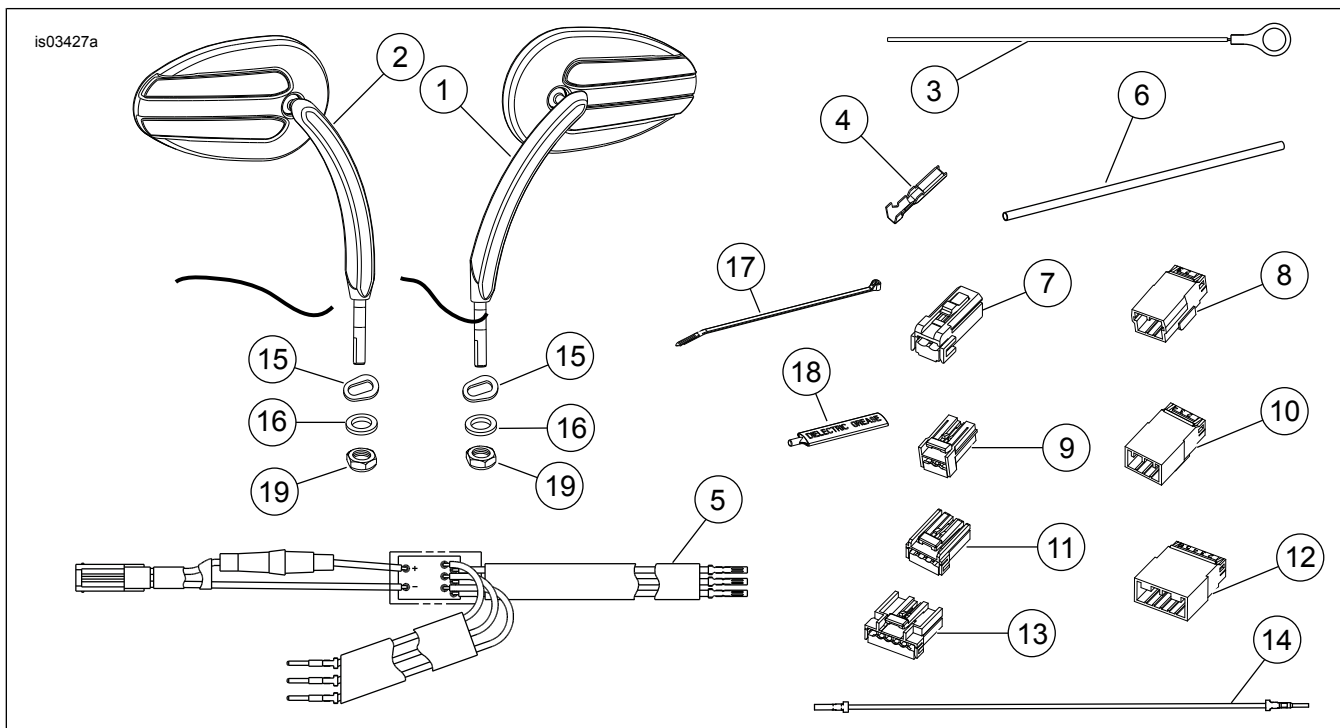

Figure 26. Service Parts: Lighted Mirrors

Table 7. Service Parts: Lighted Mirrors

Item	Description (Quantity)	Part Number
1	Lighted mirror, left (with gray lead wire), chrome	92055-07
	Lighted mirror, left (with gray lead wire), black	92138-08
2	Lighted mirror, right (with gray lead wire), chrome	92056-07
	Lighted mirror, right (with gray lead wire), black	92077-08
3	Ground ring terminal (2)	Not Sold Separately
4	Terminal, socket (6)	72560-07
5	Y-Harness assembly (2) (includes fuse holder and fuse)	92060-07A
	Fuse, 1 amp glass (2) (not shown)	56880-06
	Fuse, 2 amp blade (2) (not shown)	54305-98
6	Conduit, black (2)	Not Sold Separately
7	Socket housing, 2-place (2)	73152-96BK
8	Pin housing, 3-place (2)	73103-96BK
9	Socket housing, 3-place (2)	73153-96BK
10	Pin housing, 4-place (2)	73104-96BK
11	Socket housing, 4-place (2)	73154-96BK
12	Pin housing, 6-place	73106-96BK
13	Socket housing, 6-place	73156-96BK
14	Jumper wire assembly (2)	56913-06
15	Wire guard (2)	72561-07
16	Washer, flat (4)	6771A
17	Cable strap (10)	10006
18	Dielectric grease, 4-6 gram packet	Not Sold Separately
19	Locknut, nylon insert 5/16-24 (2) - Sportster, FXSTS, FLSTS models only	7727